



Hollister-Whitney Elevator Corporation

#1 Hollister-Whitney Parkway
Quincy, IL 62305
Phone: 217-222-0466

Fax: 217-222-0493
e-mail: info@hollisterwhitney.com
www.hollisterwhitney.com

DRUM BRAKE ADJUSTMENTS

For Drum Brakes equipped with Dual Micro-Switches, see also E-Document E-160

At

<http://www.hollisterwhitney.com/#tech-support>

IMPORTANT: READ ENTIRE INSTRUCTIONS BEFORE ATTEMPTING ADJUSTMENT!!!
SHOCK WARNING: ACTIVE ELECTRIC CIRCUITS!!

- 1.) Energize and de-energize solenoid to determine that each plunger moves an equal distance, meeting in center with equal amounts protruding from housing. Adjust spring adjustment screws to assure this centering.
- 2.) Make sure there is approximately 1/32" between each centering screw and the housing when the solenoid is energized (i.e. plungers make contact). **IMPORTANT:** DO NOT use centering screws as stops to limit the travel of either plunger.
- 3.) Turn heel and toe adjustment bolt, with solenoid energized, to adjust top and bottom of shoes to get equal drum clearance. Clearance between shoes and drum may be increased or decreased by adjusting plunger eye bolts (by rotating plungers) equally on each plunger. Final drum clearance should be 0.005". Re-adjust centering screws so they are spaced properly to the housing as described in 2.) above.
- 4.) With the heel and toe adjusting plate screws partially tightened, lightly tap side of adjusting plate to correct twisting motion created when shoe contacts drum face. Re-adjust heel and toe main bolt for clearance between shoe and drum.
- 5.) Run car to determine overall Brake performance. Spring tension may have to be varied to obtain harder or softer stops and can only be determined by specific job conditions.

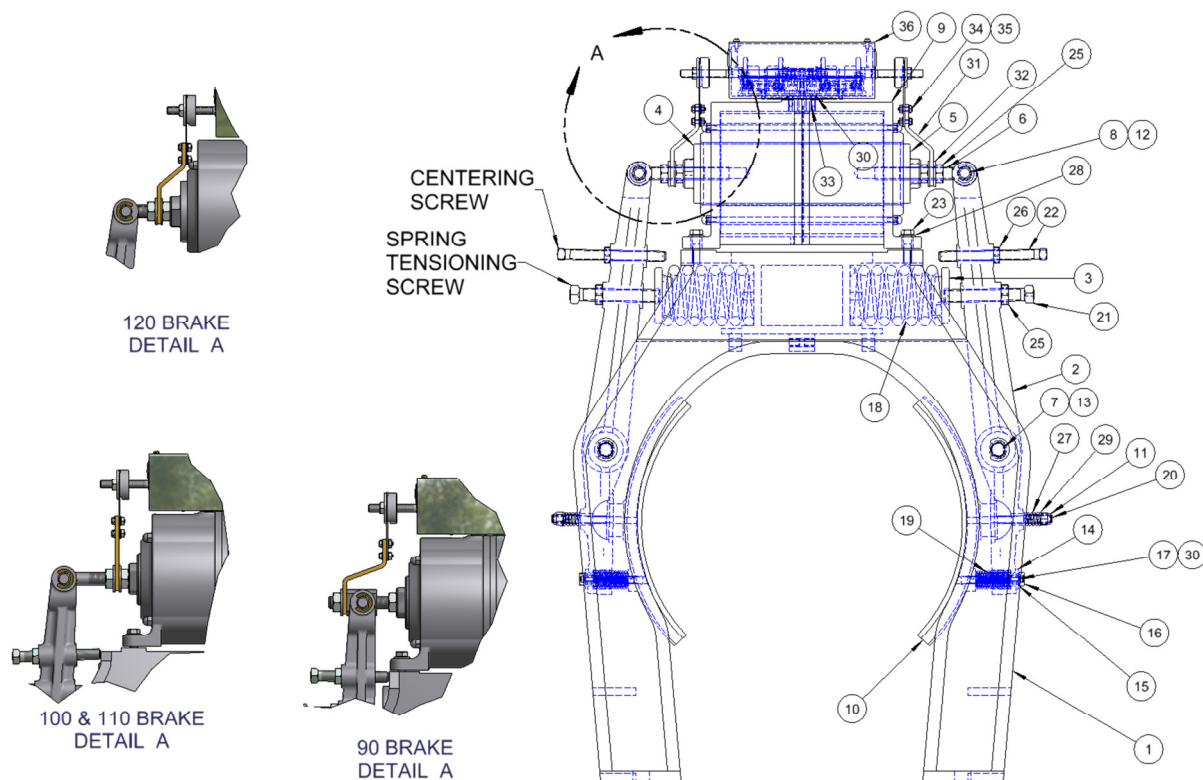

	#90 (10" DRUM)		#100 (12" DRUM)		#110 (14" DRUM)		#120 (16" DRUM)			
ITEM	QTY	PART NUMBER	QTY	PART NUMBER	QTY	PART NUMBER	QTY	PART NUMBER	DESCRIPTION	
1	1	90-001	1	100-001	1	110-001	1	120-001	BRAKE HOUSING	
2	2	90-003A	2	90-003A	2	110-003A	2	120-003A	BRAKE LEVER w/BUSHINGS	
3	2	90-005	2	90-005	2	90-005	2	90-005	CAP - BRAKE SPRING	
4	1	90-006	1	90-006	1	90-006	1	120-006	PLUNGER - BRAKE	
5	1	90-007	1	90-007	1	90-007	1	120-007	PLUNGER WITH PLUNGER RING	
6	2	90-064	2	100-008	2	100-008	2	90-008	PLUNGER EYEBOLT	
7	2	90-012	2	100-012	2	110-012	2	120-012	PIN - BRAKE LEVER	
8	2	90-013	2	90-013	2	90-013	2	90-013	PIN - 0.625" DIA.	
9	1	90-028	1	90-028	1	90-028	1	120-028	BRAKE SOLENOID ASSEMBLY	
	9A	1	90-035	1	90-035	1	90-035	1	120-035	115V COIL
	9B	1	90-022	1	90-022	1	90-022	1	120-022	230V COIL
10	2	90-029A	2	100-029A	2	110-029A	2	120-029A	BRAKE SHOE ASSEMBLY	
11	2	90-030	2	90-030	2	90-030	2	90-030	3/8 NYLON LOCK NUT	
12	3	90-032	3	90-032	3	90-032	3	90-032	E-CLIP, #5133-62	
13	4	90-033	4	90-033	4	90-033	4	90-033	E-CLIP, #X5133-74	
14	2	90-036	2	90-036	2	90-036	2	90-036	PLATE - HEEL & TOE ADJUSTMENT	
15	2	90-045	2	90-045	2	90-045	2	90-045	BUSHING	
16	2	90-038	2	90-038	2	110-038	2	110-038	BOLT - HEEL AND TOE ADJUSTMENT	
17	4	90-039	4	90-039	4	90-039	4	90-039	WASHER	
18	2	400-032	2	400-032	2	400-032	2	400-034	SPRING - LEVER	
19	2	400-039	2	400-039	2	400-039	2	400-019	SPRING - SHOE	
20	2	500-023	2	500-023	2	500-023	2	500-023	STUD	
21	2	5/8 - 11 UNC x 4	2	5/8 - 11 UNC x 4.5	2	5/8 - 11 UNC x 5	2	5/8 - 11 UNC x 4	SCREW, SQ HD SET	
22	2	1/2 - 13 UNC x 3.5	2	1/2 - 13 UNC x 3.5	2	1/2 - 13 UNC x 4	2	1/2 - 13 UNC x 5	SCREW, SQ HD SET	
23	4	3/8 - 16 UNC x 1.25	4	3/8 - 16 UNC x 1.25	4	3/8 - 16 UNC x 1.25	4	3/8 x 1.5" UNC	HEX HEAD CAP SCREW	
24	4	#10-32 x 0.5	4	#10-32 x 0.5	4	#10-32 x 0.5	4	#10-32 x 0.5	SCREW, FILLISTER HEAD	
25	6	5/8 - 11 UNC	6	5/8 - 11 UNC	6	5/8 - 11 UNC	6	5/8 - 11 UNC	HEX JAM NUT	
26	2	1/2 - 13 UNC	2	1/2 - 13 UNC	2	1/2 - 13 UNC	2	1/2 - 13 UNC	HEX JAM NUT	
27	2	400-070	2	400-070	2	400-070	2	400-070	SPRING - PIVOT	
28	4	3/8 WASHER	4	3/8 WASHER	4	3/8 WASHER	4	3/8 WASHER	STANDARD WASHER	
29	4	5/16 WASHER	4	5/16 WASHER	4	5/16 WASHER	4	5/16 WASHER	STANDARD WASHER	
30	6	#10 WASHER	6	#10 WASHER	6	#10 WASHER	6	#10 WASHER	LOCK WASHER	
31	2	90-085	2	110-085	2	110-085	2	120-085	EXTENSION - BRAKE ARM	
32	2	5/8 WASHER	4	5/8 WASHER	4	5/8 WASHER	4	5/8 WASHER	STANDARD WASHER	
33	2	#10-24 UNC x 0.5	2	#10-24 UNC x 0.5	2	#10-24 UNC x 0.5	2	#10-24 UNC x 0.5	SCREW, SLOTTED PAN HEAD	
34	4	#10-32 x 0.5	4	#10-32 x 0.5	4	#10-32 x 0.5	4	#10-32 x 0.5	WHIZ BOLT	
35	4	#10-32 NF	4	#10-32 NF	4	#10-32 NF	4	#10-32 NF	WHIZ NUT	
36	1	102-075	1	102-075	1	102-075	1	102-075	BRAKE MONITOR ASSEMBLY	

BRAKE MONITOR SWITCH ADJUSTMENTS

WARNING: THIS BRAKE MONITOR SWITCH MUST BE PROPERLY ADJUSTED & FULLY OPERATIONAL PRIOR TO BEING PLACED INTO SERVICE

- 1.) When properly adjusted, contacts A & D open when Brake is energized, and all contacts A thru D are made when the Brake is de-energized.
- 2.) **GAP BETWEEN RODS:** When Brake is energized, and without opening contacts A & D, adjust gap between rods to approximately 1/16". Adjust both sides equally. Loosen leaf spring locknuts and turn rods in or out to gain 1/16" gap. Re-tighten Locknuts.
- 3.) **CAM ADJUSTMENTS:** (NOTE: PRIOR TO ADJUSTING CAMS, LOOSEN CAM JAM NUTS SO CAMS CAN BE TURNED.) With Brake Energized, adjust Outside Cams (A & D) to open Outside Contacts 3/32". Next, De-energize Brake and adjust Inside Cams (B & C) until they just touch Inside Contacts, then turn Inside Cams away one and one half (1 & 1/2) turns (3/32"). Tighten each Cam Jam Nut to prevent further Cam movement. When properly adjusted, contacts A & D open when Brake is energized with a gap between the rods, and all contacts A thru D are made when the Brake is de-energized.

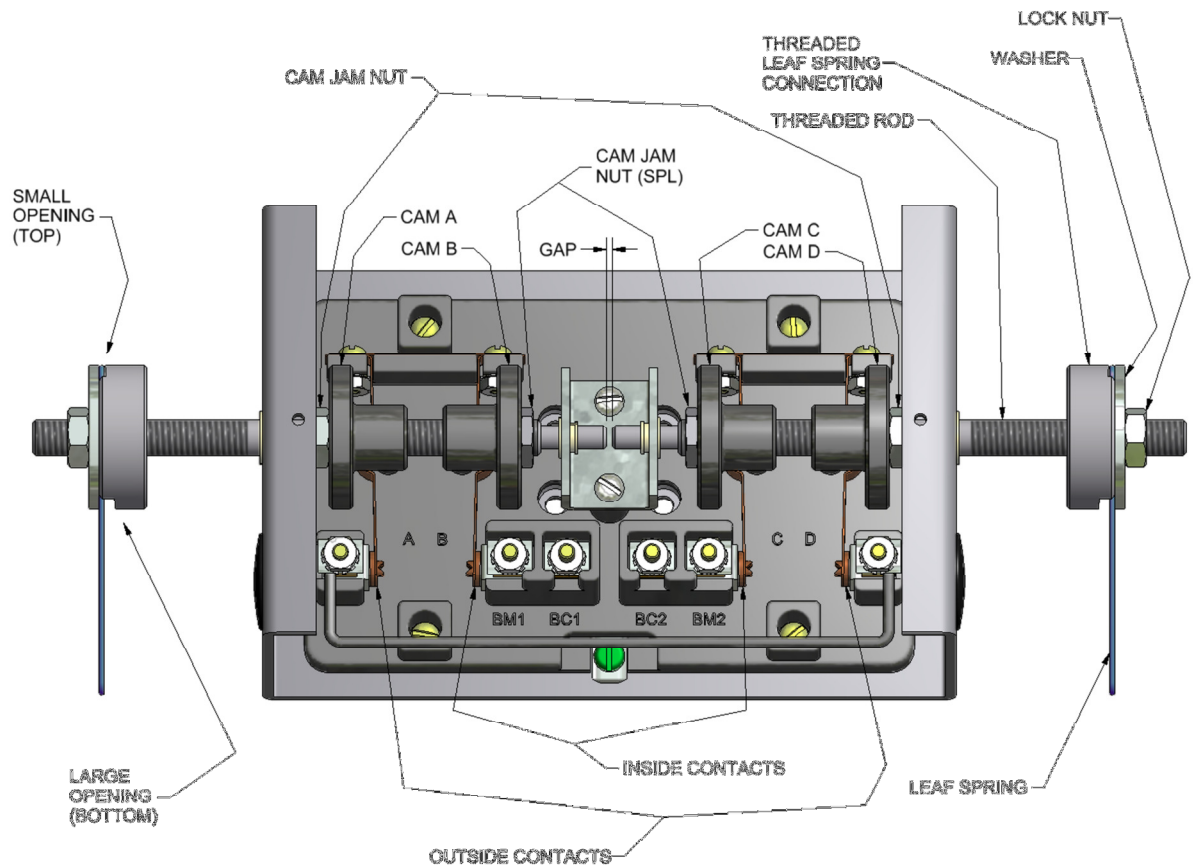

4.) **BRAKE FAILURE:** DO NOT RE-ADJUST THE BRAKE MONITOR SWITCH UNTIL THE BRAKE PROBLEM HAS BEEN CORRECTED AND THE BRAKE RE-ADJUSTED.

- a.) If both contacts A and D fail to open with Brake energized, failure indicates improper pick up which can cause lining wear. Re-check Brake voltages, air gaps, alignment and freedom of arm and plunger movement, etc. To test this failure, place a jumper across terminals BM1 and BM2. The controls should remove the elevator from service in some fashion.
- b.) If contact A or D stays opened when Brake drops, failure indicates improper drop out caused by a bind (find bind and correct). To test, hold open contacts A or D, when elevator stops it should not be able to start.
- c.) If contacts B or C open when Brake drops, this indicates either worm shaft movement (check thrust bearings etc.) or brake lining wear. If cause is normal lining wear, re-adjust Brake including spring tension, air gap, and centering screws, then re-adjust Brake Monitor Switch. To test open contacts B or C elevator should not be able to start.

NOTE: BRAKES MUST BE INSPECTED DURING NORMAL ELEVATOR MAINTENANCE. IF LININGS INDICATE WEAR, THEN SPRINGS, GAPS AND MONITOR SWITCH MUST BE RE-ADJUSTED ACCORDINGLY. ANY ADJUSTMENT MADE TO BRAKE MIGHT AFFECT BRAKE MONITOR ADJUSTMENT.