



G.A.L. Manufacturing Corporation
50 East 153rd Street, Bronx, N.Y. 10451
Phone (718) 292-9000 Fax (718) 292-2034

05/09/00





G.A.L. Manufacturing Corporation
50 East 153rd Street, Bronx, N.Y. 10451
Phone (718) 292-9000 Fax (718) 292-2034

05/09/00



① WESTINGHOUSE STANDARD TRACK

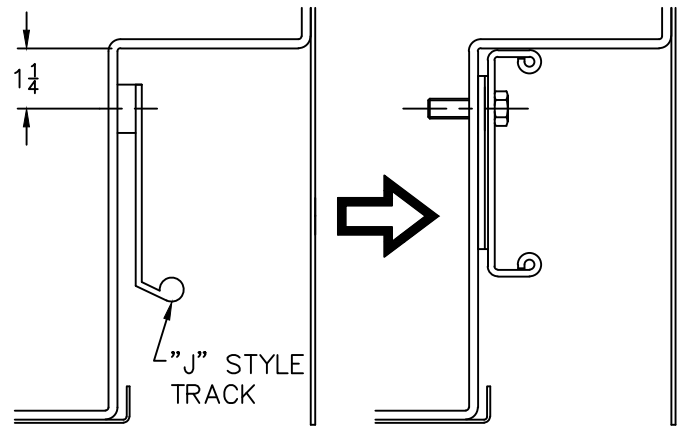

- REMOVE EXISTING "J" STYLE TRACK
- REUSE HEADER, DUST COVER AND OLD TRACK MOUNTING DRILLINGS

② WESTINGHOUSE INTEGRAL TRACK

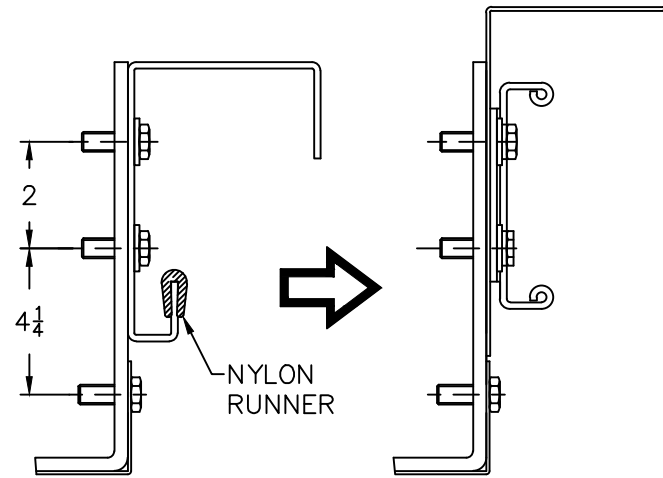

- REMOVE EXISTING TRACK AND DUST COVER
- NEW FASCIA/DUSTCOVER SUPPORT BY G.A.L.
- REUSE OLD TRACK MOUNTING DRILLINGS

③ OTIS STANDARD TRACK

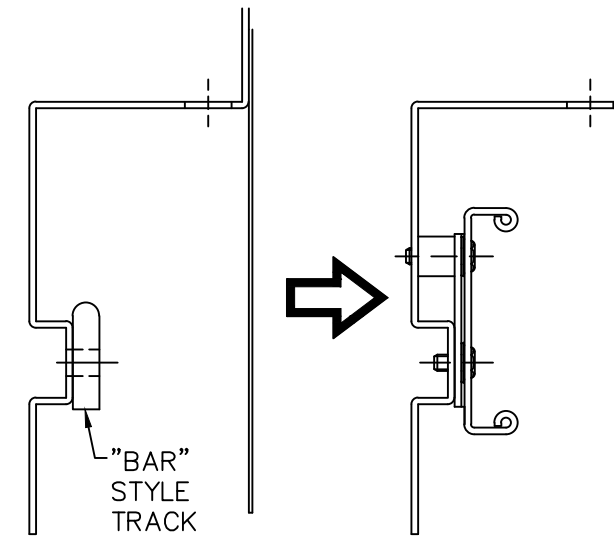

- REMOVE OTIS "BAR" STYLE TRACK
- REUSE EXISTING HEADER AND DUST COVER
- HEADER MUST BE PREDRILLED FOR G.A.L. EQUIPMENT

④ OTIS INTEGRAL TRACK

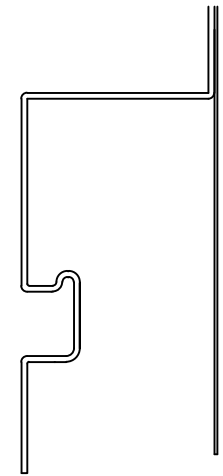

- G.A.L. OFFER NO REPLACEMENT PACKAGE
- NEW HEADER REQUIRED

⑤ WESTINGHOUSE STANDARD DOORS

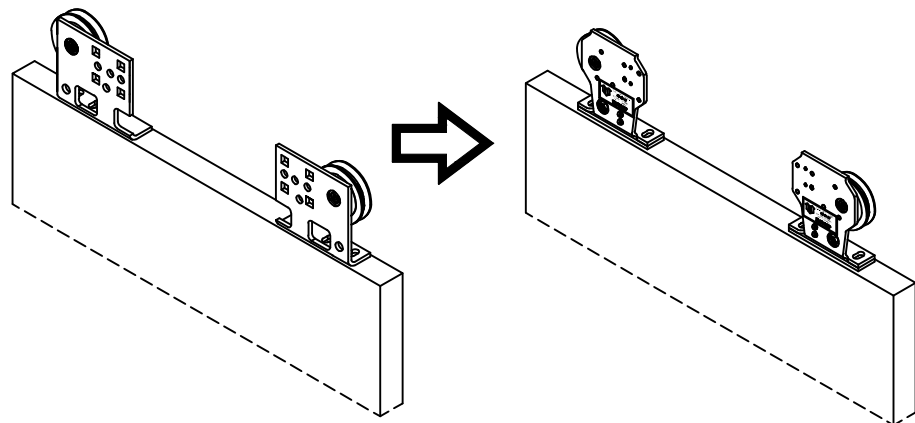

(EITHER 2 1/2 (5A) OR 3 3/4 (5B) INCH CENTERLINES)

- ADAPTOR BARS OR 3 3/4 SHEAVES PROVIDED BY G.A.L.

⑥ WESTINGHOUSE INTEGRAL DOORS

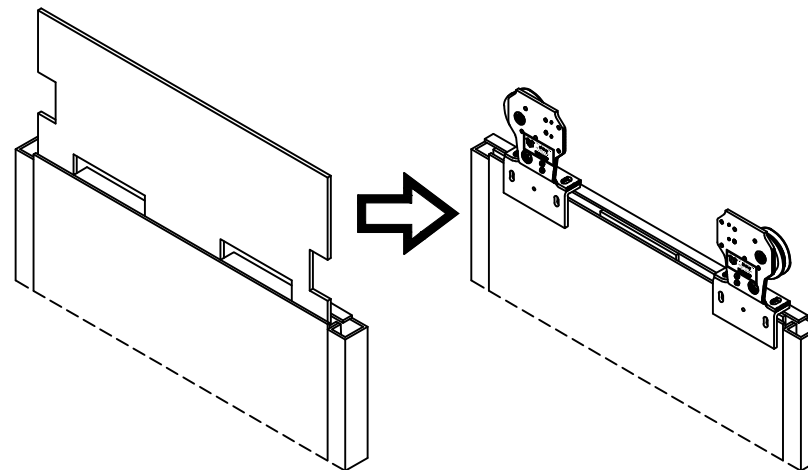

- EXISTING DOOR MUST BE CUT
- SHEAVE MOUNTING BRACKETS BY G.A.L.

⑦ OTIS INTEGRAL DOORS

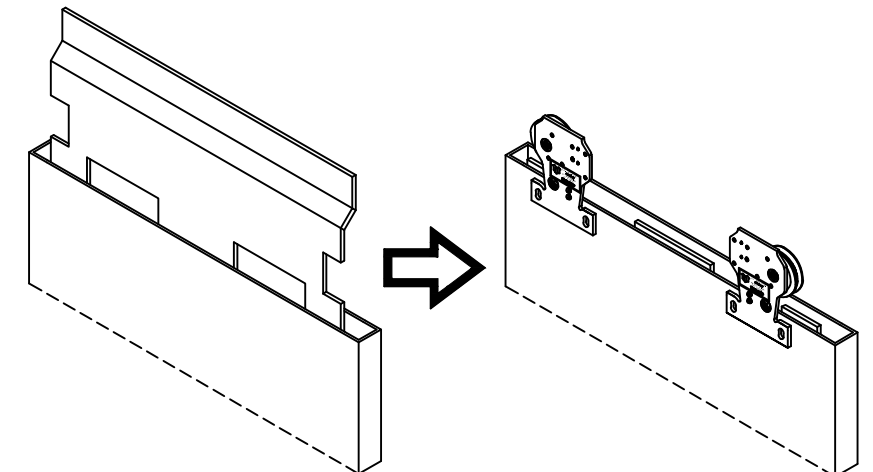

- EXISTING DOOR MUST BE CUT
- DRILL AND TAP SIDE OF DOORS TO MOUNT FLAT SHEAVES OF G.A.L.

SELECTING YOUR REPLACEMENT PACKAGE:

TYPE OF DOOR	TYPE OF TRACK		
	① WESTINGHOUSE STANDARD	② WESTINGHOUSE INTEGRAL	③ OTIS STANDARD
⑤A WESTINGHOUSE STANDARD 2 1/2 SHEAVES	WESTINGHOUSE TYPE "IV"	WESTINGHOUSE TYPE "V"	N/A
⑤B WESTINGHOUSE STANDARD 3 3/4 SHEAVES	WESTINGHOUSE TYPE "II"	N/A	N/A
⑥ WESTINGHOUSE INTEGRAL	N/A	WESTINGHOUSE TYPE "III"	N/A
⑦ OTIS INTEGRAL	N/A	N/A	OTIS TYPE "I"

- WARNING -
G.A.L. PROPRIETARY INFORMATION
REPRODUCTION AND/OR USE OF ALL OR ANY PART OF THIS (THESE) PAGE(S) OR DRAWING(S) OR THE INFORMATION HEREIN, WITHOUT THE EXPRESS PERMISSION OF G.A.L. MANUFACTURING CORPORATION IS STRICTLY PROHIBITED BY LAW.
- VIOLATORS WILL BE PROSECUTED -

REV	DESCRIPTION	DATE
A	TEMPLATE UPDATE	12-10-14

HATCH REPLACEMENT PACKAGES
WESTINGHOUSE AND OTIS



G.A.L. MANUFACTURING CORP.
50 E. 153rd STREET, BRONX, N.Y. 10451
PHONE: (718) 292-9000, FAX: (718) 292-2034
www.GAL.com, info@GAL.com

DATE 08-24-2004
DOCUMENT No. 8359

REV
A

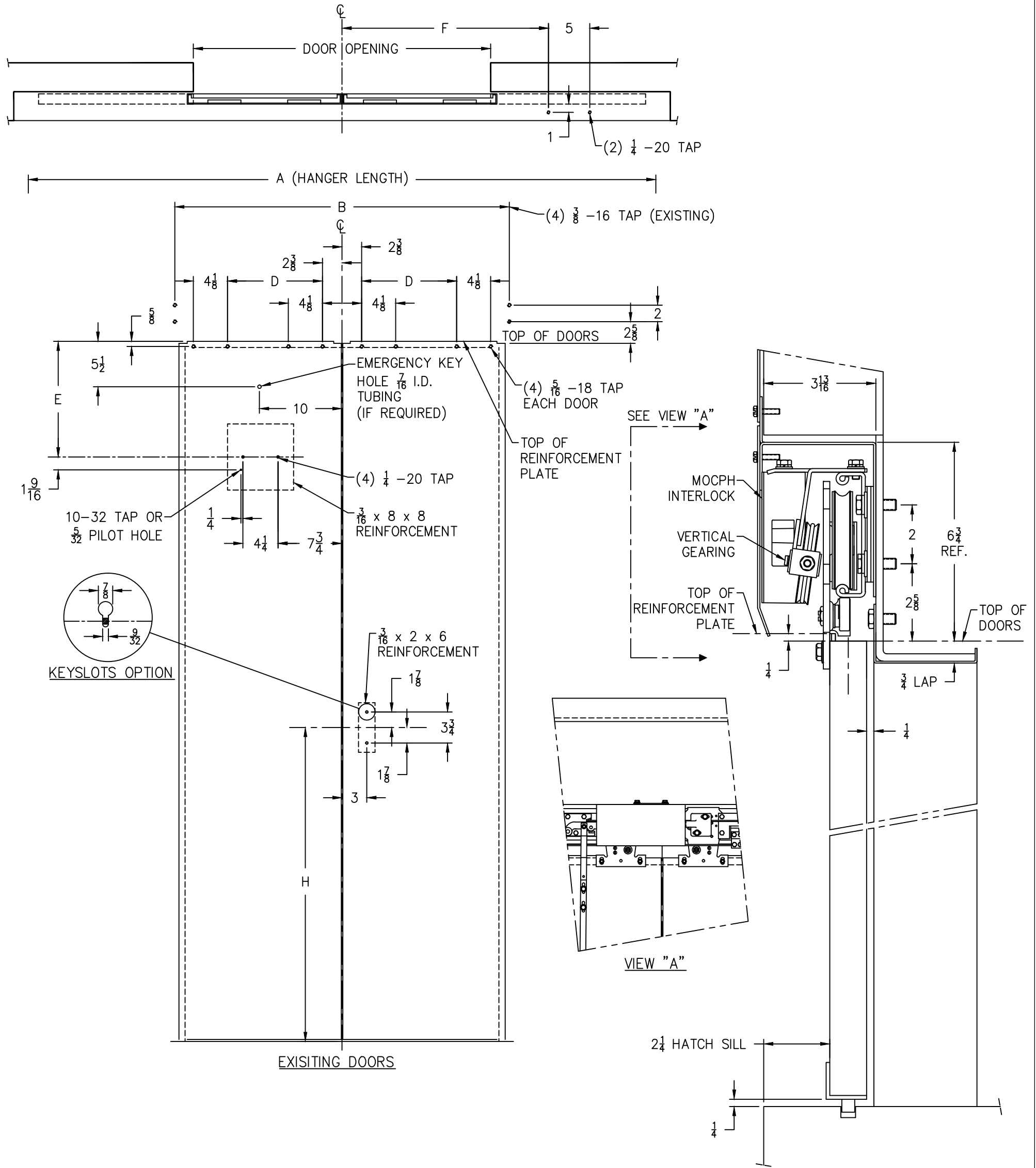

DIMENSION TABLE						
DOOR OPENING	A	B	D	E	H	F
48	100	50½	17½	18	36	29
44	94	-	-	-	-	-
42	88	44½	13½	14	38	25
40	82	42½	12	14	38	25
36	76	38½	10½	10	38	25

NOTE:

DRAWINGS ARE BASED ON EQUAL CAR AND HOISTWAY DOOR HEIGHTS ±1 INCH. IF DOOR HEIGHTS DIFFER, NOTIFY G.A.L. AND HOISTWAY DOOR MANUFACTURER.

36 x 84 DOOR OPENING SHOWN

DOOR HEIGHT _____

JAMB HEIGHT _____

- WARNING -
G.A.L. PROPRIETARY INFORMATION
REPRODUCTION AND/OR USE OF ALL OR ANY PART OF THIS (THESE) PAGE(S) OR DRAWING(S) OR THE INFORMATION HEREIN, WITHOUT THE EXPRESS PERMISSION OF G.A.L. MANUFACTURING CORPORATION IS STRICTLY PROHIBITED BY LAW.
- VIOLATORS WILL BE PROSECUTED -

REV	DESCRIPTION	DATE
B	LAYOUT & TEMPLATE UPDATE	06-05-14
A	48 D.O. "B" DIM 50½ WAS 52	05-22-01

HATCH REINFORCEMENT AND DRILLINGS CENTER OPENING TYPE "A" HANGER WITH SPRING DOOR CLOSER REPLACING EXISTING WESTINGHOUSE III INTEGRAL HANGER VERTICAL GEARING



G.A.L. MANUFACTURING CORP.
50 E. 153rd STREET, BRONX, N.Y. 10451
PHONE: (718) 292-9000, FAX: (718) 292-2034
www.GAL.com, info@GAL.com

DATE 03-08-1996

DOCUMENT No.

8243-7

REV

B

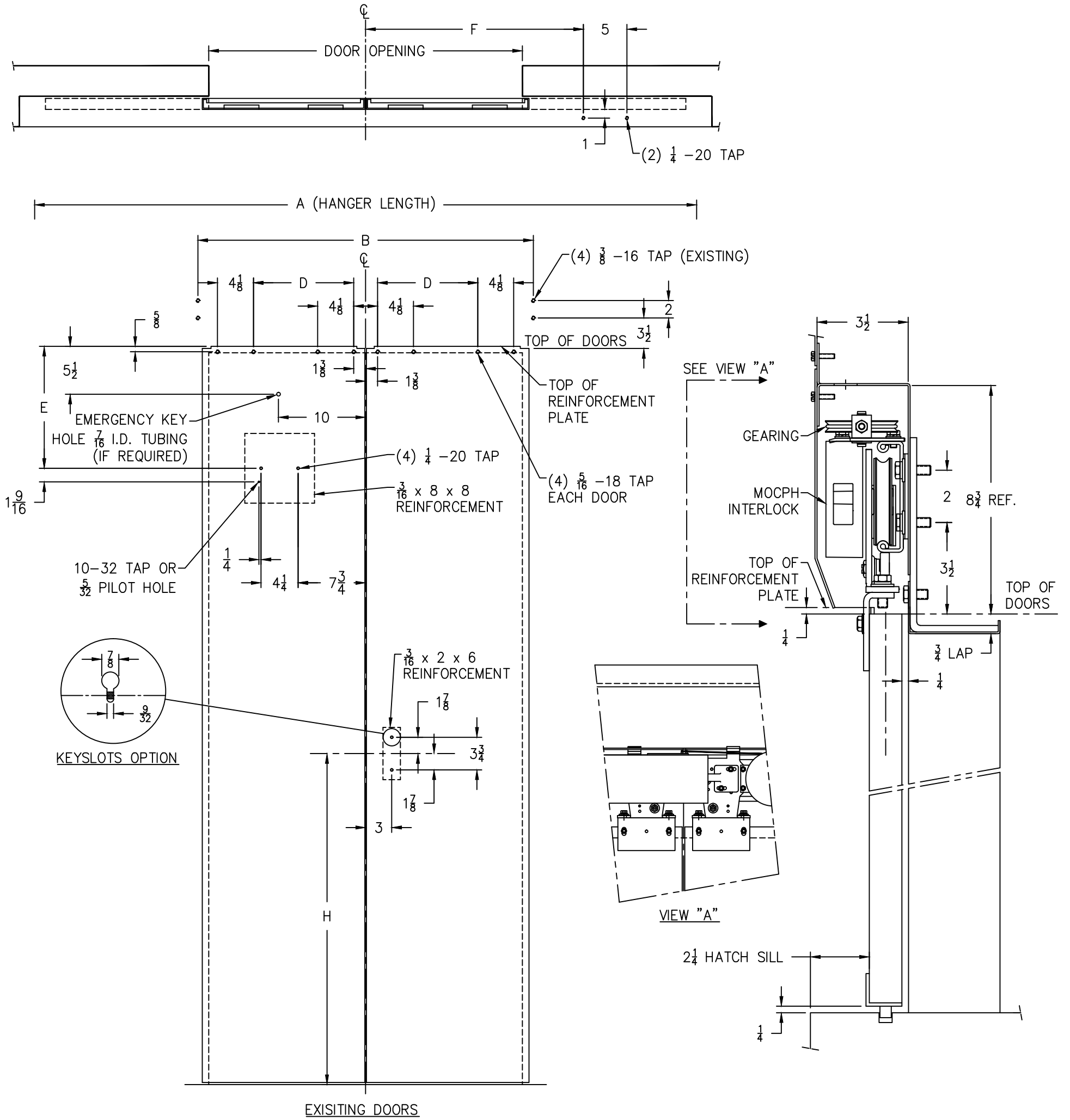

DIMENSION TABLE						
DOOR OPENING	A	B	D	E	H	F
54	106	56 1/2	17 1/2	18	36	29
48	100	50 1/2	17 1/2	14	36	29
42	88	44 1/2	14 1/2	14	38	25
40	82	42 1/2	13	14	38	25
36	76	38 1/2	11 1/2	10	38	25

NOTE:

DRAWINGS ARE BASED ON EQUAL CAR AND HOISTWAY DOOR HEIGHTS ±1 INCH. IF DOOR HEIGHTS DIFFER, NOTIFY G.A.L. AND HOISTWAY DOOR MANUFACTURER.

36 x 84 DOOR OPENING SHOWN

DOOR HEIGHT _____

JAMB HEIGHT _____

- WARNING -
G.A.L. PROPRIETARY INFORMATION
REPRODUCTION AND/OR USE OF ALL OR ANY PART OF THIS (THESE) PAGE(S) OR DRAWING(S) OR THE INFORMATION HEREIN, WITHOUT THE EXPRESS PERMISSION OF G.A.L. MANUFACTURING CORPORATION IS STRICTLY PROHIBITED BY LAW.
- VIOLATORS WILL BE PROSECUTED -

REV	DESCRIPTION	DATE
C	ADDED VERTICAL DIM TO KEY HOLE	06-03-14
B	LAYOUT & TEMPLATE UPDATE	06-03-14
A	48 D.O. "B" DIM 50 1/2 WAS 52	01-02-01

HATCH REINFORCEMENT AND DRILLINGS CENTER OPENING TYPE "A" HANGER WITH SPRING DOOR CLOSER REPLACING WESTINGHOUSE III INTEGRAL HANGER



G.A.L. MANUFACTURING CORP.
50 E. 153rd STREET, BRONX, N.Y. 10451
PHONE: (718) 292-9000, FAX: (718) 292-2034
www.GAL.com, info@GAL.com

DATE	02-22-1996	REV	C
DOCUMENT No.	8243-8		

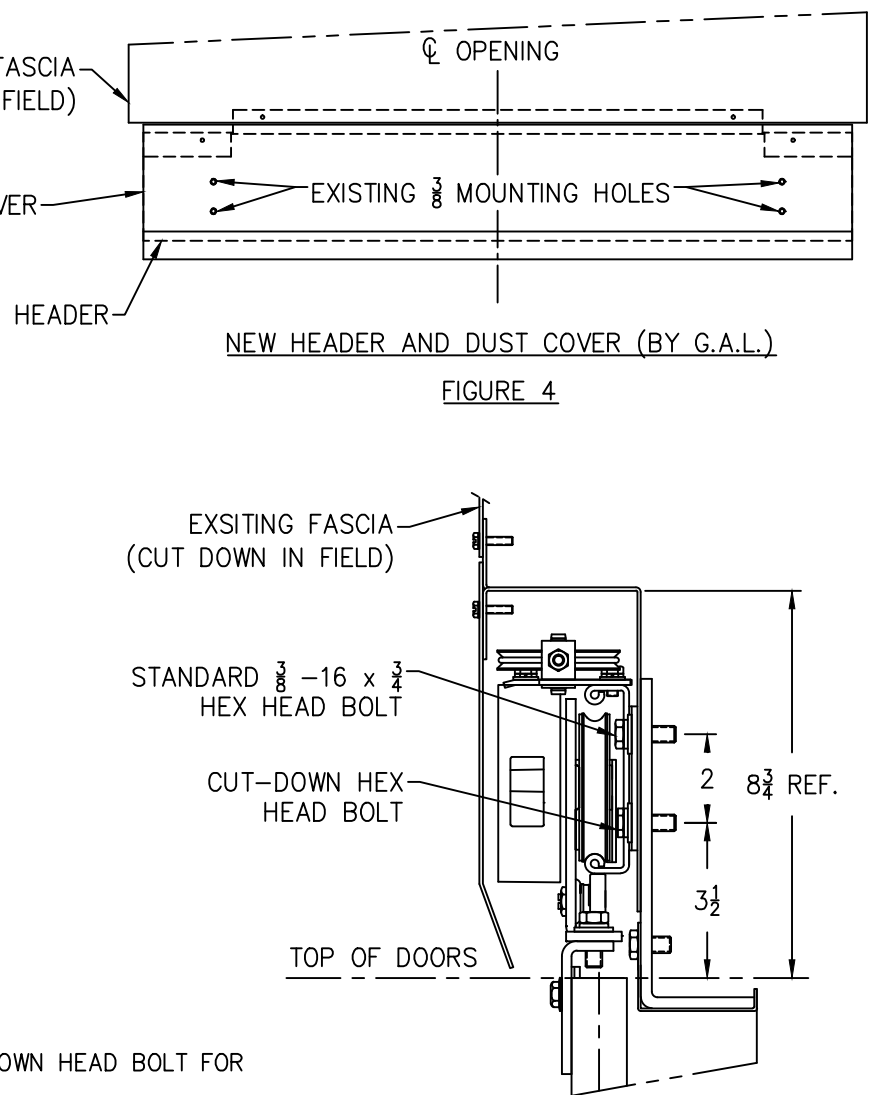
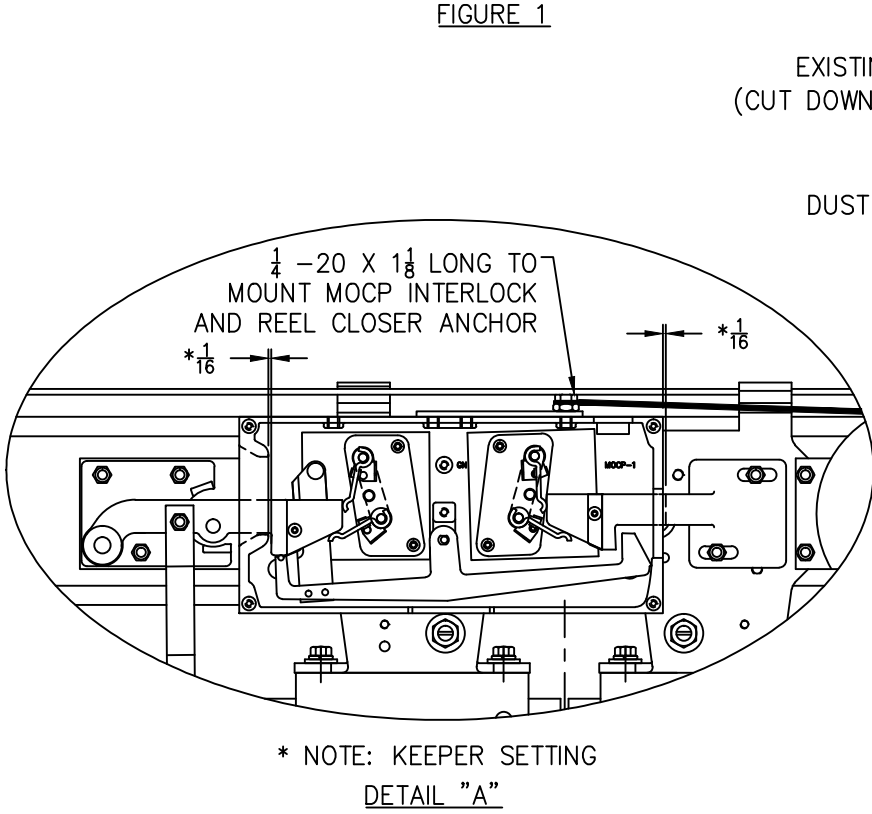
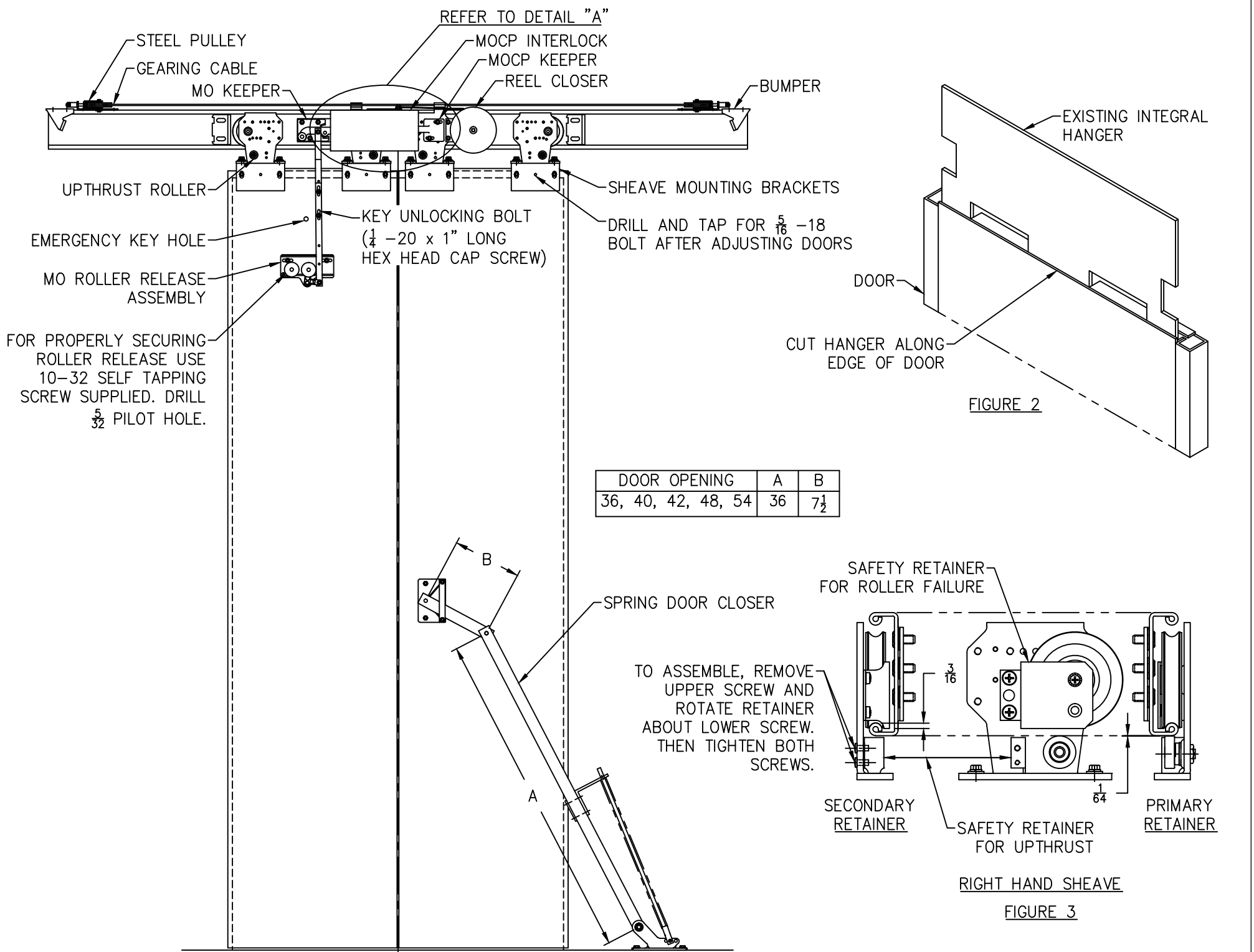

INSTALLATION INSTRUCTIONS:

1. REMOVE EXISTING DOORS, HEADER AND DUST COVER.
2. MOUNT NEW HEADER AND TRACK TO EXISTING MOUNTING HOLES. USE SPECIAL CUT DOWN HEAD BOLT FOR LOWER HOLE.
3. CUT THE FASCIA TO SUIT NEW HEADER.
4. CUT DOWN INTEGRAL HANGERS AS PER FIGURE 2.
5. DRILL DOORS, SEE DRAWING 8243-8, AND HANG DOORS.
6. USE SLOTS ON SHEAVE MOUNTING BRACKETS TO CORRECT DOOR TO SILL CLEARANCE AND DOOR MISALIGNMENT.
7. DRILL AND TAP USING HOLE IN SHEAVE MOUNTING BRACKET TO SECURE SHEAVES IN PLACE.

- WARNING -
G.A.L. PROPRIETARY INFORMATION
REPRODUCTION AND/OR USE OF ALL OR ANY
PART OF THIS (THESE) PAGE(S) OR DRAWING(S)
OR THE INFORMATION HEREIN, WITHOUT THE
EXPRESS PERMISSION OF G.A.L. MANUFACTURING
CORPORATION IS STRICTLY PROHIBITED BY LAW.
- VIOLATORS WILL BE PROSECUTED -

REV	DESCRIPTION	DATE
A	LAYOUT & TEMPLATE UPDATE	06-03-14



CENTER OPENING HATCH DOOR ASSEMBLY
TYPE "A" HANGER WITH SPRING OR REEL CLOSER 36-42 DOOR OPENING
REPLACING EXISTING WESTINGHOUSE III INTEGRAL HANGER

G.A.L. MANUFACTURING CORP.
50 E. 153rd STREET, BRONX, N.Y. 10451
PHONE: (718) 292-9000, FAX: (718) 292-2034
www.GAL.com, info@GAL.com

DATE 02-21-1996
DOCUMENT No. 8253-4

REV
A

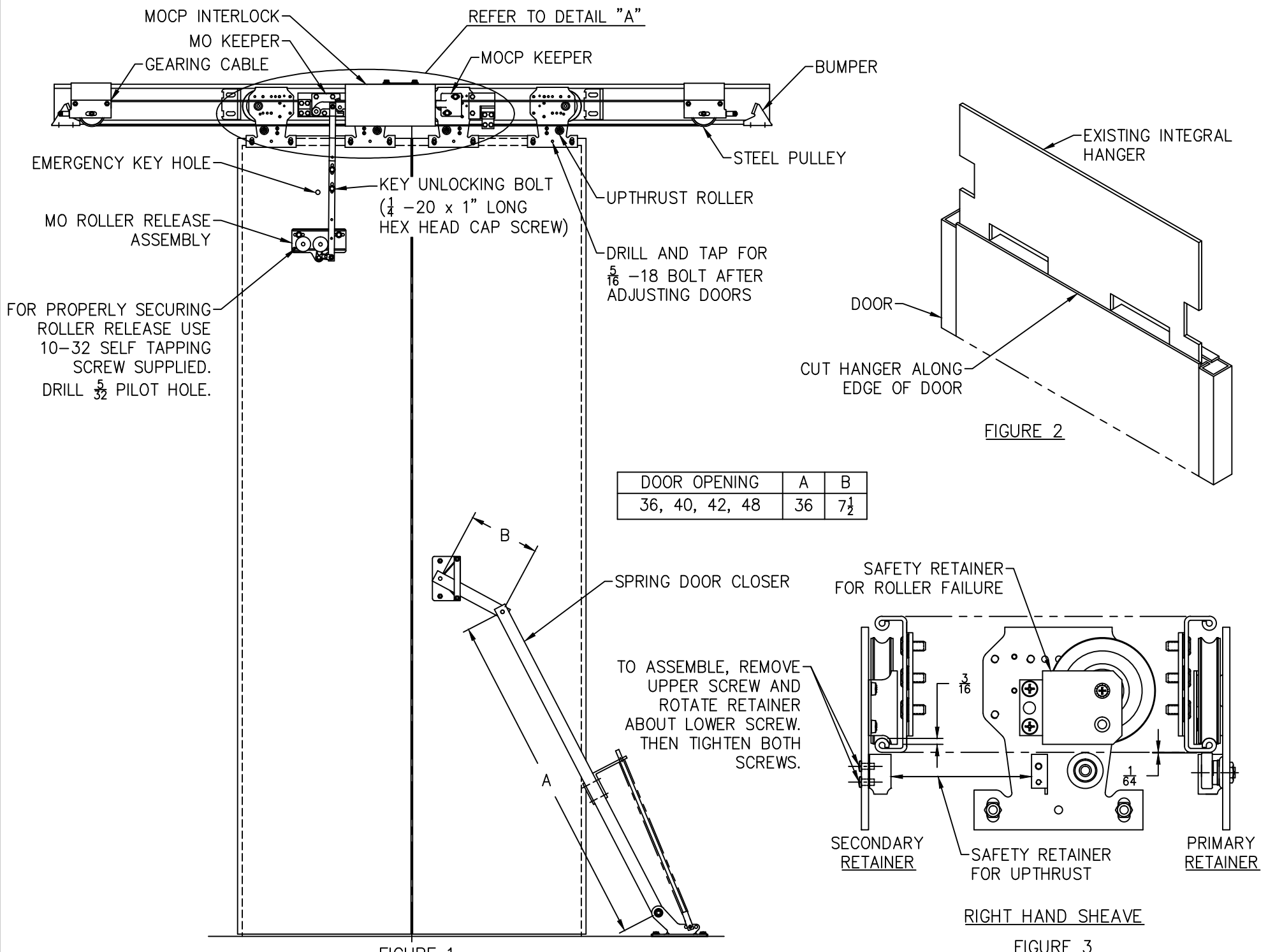

DOOR OPENING	A	B
36, 40, 42, 48	36	7 1/2

FIGURE 1

FIGURE 2

FIGURE 3

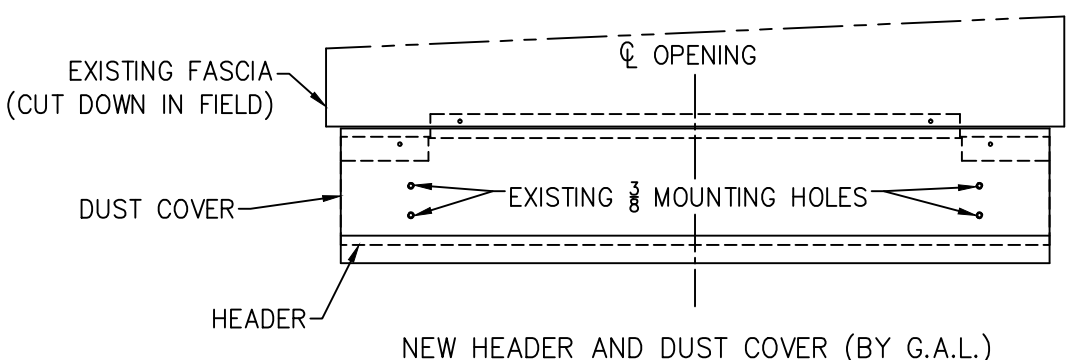
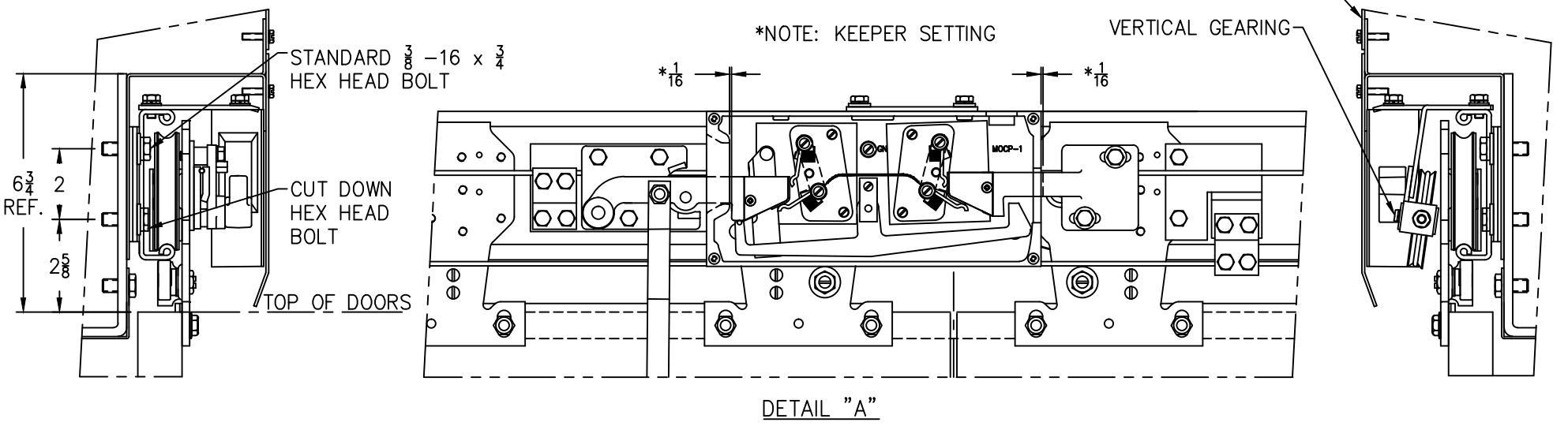

FIGURE 4



DETAIL "A"

INSTALLATION INSTRUCTIONS:

1. REMOVE EXISTING DOORS, HEADER AND DUST COVER.
2. MOUNT NEW HEADER AND TRACK. USE SPECIAL CUT DOWN HEAD BOLT FOR LOWER HOLE.
3. CUT THE FASCIA TO SUIT NEW HEADER.
4. CUT DOWN INTEGRAL HANGER AS PER FIGURE 2.
5. DRILL DOORS, SEE DRAWING 8243-7 AND HANG DOORS.
6. USE SLOTS ON SHEAVE TO CORRECT DOOR TO SILL CLEARANCE AND DOOR MISALIGNMENT.
7. DRILL AND TAP USING HOLE IN SHEAVE TO SECURE SHEAVES IN PLACE.

36 x 84 DOOR OPENING SHOWN

- WARNING -
G.A.L. PROPRIETARY INFORMATION
REPRODUCTION AND/OR USE OF ALL OR ANY PART OF THIS (THESE) PAGE(S) OR DRAWING(S) OR THE INFORMATION HEREIN, WITHOUT THE EXPRESS PERMISSION OF G.A.L. MANUFACTURING CORPORATION IS STRICTLY PROHIBITED BY LAW.
- VIOLATORS WILL BE PROSECUTED -

REV	DESCRIPTION	DATE
A	DRAWING & TEMPLAT UPDATE	06-03-14

CENTER OPENING HATCH DOOR ASSEMBLY
REPLACING EXISTING WESTINGHOUSE III INTEGRAL HANGER VERTICAL GEARING

G.A.L. MANUFACTURING CORP. 50 E. 153rd STREET, BRONX, N.Y. 10451 PHONE: (718) 292-9000, FAX: (718) 292-2034 www.GAL.com, info@GAL.com	DATE 04-19-1995 DOCUMENT No. 8253-5	REV A
---	---	-----------------