



HYDRAULIC ELEVATOR CONTROLLER MANUAL



GAL Manufacturing Corp
50 E 153rd Street
Bronx NY 10451

FORWARD

G.A.L. has developed this manual with usability and safety in mind. General and specific safety notices and precautions are defined in the manual. However, G.A.L. cannot be responsible for any injury to persons or damage to property (including the elevator equipment) resulting from negligence, misuse of the equipment, misinterpretation of instructions included in this manual, or due to any other cause beyond the control of G.A.L.

All drawings, illustrations and information herein are the proprietary property of G.A.L. and must not be made public or reproduced by any individual or entity other than the purchaser hereof without the express written permission of G.A.L.

(REV. February 9, 2006)

TABLE OF CONTENTS

IMPORTANT WARNINGS AND NOTES	VI
1 GENERAL PRODUCT DESCRIPTION.....	1
1.1 INTRODUCTION.....	1
1.2 PHYSICAL LAYOUT OF THE CONTROLLER	2
1.3 SELECTOR SYSTEM	3
1.3.1 SLOWDOWN MAGNETS	3
1.3.2 SECONDARY SPEED FEEDBACK.....	3
1.4 MODES OF OPERATION.....	9
1.4.1 OPERATING SEQUENCE.....	9
1.4.2 RESET MODE	9
1.4.3 SAFETY STRING OPEN MODE.....	10
1.4.4 CONTROLLER INSPECTION MODE.....	10
1.4.5 CAR TOP INSPECTION MODE	10
1.4.6 ACCESS MODE	10
1.4.7 INDEPENDENT SERVICE MODE.....	11
1.4.8 LOAD WEIGHING BYPASS MODE.....	11
1.4.9 ATTENDANT SERVICE MODE.....	11
1.4.10 CODE BLUE HOSPITAL SERVICE MODE	11
1.4.11 FIRE SERVICE PHASE I MODE.....	12
1.4.12 FIRE SERVICE PHASE I ALTERNATE RETURN MODE	12
1.4.13 FIRE SERVICE PHASE II MODE.....	13
1.4.14 EMERGENCY POWER.....	13
1.4.15 EARTHQUAKE MODE	13
1.4.16 STALLED (LOW OIL) MODE	13
1.4.17 AUTOMATIC MODE	14
2 INSTALLATION OF THE GALAXY CONTROLLER	15
2.1 GENERAL INFORMATION	15
2.2 SITE SELECTION.....	15
2.3 ENVIRONMENTAL CONSIDERATIONS	15
2.4 WIRING GUIDELINES AND INSTRUCTIONS	15
2.4.1 THE WIRING PRINTS	15
2.4.2 GROUND WIRING.....	15
2.4.3 HOISTWAY WIRING	15
2.4.4 ELEVATOR CAR WIRING.....	15
2.4.5 MACHINE ROOM WIRING.....	16
2.4.6 WIRING TO TOP OF CAR SELECTOR	16
2.5 SLOWDOWN LIMIT SWITCHES.....	16
2.6 NORMAL AND FINAL LIMIT SWITCHES.....	16
3 ADJUSTMENT OF THE GALAXY HYDRAULIC CONTROLLER.....	18
3.1 GENERAL INFORMATION	18
3.2 INITIAL POWER-UP	18
3.2.1 CHECK MAIN-LINE VOLTAGE	18
3.2.2 SET TOGGLE SWITCHES	18

3.2.3	MAKE SURE THE CAR IS SAFE	18
3.2.4	CHECK CONTROLLER VOLTAGE	18
3.2.5	VERIFY THE LCD GALaxy IS BLINKING	18
3.2.6	PRESET ADJUSTABLE VARIABLES ON SAFETY PROCESSOR BOARD.....	18
3.2.7	PLACE STOP SWICTH IN RUN POSITION.....	19
3.2.8	PUMP MOTOR ROTATION.....	19
3.2.9	READY TO RUN ON INSPECTION.....	19
3.2.10	CHECK SELECTOR INPUTS	20
3.2.11	VERIFY SLOWDOWN LIMITS.....	20
3.2.12	VERIFY CAR SPEED ON SAFETY PROCESSOR BOARD.....	21
3.3	FINAL ADJUSTMENT	21
3.3.1	AUTOMATIC RUN	21
3.3.2	SET FLOOR DEAD ZONE.....	21
3.3.3	ADJUST VALVE	21
3.3.4	ADJUST SAFETY PROCESSOR BOARD SPEED CLAMPS.....	22
3.3.5	VERIFY INSPECTION VELOCITY CLAMP ON SAFETY PROCESSOR BOARD	22
3.3.6	ENABLE DOORS.....	22
3.3.7	FINE TUNE RIDE AND STOPS.....	22
3.3.8	FINE TUNE PARAMETERS	22
4	TROUBLESHOOTING.....	23
4.1	GENERAL INFORMATION	23
4.2	MICROPROCESSOR CPU	23
4.3	INPUT/OUTPUT BOARDS	23
4.4	RUN SEQUENCE	25
4.5	THE SAFETY PROCESSOR BOARD.....	26
4.6	SYSTEM FAULTS	28
4.6.1	MAIN CPU FAULTS.....	28
4.6.2	DETAILED FAULT DATA	58
4.6.3	SAFETY PROCESSOR FAULTS	64
5	LCD DISPLAY INTERFACE.....	66
5.1	OPERATING THE LCD INTERFACE.....	66
5.2	THE LCD MENU STRUCTURE.....	68
5.2.1	SET DATE AND TIME	69
5.2.2	ADJUSTABLE VARIABLES.....	70
5.2.3	JOB STATISTICS	78
5.2.4	INPUTS AND OUTPUTS	81
5.2.5	SET CALLS AND LOCKOUTS	84
5.2.6	ELEVATOR STATUS.....	90
5.2.7	FAULT LOG	93
5.2.8	ELEVATOR SETUP.....	96
5.2.9	SELECT VIDEO DISPLAY	98
5.2.10	SOFTWARE VERSION.....	99
5.2.11	DIAGNOSTICS.....	99
6	SAFETY PROCESSOR LCD DISPLAY INTERFACE.....	107
6.1	OPERATING THE LCD INTERFACE.....	107
6.2	THE SAFETY PROCESSOR BOARD LCD MENU STRUCTURE.....	109
6.2.1	ELEVATOR SERVICE	110
6.2.2	CAR SPEED	111
6.2.3	SAFETY PROCESSOR PULSE COUNT.....	111
6.2.4	SAFETY PROCESSOR ADJUSTABLE VARIABLES	112

6.2.5	SAFETY PROCESSOR INPUTS AND OUTPUTS	115
6.2.6	LIMIT VELOCITY	118
6.2.7	SAFETY PROCESSOR FAULTS	119
6.2.8	CLEAR FAULTS	122
6.2.9	RESET SAFETY PROCESSOR FAULT LATCH	122
6.2.10	SAFETY PROCESSOR BOARD TEMPERATURE	123
6.2.11	EXTERNAL TEMPERATURE	123

APPENDIX A 124

Description of I/O Mnemonics	124
I/O Locations	128

IMPORTANT WARNINGS AND NOTES

The label **WARNING** denotes operating procedures and practices that may result in personal injury and/or equipment damage if not correctly followed.

The label **Note** denotes procedures, practices or information which is intended to be immediately helpful and informative.

WARNING: Installation and wiring must be in accordance with the national electrical code, all local codes, and elevator codes and regulations. The 3 phase A.C. power supply to the equipment must come from a properly fused disconnect or circuit breaker (not capable of delivering more than 10,000 rms symmetrical amperes). Improper motor branch circuit protection will void warranty and may create a hazardous condition.

WARNING: Wiring to the controller terminals must be done in a careful, neat manner. Stranded wire conductors must not have strands left out of the terminals. Leaving strands of wire out of the terminals creates potential shorts. All terminals and cable connectors must be seated properly. Flat cable connectors pin #1 (arrow symbol on connector) must match the red stripe on the cable.

WARNING: Elevator control products must be installed by experienced field personnel. This manual does not address code requirements. The field personnel must know all the rules and regulations pertaining to the safe installation and running of elevators, and local codes.

WARNING: This equipment is an O.E.M. product designed and built to comply with ASME A17.5 and

national electrical code and must be installed by a qualified contractor. It is the responsibility of the contractor to make sure that the final installation complies with any local codes and is installed safely.

WARNING: Proper grounding is vitally important to the safe and successful operation of this system. Bring a separate ground wire for each controller from the building ground to the ground lug on the controller. You must choose the proper conductor size and minimize the resistance to ground by using shortest possible routing. See National electrical code article 250-95, or the related local applicable code.

WARNING: Use only the correct rated fusing for controller protection. Use of over rated fusing will void the warranty.

NOTE: Every precaution, whether specifically stated here or not, should be taken when installing, adjusting or servicing any elevator. Common sense safety precautions should be followed to make sure life and limb of the service person and public is not endangered.

NOTE: Keep the machine room clean. Do not install the controller in a dusty area. Do not install the controller in a carpeted area. Keep room temperature between 32 F and 110 F. Avoid condensation on the equipment. Do not install the controller in a hazardous location and where excessive amounts of vapors or chemical fumes may be present. Make sure power line fluctuations are within +/- 10 percent.

1 GENERAL PRODUCT DESCRIPTION

1.1 INTRODUCTION

The **GALaxy** hydraulic elevator controller is a computer-based system that offers superior performance, flexibility and reliability. It has been designed to save time in installation and troubleshooting, but it is still very important that the field personnel who work with this equipment familiarize themselves with this manual before attempting to install the equipment.

SPECIFICATIONS:

Environment:

- 35 °F to 110 °F ambient
- 12,000 ft altitude
- 95% humidity

Standard Features:

- CSA B44.1-96 ASME A17.1-1996,
ASME 17.1-2000 Certified
- Inspection Operation (car top and controller)
- Access Operation
- Independent Service
- Earthquake Service
- Emergency Power
- Fire Service Phase I
- Fire Service Phase I Alternate Return
- Fire Service Phase II
- Low Oil
- On Board Diagnostic LEDs
- On Board LCD Display Interface
- Two Motor Protection Timers
- Door Motor Protection Timer
- Several Field Adjustable Parameters (Door Times, Lobby, etc.)
- Elevator Duty Rated Nema Motor

Optional Features:

- Selective Rear Doors
- Attendant Service
- Code Blue Hospital Service

1.2 PHYSICAL LAYOUT OF THE CONTROLLER

Figure 1.1 shows a typical layout of the GALaxy controller in a standard G.A.L. cabinet. Below, is a brief description of each block:

1. 1038 Main Control Board: The main control board contains all the input and output devices, controller switches, fuses and field wiring connections.
2. Safety Processor Board: The Safety Processor board uses a microprocessor and a PAL device to implement the independent speed and redundancy checks required for A17.1-2000 compliance. This board has its own LCD display and parameters.
3. Main CPU: The computer board is a single board IBM compatible computer. It executes the program and turns on and off the Inputs and Outputs.
4. LCD Display: The LCD display board provides a user interface to all controller adjustment and setup parameters. It also shows diagnostic information.
5. Power Supply: The power supply provides power to the computer and its peripheral boards. It is a 5 volt DC regulated power supply rated at 3 amps with over voltage, and short circuit protection.
6. Options: This section of the controller is provided to mount options items such as a PI display driver.
7. System Transformer: The system transformer is located in the lower part of the cabinet. It is usually a 500VA building power to 120 VAC transfer. It is used to convert the building power to a lower voltage for the signals and valve power.
8. Starter: The motor starter is an elevator duty rated Nema contactor or Soft start device.
9. Ground Terminal: The ground terminal block is where the earth ground is attached.

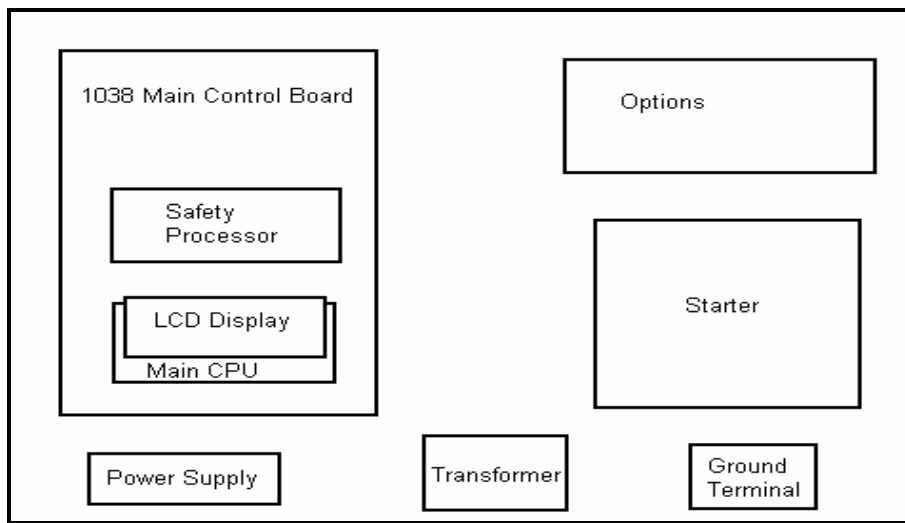

Figure 1.1 Typical Physical Layout

1.3 SELECTOR SYSTEM

The selector system for the GALaxy controller uses a steel tape that is hung the length of the hoistway. A set of magnets are placed on the tape at each floor having one 8" magnet as the door zone magnet and two smaller 2" magnets as slowdowns. The selector is mounted on the car and is guided along the tape by nylon guides to keep the tape and magnets the proper distance from the selector sensors. The controller uses the door zone magnet to determine the elevator's level position to the floor.

The tape is installed by first attaching it at the top of the hoistway approximately 12 inches from the rail, see Figure 1.1. The tape is then unreeled from the top of the car while running down on inspection. At the bottom of the hoistway it is attached with a spring to keep it taut. The selector is then mounted on the top of the car and is connected to the tape by the nylon guides. Figure 1.2 shows a typical mounting of the selector to the crosshead.

To install the floor magnets, the car is placed dead level to the desired floor. The tape is then marked at the top left of the selector through a factory cut guide hole. The car is moved below the floor so the tape can be accessed where the selector was sitting at floor level. A door zone template, provided by G.A.L., is placed at the mark and the door zone magnet is placed at the appropriate locations in the template. The template is then removed from the tape. The slowdown magnets are then placed at the measured distance on the tape above and below the floor. The location of each magnet is shown in Figure 1.3.

1.3.1 SLOWDOWN MAGNETS

The slowdown magnets are used to signal the CPU to transfer to leveling speed (to turn off the high speed output). Table 1.0 shows the slowdown magnet distances with respect to contract speed. All distances are show in inches.

Fpm	US, DS
100	20"
150	30"
200	40"
250	50"

Table 1.0: Slowdown Distances

1.3.2 SECONDARY SPEED FEEDBACK

The tape is perforated with 3/8 inch holes every 3/8 of an inch. A sensor is mounted on the selector to provide a secondary speed feedback to the Safety Processor Board. The Safety Processor uses this velocity to verify that the car is traveling at a safe speed when slowdown limits are hit, when the car doors are open and when running on inspection.

There are three type of inputs used to verify the car speed at the terminal landing. Traction cars with distance feedback use the normal slowdown limits "UT & DT" and the emergency slowdown limits "UTS & DTS". Hydro and traction non-distance feedback cars use the level sensors from the selector "UL & DL" at the terminal landings for the velocity check and are validated with "UTS & DTS" emergency slowdown limits. For all control systems, the "UT & DT" limits are used to verify the operation of "UTS & DTS".

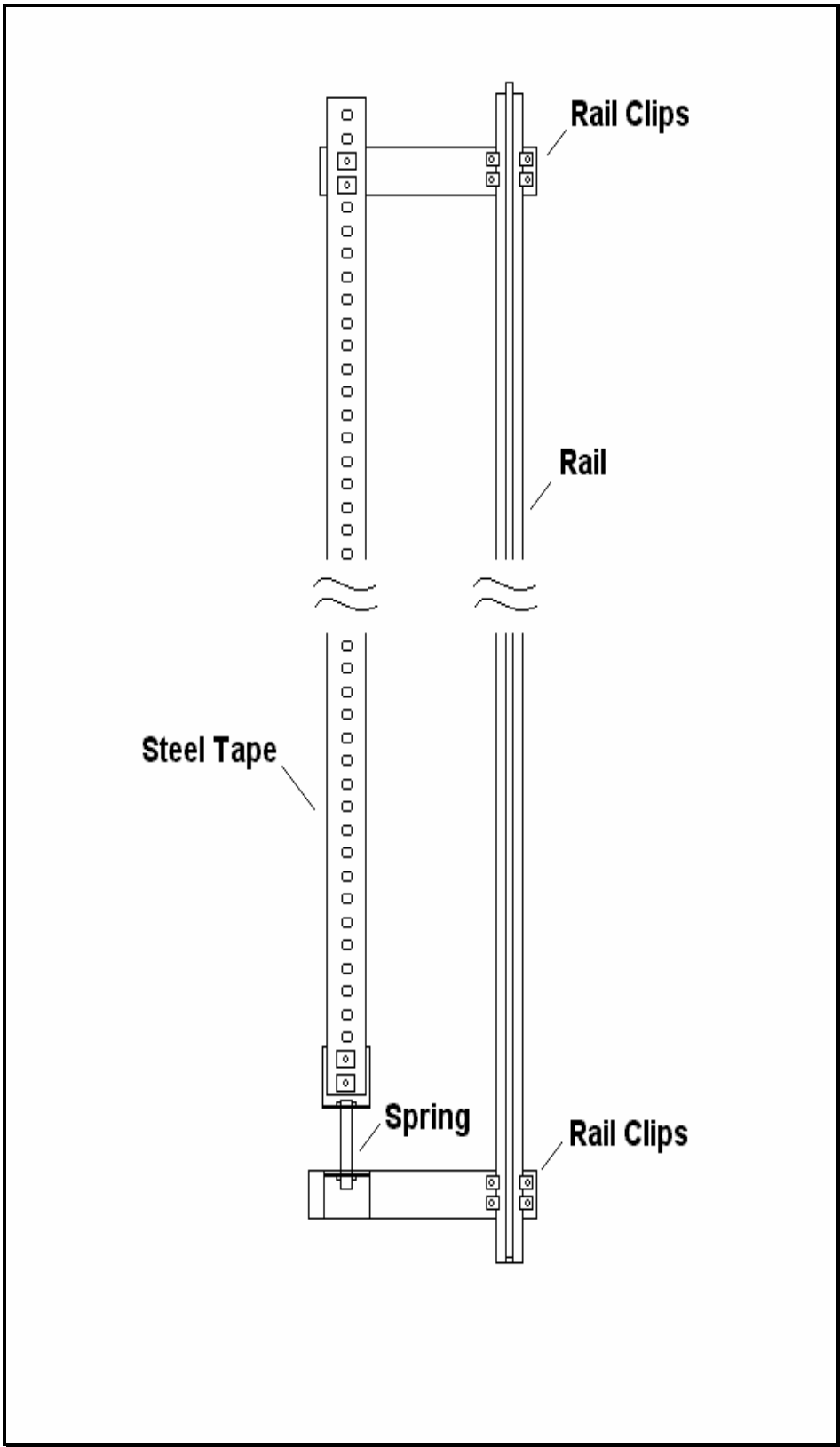

Figure 1.2: Typical Tape Mounting

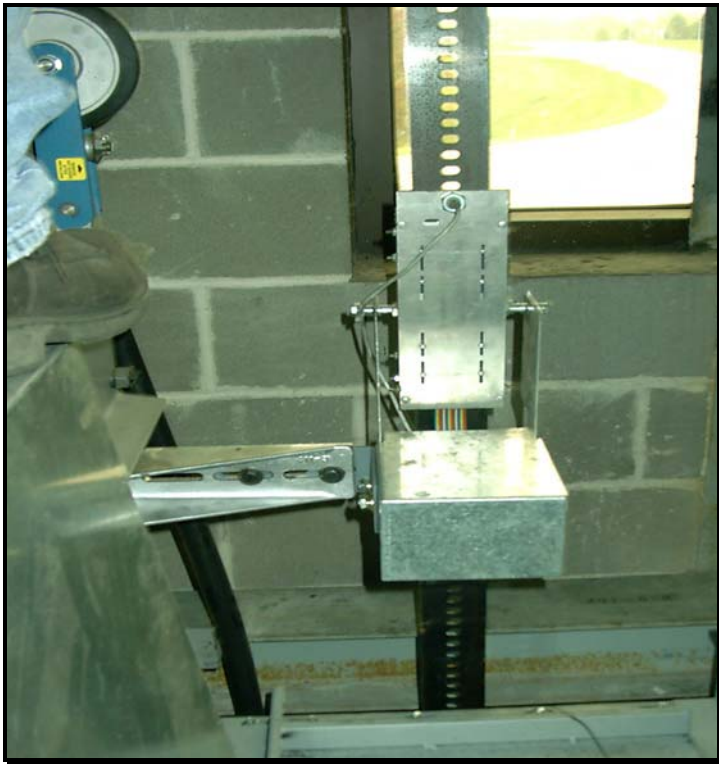

Figure 1.3: Typical Mounting of Selector

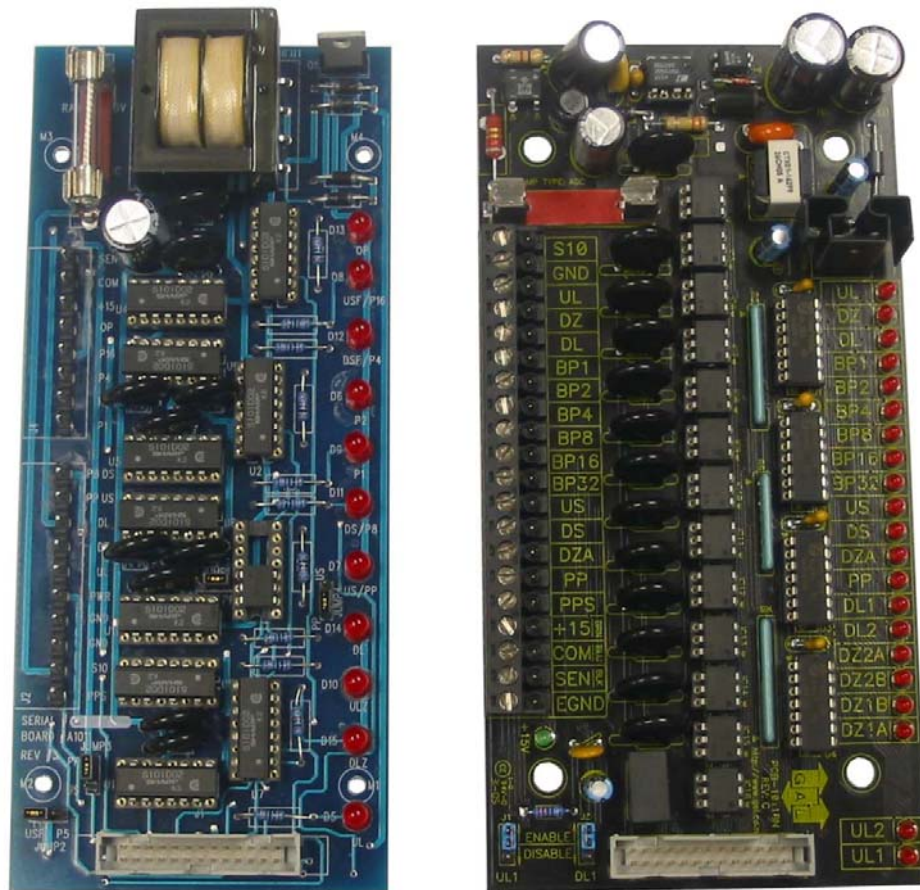

Figure 1.3a – Selector Boards

Depending on the type of selector board you have the selector magnet placement will vary. If you have the selector board on the left in Figure 1.3a then you need to follow the selector magnet placement shown in Figure 1.4. If you have the

selector board on the right in Figure 1.3a then you need to follow the selector magnet placement shown in Figure 1.5. The selector board can be located inside the selector box..

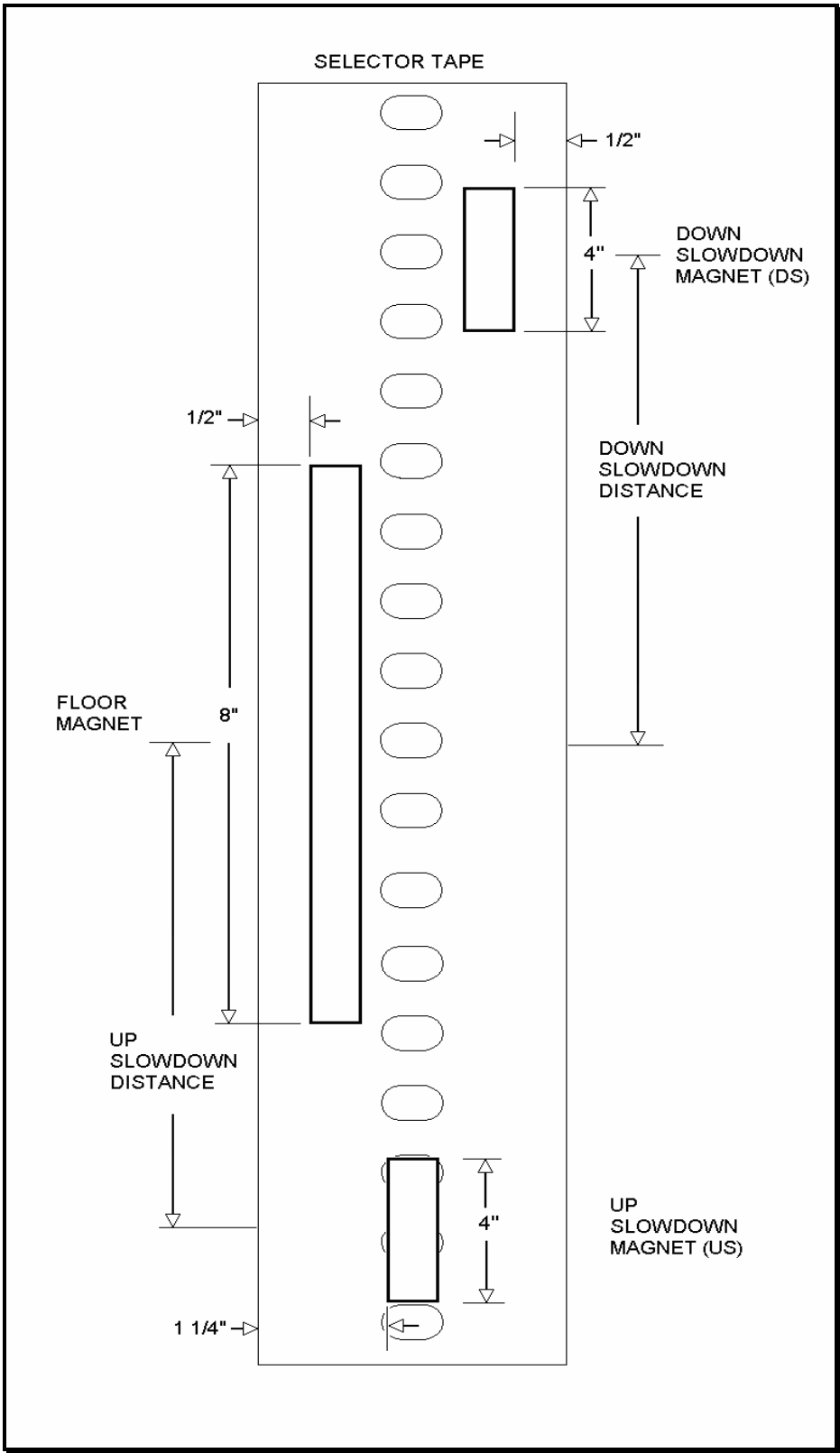

Figure 1.4: Selector Magnet Placement

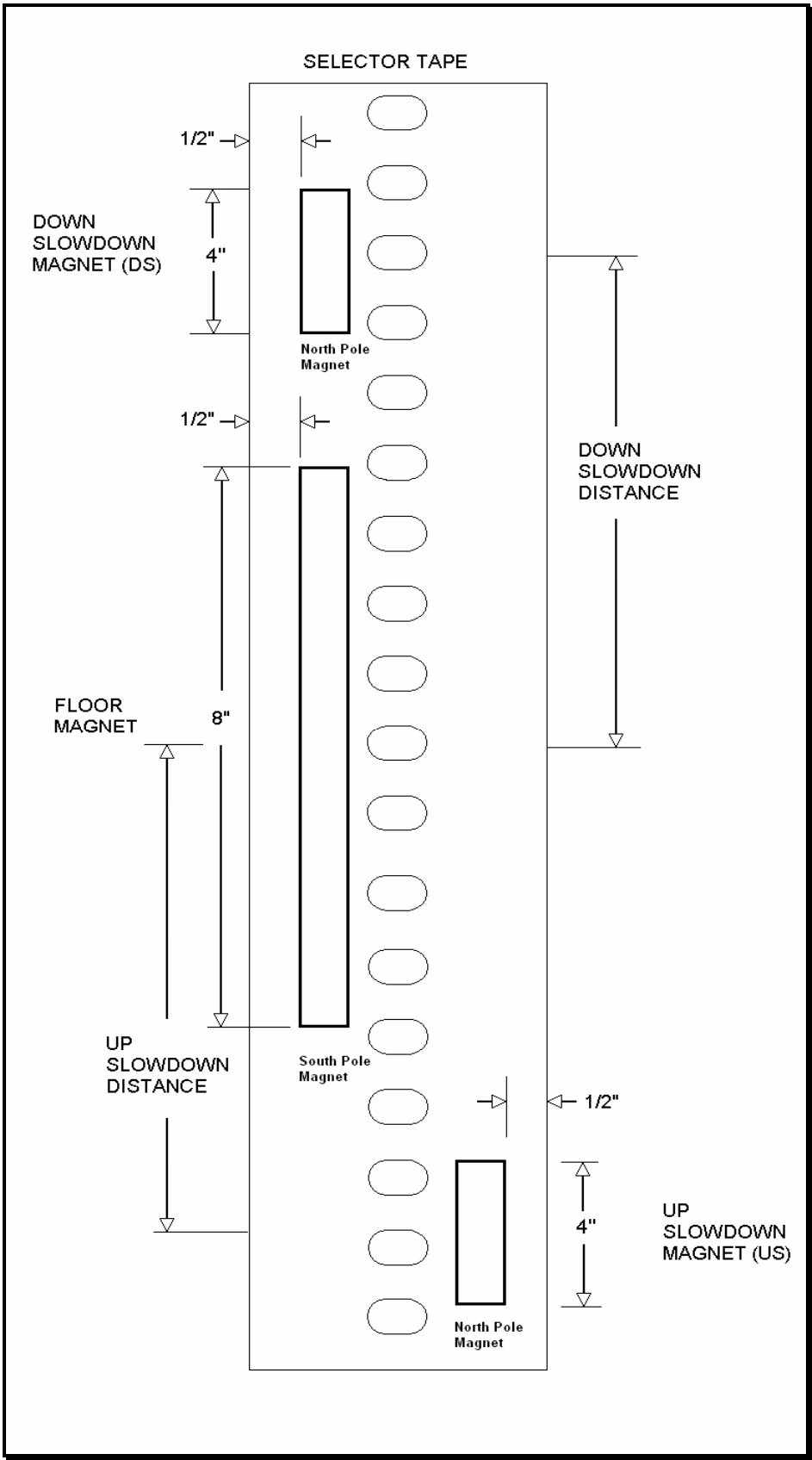

Figure: 1.5: New Selector Magnet Placement

1.4 MODES OF OPERATION

1.4.1 OPERATING SEQUENCE

Normal elevator operation, Automatic Mode, is selective-collective. When the elevator is traveling upwards to answer calls, all up hall calls at floors above the car are answered in the order reached by the car, regardless of the order in which the calls were registered. Upon reaching each landing with a car call or hall call registered, the car and hall doors at that floor are automatically opened.

The doors stay opened for a dwell time that is field adjustable. There are three different dwell times depending on whether it is a lobby call, car call, or hall call. The door will close before the set dwell time has elapsed if a passenger presses the door close button. The door will reopen before it is fully closed if the door open button is pressed, if a passenger pushes on the safety edge, if the photo-eye light beam is interrupted, or if a call for that floor in the direction of travel is pushed. The door will close when the door opening condition is eliminated. When the door has fully closed, the calls are answered.

When all up hall calls and car calls above the car have been answered, the elevator reverses direction and travels downward to answer car calls and down hall calls placed below the car. The calls are answered as previously described for up calls. When all calls below a down car are answered, the car reverses direction to repeat the cycle. In short, an elevator traveling up will bypass down hall calls, and an elevator traveling down will bypass up hall calls.

In buildings with more than one elevator grouped together, the actual time of arrival, "real time", is used to estimate how long each elevator will take to answer a hall call. The elevator that can respond the fastest takes the call. Real time based dispatching permits the controllers to quickly respond to actual demand for elevator service. Some of the criteria used to estimate the time of arrival are listed below.

- Actual elevator floor to floor run times.
- Actual run time to the floor whether it is a multi-floor run or a one floor run.

- Whether the elevator is in or out of service.
- Whether the elevator is in load weigh bypass mode.
- The direction and position of each elevator in the group.
- The average door cycle time at each stop.
- Status of each elevator, accelerating, full speed, decelerating, actual time in motion.
- Number of stops required due to car calls.
- Number of stops required due to previously assigned hall calls.
- System demand.

The above performance criteria is continuously measured and stored for improved accuracy in the dispatching algorithm. All of the above data is continuously scanned and the hall calls are reassigned if the conditions change and another car can respond faster. The ability to measure actual hall waiting time virtually eliminates long waiting and improves the average hall call waiting intervals throughout the building.

1.4.2 RESET MODE

Reset mode is initiated when the elevator power is first turned on, or when the system is reset. When the reset mode is initiated, the controller program is automatically loaded, and internal tests are run to ensure that both the car and controller are electrically operational before putting the car into service. The car will not move until reset mode is completed. Some of the tests are: is the safety string made, is the elevator on inspection operation, is the door close limit open, are the interlocks made up, and whether

the controller knows where the elevator car is within the hoistway. If all the safeties are made up, and the elevator is on automatic operation, and it is floor level, the elevator will go into automatic mode. If the elevator is not at floor level, it will perform a home run to either the top or bottom landing. If the elevator is on the down terminal slowdown, and not on the leveling magnet, it will go to the top landing. If the elevator is anywhere else, it will reset to the bottom floor.

1.4.3 SAFETY STRING OPEN MODE

Safety string open mode is initiated when a safety is open. Some of the safeties are listed below.

- The reverse phase relay.
- The top final
- The bottom final
- The pit switch
- The car top stop switch

When the safety string is made back up, the elevator will go back to reset mode.

1.4.4 CONTROLLER INSPECTION MODE

The controller inspection mode is initiated by placing the “INS” switch on the 1038 board in the inspection position (down). Controller inspection mode permits operation of the car from the machine room. This mode performs the following operations:

- Enables the controller inspection “UP” and “DOWN” pushbuttons.
- Door locks are active and must be closed to move the car.
- Pressing the controller “UP” pushbutton causes elevator to move at inspection speed in the up direction.
- Pressing the controller “DOWN” pushbutton causes the elevator to move

at inspection speed in the down direction.

1.4.5 CAR TOP INSPECTION MODE

This inspection mode is initiated by placing the inspection switch on top of the car in the inspection position. Inspection mode permits operation of the car from the car top inspection station. This mode performs the following operations:

- Disables access top and access bottom hall switches. Disables the controller inspection up and down pushbuttons. Enables the car top inspection station up and down pushbuttons.
- Door locks are active and must be closed to move the car.
- Pressing the inspection station up and safe pushbuttons causes the elevator to move at inspection speed in the up direction.
- Pressing the inspection station down and safe pushbuttons causes the elevator to move at inspection speed in the down direction.

1.4.6 ACCESS MODE

The access mode is initiated by placing the key operated access switch located in the car operating panel to the on position. Access mode allows entrance into the hoistway by qualified and authorized elevator maintenance personnel for equipment inspection and service. Access to the top of the car is possible from the top landing, or to the pit from the bottom landing. Enabling this mode permits the following operation.

- Enables the access key switches at the top and bottom landing in the entrance door jambs.

- Bypasses the gate switch to allow car movement with the car door open.
- Bypasses the top or bottom landing hall door lock, depending on which terminal access switch is being keyed.
- Turning the access key switch to the up position causes the elevator to move at inspection speed in the up direction.
- Turning the access key switch to the down position causes the elevator to move at inspection speed in the down direction.

1.4.7 INDEPENDENT SERVICE MODE

The independent service mode is initiated by placing the key operated independent switch located in the car operating panel to the on position, or by placing the controller toggle switch “IND” to the down position. Independent mode permits operation of the car with an operator. This mode performs the following operations:

- Hall initiated calls are ignored.
- Hall lanterns and gongs are disabled.
- The doors open automatically and stay open until closed by the operator.
- Closing the doors requires constant pressure on the door close button.
- When the car door is closed, the car answers the nearest car initiated call in the direction of travel.

1.4.8 LOAD WEIGHING BYPASS MODE

The load weighing bypass mode is initiated when the car is loaded to a predetermined percentage of full capacity, by closing a connection between terminals “LC” and “LW”. Load weigh bypass mode allows the car to answer car calls and lighten the load before

answering any more hall calls. This mode performs the following operations:

- Hall initiated calls are ignored.
- All other elevator functions as if on full automatic service.

1.4.9 ATTENDANT SERVICE MODE

The attendant service mode is initiated by placing the key operated attendant switch located in the car operating panel to the on position. Attendant mode permits operation of the car with an attendant. This mode performs the following operations.

- The doors open automatically and stay open until closed by the attendant.
- Closing the doors requires a momentary pressure on the door close button, or the up or down buttons located in the car operating panel.
- Hall initiated calls are answered unless there is constant pressure on the bypass button.
- Hall lanterns and gongs are enabled.
- The direction of preference can be specified by momentary pressure on the up or down buttons located in the car operating panel.

1.4.10 CODE BLUE HOSPITAL SERVICE MODE

Code blue hospital service mode is initiated by turning one of the code blue switches, located at each floor where medical emergency service is required, to the on position. A car is selected to respond to the code blue call. That car will perform the following:

- Cancel all car calls
- Any hall calls previously assigned will be transferred to another car.

- If traveling toward the code blue call, it will proceed nonstop to the code blue call floor.
- If traveling away from the code blue call, it will slow down and stop at the nearest floor, maintain doors closed, reverse direction and proceed nonstop to the code blue call floor.
- If at a floor other than the code blue call floor, the elevator will close the doors and proceed nonstop to the code blue call floor.
- Once at the code blue call floor, the doors will open and remain open.
- The code blue in car switch located in the car operating panel must then be turned to the on position. If the code blue in car switch is not turned to the on position within 60 seconds from the time the doors reach full open on the code blue call floor, the car will revert back to normal operation.
- Upon activation of the key switch, it will allow the car to accept a car call for any floor, close the doors, and proceed nonstop to the floor desired.
- The return of the code blue in car key switch to the normal position will restore the car to normal service.

1.4.11 FIRE SERVICE PHASE I MODE

Fire service phase I is initiated when the primary smoke sensor is activated or the fire key switch located in the hall station on the primary return floor is turned to the on position. The primary return floor is usually the lobby floor, but could be another landing if it better serves the needs of emergency personnel when fighting a fire or performing rescues. When fire service phase I is enabled:

- The fire emergency return light illuminates and the fire buzzer sounds.

- The emergency stop switch is disabled when the door closes.
- The car travels to the primary return floor without answering any calls, then parks with the door open. The fire buzzer turns off, but the fire emergency return light stays illuminated.
- If the car is at a landing with the doors open, the doors will close, and the car will return non-stop to the primary return floor. If the car is traveling away from the primary return floor, the car will stop at the next landing, then go immediately to the primary return floor.
- Turning the fire service key switch to the bypass position will restore the elevator to normal service.
- The elevator will perform per ASME A17.1 section 211.3 unless otherwise specified.

1.4.12 FIRE SERVICE PHASE I ALTERNATE RETURN MODE

Fire service phase I alternate return is initiated when the smoke sensor in front of the elevator at the primary return floor is activated. When fire service phase I alternate return is enabled:

- The fire emergency return light illuminates and the fire buzzer sounds.
- The emergency stop switch is disabled when the door closes.
- The car travels to the alternate return floor without answering any calls, then parks with the door open. The fire buzzer turns off, but the fire emergency return light stays illuminated.
- If the car is at a landing with the doors open, the doors will close, and the car will return non stop to the alternate return floor. If the car is traveling away

from the alternate return floor, the car will stop at the next landing, then go immediately to the alternate return floor.

- Turning the fire service key switch the bypass position will restore the elevator to normal service.
- The elevator will perform per ASME A17.1 section 211.3 unless otherwise specified.

1.4.13 FIRE SERVICE PHASE II MODE

To initiate fire service phase II, the car must first have been placed in fire service phase I, and, as a result, be parked at the designated level with the door fully open. Following that, the key operated fire service phase II switch, located in the car operating panel must be placed in the on position. Fire service phase II permits operation of the car by a fire fighter. This mode performs operations in accordance with ASME A17.1 as follows:

- The doors close only with constant pressure on the door close button, after they have been fully opened.
- The doors open only with constant pressure on the door open button, after they have been fully closed.
- Hall lanterns and gongs are disabled.
- Safety edge and electric eye are disabled
- All registered car calls can be canceled with momentary pressure on the call cancel button located in the car operating panel.
- All hall calls are disabled.
- To remove the car from fire service phase II the car must be at the fire return landing with the doors in the full open position and the phase II switch turned to the off position.

- See ASME A17.1 for specific operation of fire service phase II.

1.4.14 EMERGENCY POWER

Emergency power is initiated when a connection is made between terminals “HC” and “EMP”. This mode is used in buildings that have a backup power system to run at least one elevator in Automatic mode. Emergency power performs the following operations:

- All cars are returned to the bottom floor one at a time, and remain there with their doors open.
- If a car is selected to run it will go back into normal operation.
- Removing the connection between terminals “HC” and “EMP” will remove the cars from emergency power operation.

1.4.15 EARTHQUAKE MODE

Earthquake mode is initiated upon activation of a seismic switch. This mode performs the following operations:

- If in motion the car will proceed to the nearest available floor.
- Open the doors and shut down.

1.4.16 STALLED (LOW OIL) MODE

Stalled mode is initiated when the elevator has been in run mode longer than the field adjustable anti-stall timer. This mode performs the following operations:

- Turns off the pump motor and stops the elevator.
- The car is returned non stop to the bottom floor.

- Upon reaching the bottom floor the doors cycle, then the elevator is shut down.
- The door open button remains active.

1.4.17 AUTOMATIC MODE

Since this is the normal operating mode, the controller automatically enters this mode if none of the previously described modes are activated, and if no fault is detected. The following operations are performed in automatic mode:

- The car operates in selective-collective control sequence when answering calls.

- Hall calls and car calls are functional.
- Hall lanterns and gongs are operational.
- Simplex cars park at the last call answered unless simplex lobby parking has been enabled in the program. In a multi-car group, a car is always parked at the lobby if no other demand exists.
- The doors remain closed when the car is parked.

2 INSTALLATION OF THE GALAXY CONTROLLER

2.1 GENERAL INFORMATION

This section provides basic guidelines and recommendations for the proper installation of the controller equipment. These guidelines should be used as general instructions. They are not intended to usurp local codes and regulations.

2.2 SITE SELECTION

When choosing the installation site of the controller, several factors should be considered. If at all possible, the controller should be installed in a location where the mechanic has a good view of the machine when he is standing in front of the controller. There should be no obstructions around the controller that would prevent proper routing of necessary conduits entering the controller. The controller doors should have enough room to fully open and close. All clearances, working space, lighting, and guarding should comply with governing codes.

2.3 ENVIRONMENTAL CONSIDERATIONS

The standard controller package is provided with a NEMA 1 enclosure. This type of controller should be installed in a clean and dry environment. Ideally, the equipment room should be temperature controlled between 70 and 90 degrees F. However, control equipment will function properly within an ambient temperature range of 35 to 110 degrees F. If temperatures remain at the upper and lower extremes of this range for an extended period of time, the life expectancy of the control equipment may be shortened. If wet, dusty, or corrosive environments are expected, then optional non-

standard enclosures can be provided. For example NEMA 4, NEMA 12, or NEMA 4X.

The control system is designed to have a high immunity to electrical noise, radio frequency radiation, and magnetic interference. However, high levels of these items could cause interference with certain parts of the control system.

The power supply feeding the controller should have a fluctuation of no greater than + or - 10%.

2.4 WIRING GUIDELINES AND INSTRUCTIONS

2.4.1 THE WIRING PRINTS

Each set of wiring schematics is job specific. The job name and number will be listed in the bottom right corner of each page of the print. A separate binder will be provided for each job containing a complete set of wiring schematics.

2.4.2 GROUND WIRING

Proper grounding of the power supply, controller, elevator car, and hoistway is required. Separate conductors should be run for "EG" (earth ground) and "GND" terminals. These terminals and conductors are detailed on the wiring schematics.

2.4.3 HOISTWAY WIRING

All hoistway wiring is detailed on the wiring schematics. The number of hoistway conductors is calculated and listed per job on the wiring schematics. A job specific "pull sheet" is also provided with the wiring schematics.

2.4.4 ELEVATOR CAR WIRING

All elevator car wiring is detailed on the wiring schematics. The number of traveling cable conductors is calculated and listed per job on the

wiring schematics. A job specific “pull sheet” is also provided with the wiring schematics.

2.4.5 MACHINE ROOM WIRING

All machine room wiring is detailed on the wiring schematics. All wire sizes are listed for main power supply, motor wiring, brake wiring (traction only), and field wiring.

2.4.6 WIRING TO TOP OF CAR SELECTOR

The car top selector is wired according to the schematics for the job. However, special attention should be given to wiring the pulse sensor on the selector since the output on this device uses +15VDC. Terminal PPS on the selector is wired to PPS on the controller and selector terminal PP/US is wired to PP on the controller. Note that since the PP/US output on the selector cannot work for both PP and US at the same time, the US and DS functions are wired from USF and DSF on the selector to US and DS respectively on the controller.

2.5 SLOWDOWN LIMIT SWITCHES

There are two types of slowdown inputs used “UT & DT” and “UTS & DTS”. Slowdown switches “UT and DT” are used to open the “ON” command to the high-speed valve at the terminal landings independent of the control of the CPU.

The “UTS & DTS” limit switches are used as slowdown speed verification points by the Safety

Processor board. If the car hits the velocity verification point at a speed greater than the preset speed, power is immediately removed from the pump motor and the motion valves are de-energized for an emergency stop.

The “UT & DT” limit switches are also used as speed verification points by the Safety Processor board. When the limit is first hit, the Safety Processor counts an adjustable number of pulse counts from that point to determine the velocity trip point. Since cars with only one slowdown limit would hit the limit at high speed when recovering from being lost, the extra pulse counts from the limit allows the car to slowdown before the trip point is reached.

The Safety Processor board uses the “UT & DT” limits to verify the operation of the “UTS & DTS” limits. The pulse input is also verified while running on automatic.

The distance that the limits are placed from the terminal landing depends on the speed of the car. Below, Table 2.0 shows the slowdown limit locations with respect to contract speed. All distances are show in inches.

2.6 NORMAL AND FINAL LIMIT SWITCHES

The up and down directional limit switches “UN & DN” should be set to open one inch past the terminal floor levels. The top and bottom final limit switches should be set to open four inches past the terminal floor levels.

Fpm	UT/DT	UT1,2,3/DT1,2,3	UTS/DTS
50	10"	Not Used	8"
100	20"	Not Used	10"
150	30"	Not Used	15"
200	40"	Not Used	20"

Table 2.0: Slowdown Distances from terminal landing.

3 ADJUSTMENT OF THE GALaxy HYDRAULIC CONTROLLER

3.1 GENERAL INFORMATION

Before adjustment begins the following items must be completed.

1. All field wiring and safety circuits installed
2. Temporary jumpers from terminal "HC" to terminals "MES & ALT"
3. All hoistway limit switches installed
4. All car and hoistway doors and interlocks installed and pre-adjusted
5. Selector installed and magnets pre-adjusted
6. Valve pre-adjusted.
7. Familiarize yourself with all wiring schematics

3.2 INITIAL POWER-UP

3.2.1 CHECK MAIN-LINE VOLTAGE

With main-line disconnect in the off position, check the line-side voltage with a volt meter to insure the voltage matches the controller name tag "Input Power" voltage. Check to insure all three phases are present. If voltage is not correct or all three phases are not present, do not proceed until corrected. If voltage and phases are correct, proceed to step "B".

3.2.2 SET TOGGLE SWITCHES

Flip all toggle switches on the 1038 board down except for the car gate bypass and the door lock bypass switches. Flip those two switches up.

3.2.3 MAKE SURE THE CAR IS SAFE

Verify that all elevator doors are closed and that all safety circuits are functional.

3.2.4 CHECK CONTROLLER VOLTAGE

Turn the main-line disconnect to the on position. Check voltage at fuses L1, L2, and L3 (if present) on controller. If correct, check voltage at terminal "LIN" with respect to "GND". Voltage should read 120VAC. If correct, check voltage at terminals "S10, LC, & HC" with respect to "GND". All should read 120VAC. If not, check wiring diagram to determine problem before continuing.

3.2.5 VERIFY THE LCD GALaxy IS BLINKING

Check to make sure that the "axy" of GALaxy on the LCD display is blinking. If the "axy" is blinking, continue to the next step. If not, check voltage at terminals 5V to 0V on the 1010D board to insure 5VDC. If 5VDC is present and the "axy" on the LCD display is not blinking, then contact factory.

3.2.6 PRESET ADJUSTABLE VARIABLES ON SAFETY PROCESSOR BOARD

The safety processor (1028N) board is normally preset prior to leaving the factory, however, it is prudent to check the setup values for the proper settings. Refer to section 6 of this manual for the operation of the safety processor board LCD display interface. The following adjustment variables must be set properly:

Top Spd (contract speed)
Enc RPM (if Fdbk Typ=1)
Enc PPR (if Fdbk Typ=1)

Fdbk Typ (0=tape, 1=enc)
Ctrl Typ (1=Tr NDF, 2=Tract DF)
2 Stop (0=Mult, 1=2 stop)
RearDoor (0=Front only, 1=Rear)
UTS Vel (Set to top speed)
DTS Vel (Set to top speed)
INS Vel (Set to 140)
LEV Vel (Set to 140)
UT Vel (Set to 500)
DT Vel (Set to 500)
UL Vel (Set to 160 if Non-DF)
DL Vel (Set to 160 if Non-DF)
Dmd Mult (Set to 1.000)
SoftStop (Set to 1)

Note that the velocity variables will be setup once the car is running on automatic.

3.2.7 PLACE STOP SWITCH IN RUN POSITION

Flip the "STOP" toggle switch on the 1038 board to the up position. Verify that input LED's for "LC, HC, DN, UN, SS, GTS, RDY and CS" are all on. If not, then correct field wiring.

3.2.8 PUMP MOTOR ROTATION

To check for proper rotation of pump motor, press the inspection "UP" push-button on the 1038 board just long enough for the motor to begin turning. If rotation is correct, continue to

the next step. If rotation is wrong, then swap any two of the three legs feeding terminals "L1, L2, & L3" on the "DEL" contactor. Check to insure rotation is correct and then continue.

3.2.9 READY TO RUN ON INSPECTION

The car should be ready to run on inspection if all is wired correctly. Select the "Elevator Status" on the main CPU board LCD display. The display should show "Out of Service" on the first line and "Inspection Mode" on the second. The LCD display on the Safety Processor Board will display one of the following types of inspection:

"MR INS" (Motor Room)
"CT INS" (Car Top)
"ACCESS" (Access)
"IC INS" (In Car)
"AUTO" (Not on Inspection)

To run the car from the motor room, "MR INS" should be displayed.

The "inspection string" consist of contacts from the inspection switches and the gate and lock bypass switches in series. One and only one of the five inspection inputs should be on for the car to run. Starting from the car top inspection input, the five inspection inputs are, "INS" for car top, "ACC" for access, "ICI" for in-car, "MRI" for motor room, and "AUTO" for automatic (no inspection).

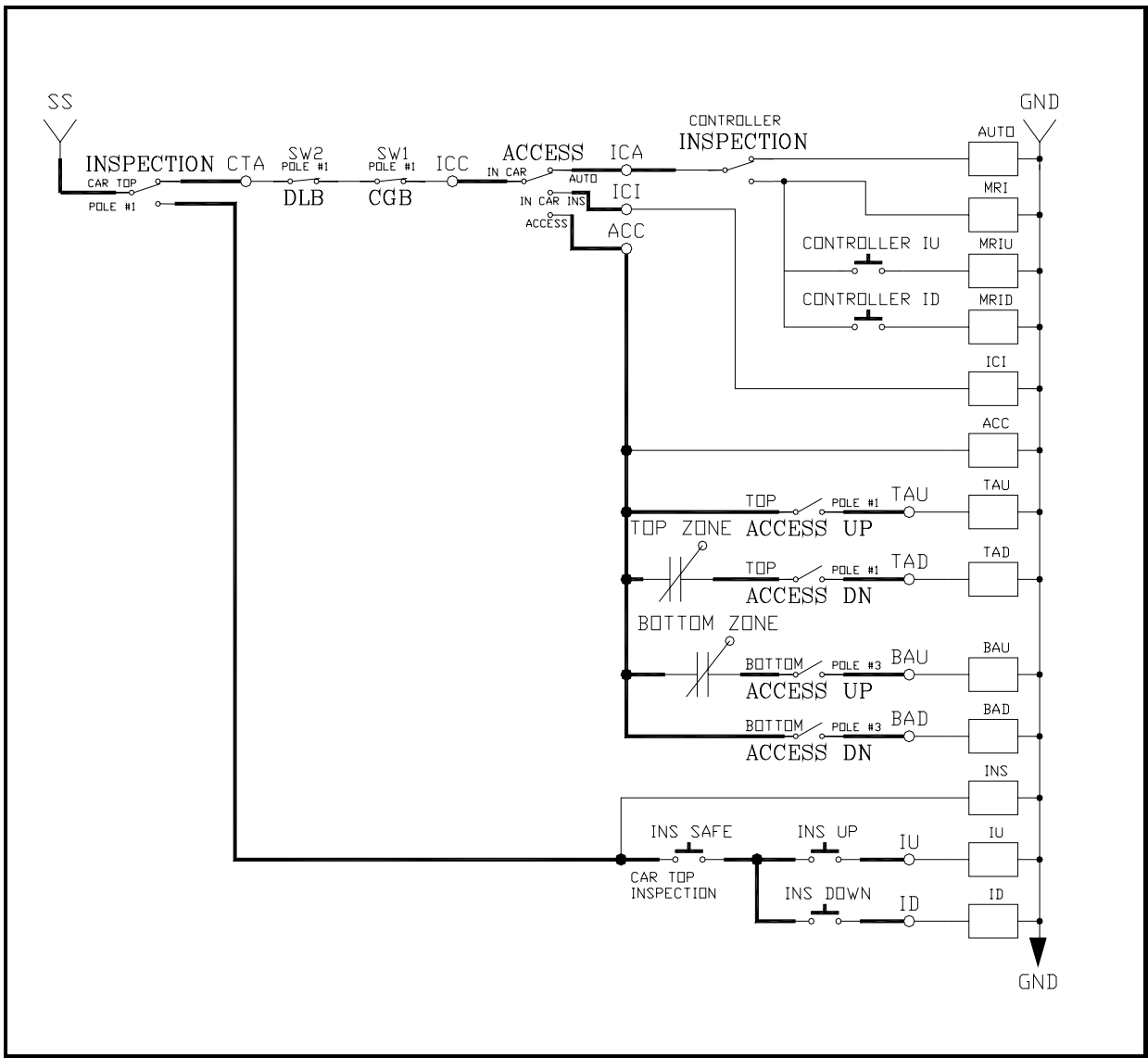

Figure 3.1.

Note that if more than one inspection input is on, if no inspection input is on or if a gate or lock bypass switch is open and the car is not on car top inspection, an inspection error will be displayed on the Safety Processor LCD Display.

If the controller is not on motor room inspection at this point, then verify all switch positions and wiring before proceeding.

3.2.10 CHECK SELECTOR INPUTS

Run elevator on controller inspection to verify proper inputs from the selector. At each floor level the “UL, DL, & DZ” input LED’s should be on. The “US, & DS” input LED’s should

come on when the up & down slowdown magnets are passed.

3.2.11 VERIFY SLOWDOWN LIMITS

As the car is running verify that the up and down slowdown sensors for each floor, “US and DS”, activate prior to reaching the landing. Also verify that the up and down terminal slowdown limits inputs “UT, UTS, DT & DTS” are breaking at the proper distances as shown in the slowdown table 2.0. “US and DS” turn on when active but “UT, UTS, DT & DTS” turn off when active.

“UT & DT” should turn off one inch closer to the terminal floor levels than when the “US & DS” inputs turn on.

3.2.12 VERIFY CAR SPEED ON SAFETY PROCESSOR BOARD

Run the car in either direction and check the car speed on the safety processor LCD display. The speed shown should match the car’s speed actual speed. If the speed does not match and the secondary feedback comes from pulses from the tape go to “Correct Car Speed When Using A Tape”. If the secondary feedback comes from an encoder go to “Correct Car Speed When Using An Encoder”. If the correct speed is shown proceed to the “Final Adjustment” section.

3.2.12.1 CORRECT CAR SPEED WHEN USING A TAPE

The tape has holes every 3/8” that are 3/8” in diameter. The safety processor measures the time between each pulse to calculate the velocity. If the velocity is not displayed correctly first make sure that the feedback type in the safety processor board adjustable variable is set to 0 for a tape application. Next, while the car is running, make sure that the XP LED on this board is pulsing. As the car increases in speed the LED will glow solid on. If the LED does not pulse, try swapping the wires at the PPS and PP terminals. If the LED still does not work, contact the factory. If the correct speed is shown proceed to “Final Adjustment”.

3.2.12.2 CORRECT CAR SPEED WHEN USING AN ENCODER

When using an encoder for the secondary speed feedback, make sure that the adjustable variables on the safety processor board are set properly. Set the feedback type to 1 for encoder and set the encoder RPM and PPR appropriately for how the encoder is driven. If the correct velocity is not obtained, contact the factory. If

the correct speed is shown proceed to the next step.

3.3 FINAL ADJUSTMENT

3.3.1 AUTOMATIC RUN

Run the elevator on controller inspection down until it stops on the down directional limit switch. All toggle switches on the 1038 board should still be in the down position except the “STOP” toggle switch, which should be in the up position. The valve should be pre-adjusted to provide the quickest transitions possible and leveling speeds at approximately 5 to 6 fpm.

With the elevator on controller inspection and on the down directional limit switch, flip the “INS” toggle switch to the up position. If all is correct, the elevator should level up to floor level at the bottom floor. If elevator does level up and stop at the bottom floor then proceed to the next step.

If the elevator does not level up to the floor then verify that the “INS” input LED is on. If “INS” input LED is on, and the elevator does not level up, then check the selector and limit switches verifying proper input signals back to the controller.

3.3.2 SET FLOOR DEAD ZONE

The elevator should now be at floor level at the bottom floor. When at floor level the “UL, DL, & DZ” input LED’s should be on. If elevator continually tries to seek floor level by leveling up and down, then adjust valve and selector “dead zone” for proper stop. The selector “dead zone” is increased by moving the selector sensor boards closer together. Proceed to the next step.

3.3.3 ADJUST VALVE

Setup car call, either from the LCD Display Interface or from simulating a pushbutton with jumper wire. The elevator should start up, accelerate to high speed, decelerate when slowdown point is reached, and level into floor. The doors will not open because toggle switches “IND & AD” are still in the down position. Continue to run elevator by setting up car calls. Adjust valve for smooth accel, decel, and final stop in both up and down directions. Proceed to the next step.

3.3.4 ADJUST SAFETY PROCESSOR BOARD SPEED CLAMPS

Make a one floor run to the top floor. The car must reach top speed on a one floor run. After the car stops, record the velocity the car hit the “UT, DT, UTS & DTS” slowdown limits. The velocity value is shown from the LIM VEL menu on the safety processor board LCD display.

The velocity value shown on the display for the “UT or DT” limit is the value after the car hits the limit then counts the adjustable number of counts set from “UT Count” or “DT Count”. When using a tape feedback, there are 16 pulse counts per foot or 1.333 pulses per inch. If the limit is set to 40” from the terminal, to set the checkpoint at 20” use a count value of $(20 * 1.333) = 26.6$. Round up and set the UT and DT count to 27. If the UT or DT Counts are modified, the limit velocity has to be rechecked.

Make a one floor run to the bottom floor and record the limit velocity when the car stops.

Take the speed value for the up or down terminal slowdown limit, add 15 fpm and then set the new value in the corresponding variable from the ADJ VAR menu.

3.3.5 VERIFY INSPECTION VELOCITY CLAMP ON SAFETY PROCESSOR BOARD

With the car on inspection, set the inspection speed on the safety processor board to 25 fpm (Refer to Safety Processor Adjustable Variables in section 6). Set the inspection speed on the main CPU to 50 fpm (Refer to Adjustable Variables in section 5). Run the car in either direction on inspection. The car will shutdown when the speed goes above 25 fpm. Reset the inspection speed on main CPU to the desired inspection speed and set the inspection speed on the Safety Processor to 140 fpm or lower. Make sure the car will run on inspection without shutting down.

3.3.6 ENABLE DOORS

Before proceeding re-check all safety circuits and door lock circuits for proper operation. If all safety circuits and door locks are operating properly then flip the “AD” toggle switch to the up position, and the doors should open and remain open. The elevator is now on independent service. If the doors do not open, then check door operator wiring. Adjust door operator for proper operation. Proceed to the next step.

3.3.7 FINE TUNE RIDE AND STOPS

Run elevator to all floors. “Fine tune” all floor level magnets so that elevator stops level at all floors. Check all signals for proper operation. Flip the “IND” toggle switch to the up position. All four toggle switches should now be in the up position. Elevator doors should close and now be in full automatic operation. Check all hall buttons for proper operation. Proceed to the next step.

3.3.8 FINE TUNE PARAMETERS

Check all field adjustable parameters from the LCD Display Interface and set as desired.

4 TROUBLESHOOTING

4.1 GENERAL INFORMATION

The GALaxy controller is equipped with a number of features that aid in troubleshooting any problems that may occur. The physical layout of the controller provides ready access to all I/O in order to make voltage measurements. All inputs have LED's to monitor the state of the input. The controller is also equipped with an LCD Display interface discussed in sections 5, and an LCD Display interface on the Safety Processor Board discussed in section 6. In this section the basic points of troubleshooting will be detailed.

4.2 MICROPROCESSOR CPU

The CPU is very reliable and normally trouble-free. With power turned on, the "axy" in GALaxy on the LCD Display interface should be blinking at one second intervals to indicate that the CPU is running. If it is not blinking, then check voltage at the 5V terminal with respect to the 0V terminal on the 1010D board. This voltage should read 5VDC. If not, then check the input and output voltage of the DC power supply. If the "axy" is not blinking and 5VDC is present at the 5V terminal with respect to the 0V terminal, then contact the factory.

All job parameters that are not field adjustable are stored in FLASH. All job parameters that are field adjustable are stored in battery backed-up RAM. This battery is designed to back-up the RAM for one year with no power on the system. Under normal operating and maintenance procedures, the battery should last indefinitely. If, however, a battery were to go bad, the field adjustable parameters will return to the default settings when the main power is turned off. To check if the battery voltage is correct, measure the voltage from J17 on the CPU board to 0V on the 1010D board. This voltage should read approximately 3VDC. If not, the CPU board must be repaired by the factory.

4.3 INPUT/OUTPUT BOARDS

The two main sections of all the I/O boards are the low voltage and the high voltage sections. The low voltage section consists of all the digital interfacing necessary for the CPU to communicate with the field components. The high voltage section consists of the field components (buttons, switches, lights, relays and sensors) and their associated input and output signals. The standard voltage for all I/O is 120VAC. However, if necessary, the I/O boards can accept a voltage range from 24V to 120V AC or DC.

It is very important that the wiring schematics are viewed in order to determine the voltages for which the controller was designed before power is applied. The majority of problems that may arise with the control system are due to faulty inputs or outputs on the high voltage side of the system. For example, having a limit switch not feeding or an acknowledgment light out. The GALaxy control system is designed to enable the technician to check both the high voltage section and the low voltage section to correct the problem.

The high voltage section is checked with a digital voltmeter or with the individual LED's that are associated with each input. Depending on the particular input or output, the voltage measured at the terminal will either be "high" or "low" with respect to its reference point. For example, to determine whether or not the up terminal slowdown limit switch was feeding, the voltage should be measured at terminal "UT" with respect to "GND". If the switch is feeding it should read 120VAC. If the switch is open, the voltage should read less than 50VAC. Another means by which to determine whether the switch is feeding is to view the "UT" input LED. If the LED is on, the switch is feeding. If the LED is off, the switch is open.

The previous example determines whether or not the field component is functioning properly. However, to determine if the signal is actually being communicated to the CPU the signal must be checked on the low voltage section of the board. The low voltage section is checked from the 16 diagnostic LED's on the main I/O board or from

the LCD interface. Using the previous example, select the “Inputs and Outputs” menu on the LCD interface. Scroll through the I/O list until “UT” is located. It will show “UT=1” if the “UT” switch is feeding and “UT=0” if the switch is open.

A second example will show how to determine if an output is working properly. With the car at the first floor and the controller designed for 120VAC discrete position indicators, the “P1” output should be on. The voltage measured at terminal “P1” with respect to “GND”, should read 120VAC. If the voltage reads less than 50VAC, the voltage supplied to the output device must be checked. The schematic, in this case, would show the “P1” voltage is supplied at the “PIC” terminal. A voltmeter would be used to measure the voltage between “PIC” and “GND”. If that voltage is at the terminal but the indicator is not on. The LCD interface could be used to view if the CPU is turning the “P1” output on. From the LCD “Inputs and Outputs” menu, scroll through the I/O list until the “P1” is located. The display will show “P1=1” to turn on the “P1” output. For this example, since the CPU is turning on the output and the correct voltage is at the output common but not at the output terminal, it would

indicate that the output solid-state relay for “P1” is defective and should be replaced.

All of the I/O’s are optically isolated between the high voltage section and the low voltage section. The input opto-isolators are socketed IC’s labeled “O_” on the silk screens of the different I/O boards. The output solid-state relays are socketed IC’s labeled “RLY_” on the silk screens of the different I/O boards. If it is determined through the previous troubleshooting procedures that the input signal is present at the terminal, but is not being communicated to the CPU, the input opto-isolator may be defective and can be replaced in the field. If it is determined that the CPU is communicating the output signal to the solid-state relay, but the voltage does not go high at the terminal, the solid-state relay may be defective and can be replaced in the field. Any time IC’s are replaced, the power should be turned off and care should be taken in removal of the old chip and replacement of the new one. All of the I/O and their associated IC’s are listed in the wiring schematics.

4.4 RUN SEQUENCE

The following diagram in figure 4.1 shows the run sequence of the controller.

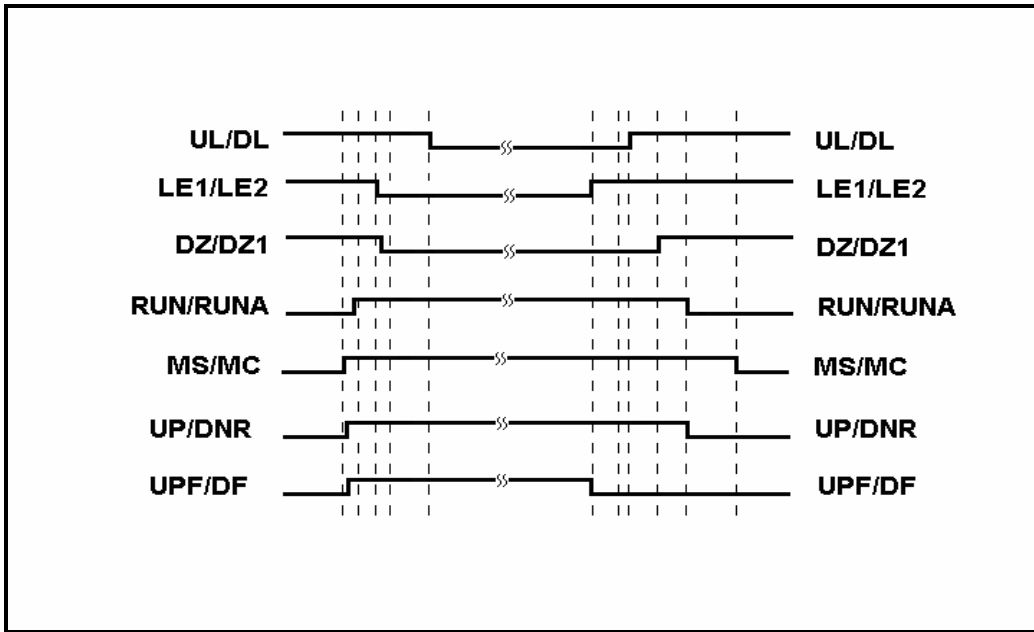

Figure 4.1: Run Sequence.

4.5 THE SAFETY PROCESSOR BOARD

The Safety Processor Board has two fault LED's, one on the top center and one on the bottom center of the board. The top center LED is for PAL inhibit and the bottom center one is for PIC inhibit (see Figure 4.1a).

Important: When either LED is on, this board will prevent the car from running.

The Safety Processor Board verifies the speed of the car when hitting the terminal limits, that the doors are closed when they should be and that the car is safe to run. It also verifies all inspection operations and that the car is not traveling at a speed greater than 150 fpm with a door open in the door zone.

While the Safety Processor Board cannot turn on any run control signals, it can turn off the follow signals from the main CPU: RUNA, UP, DNR, UPF and DF. The SFC relay in the safety string is also controlled by the Safety Processor Board.

The Safety Processor board detects two types of

faults, active faults and velocity faults. Active faults are input conditions that are considered as unsafe or an error such as the lock bypass switch place on while the car is on automatic. Velocity faults are cause by a condition while the car speed is too high such as hitting the DTS terminal limit at a speed greater than the speed setting for that limit. Both type of faults are reset after a 2 second delay, the condition is corrected and the main CPU is not commanding an up or down run.

When troubleshooting errors detected by the Safety Processor board, take the following steps:

- Check LED status. Either PAL inhibit or PIC inhibit LED on indicates an error.
- View the elevator service "Elev Serv". Anything other than Automatic or a valid inspection service is an error.
- View the inputs "Inp/Out" for an incorrect input status. See the Safety Processor LCD Display Interface section for all the input and output signals.

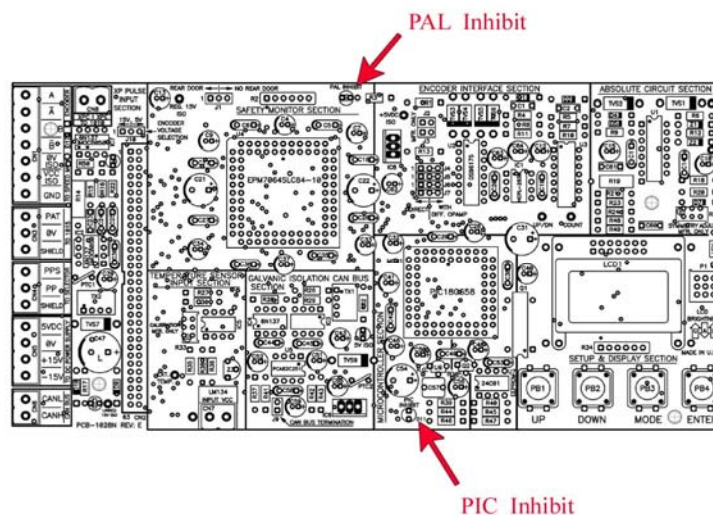

Figure 4.1a: Safety Processor board(1028)

- View the fault log “Faults” for recorded faults. The Safety Processor Board faults are recorded in ram and will be lost when power is turned off.

Of the signals that the Safety Processor Board can turn off, the RUNA is turned on first in a start sequence. Since the Safety Processor and the main CPU run independent of each other, a RUNA Off error on the main CPU is typically caused by the Safety Processor detecting an error at the instant the run is starting. When a RUNA Off error is recorded, check the status of the Safety Processor board first.

During a fault condition when the Safety Processor drops the SFC relay, every input after the SFC terminal will loose voltage including the inputs for

the normal and terminal limits. This could cause an Up or Down directional limit error on the main CPU.

Even though we take every precaution to detect an error and display the appropriate error code, sometimes the sequence of inputs and output change so quickly that correct error is not recorded. Usually the fault table data will lead to the circuit where the error was detected but, in addition, it is also necessary to look ahead of the circuit for possible causes.

Additional fault information is shown in the next section of system faults.

4.6 SYSTEM FAULTS

Fault information is displayed on the LCD display from the “Elevator Status” and the “View Fault

Log” menus on the main CPU. Fault information can also be obtained from the Safety Processor LCD display under the “Fault” menu. Below is a list of system faults logged by the main CPU and possible reasons for each fault.

4.6.1 MAIN CPU FAULTS

Fault	Description	Possible Cause/Suggested Fix
Binary Input Fault	The floor position, read from binary inputs on the selector, does not match the car position.	<ul style="list-style-type: none"> Excessive wear on the selector guides. Preset magnet is missing or misaligned. Faulty hall effect sensor on sensor board. Faulty output on selector driver board. Improper wiring between selector and the Top of Car board (1037 or 1040 board). Faulty BP1, BP2 or BP4 input
Bot Final Limit Flt	Bottom Final Limit Open	<ul style="list-style-type: none"> Car traveled onto the bottom final limit. Faulty wiring of the final limit circuit.
Bottom Door Lock Fault	The Bottom Door Lock failed on while the door was open.	<ul style="list-style-type: none"> Faulty door lock. Door lock not adjusted properly. Jumper placed on door lock circuit. Faulty wiring to DLB input. Faulty DLB and DLB-1 inputs (For this to occur both DLB and DLB-1 inputs must fail on). DOL input failed. Replace DOL input chip. Door operator open limit DOL is not adjusted properly
Brake Drop Fault	Brake failed to drop. The BKS input did not close while stopped.	<ul style="list-style-type: none"> Improper adjustment of brake switch. Brake failed to drop.
Brake Fault Set Gripper	The Rope Gripper was tripped when the brake did not drop. The brake switch adjustable variable can be set to only show the brake drop fault if the brake does not drop.	<ul style="list-style-type: none"> Improper adjustment of brake switch. Brake failed to drop.
Brake Pick Fault	Brake failed to pick. The BKS input did not open during the run.	<ul style="list-style-type: none"> Improper adjustment of brake switch. Brake failed to pick.
BRK CAN Com Error	Brake Board CAN Communication Error.	<ul style="list-style-type: none"> Faulty CAN communication wire connection. Verify proper twisted

<u>Fault</u>	<u>Description</u>	<u>Possible Cause/Suggested Fix</u>
		<p>pair wires to the canh and canl terminals on the brake board.</p> <ul style="list-style-type: none"> Noise on the CAN bus. Verify that the shield wire is connected according to the job print.
BRK I/O Failed Off	The BRK input or output has failed off. The BRK coil is wired through a NO contact of MC, a NO regulator release contact of the drive (DON) and a BRK triac of the controller.	<ul style="list-style-type: none"> Improper wiring of the brake BRK coil. Refer to prints for wire connections. Faulty BRKi input. Replace BRKi input chip on 1038 board. Faulty BRK output. Replace BRK output chip on 1038 board. Fault on 1028 Safety Processor Board. The Safety Processor Board can disable the run control to the BRK output chip. Check if the PIC or PAL inhibit LED turns on when the car attempts to run. Check the elevator service, faults, and inputs/outputs on the Safety Processor Board LCD display.
BRK I/O Failed On	The BRK input or output has failed on.	<ul style="list-style-type: none"> Improper wiring of the brake BRK coil. Refer to prints for wire connections. Faulty BRKi input. Replace BRKi input chip on 1038 board. Faulty BRK output. Replace BRK output chip on 1038 board.
Buffer Switch Fault	Buffer Switch Open	<ul style="list-style-type: none"> Verify that the buffer switch is set and the switch is closed. Faulty wiring on the buffer switch circuit. Car hit the buffer
CAN Bus Off Error	CAN Bus Off Error. The can bus has been inactive for too long a period of time.	<ul style="list-style-type: none"> Faulty CAN bus wiring. Check the CAN bus terminal connections on all boards.
CAN Chip Init Error	CAN Chip Initialization Error. The can chip provides a clock output that is used for the system 10 msec clock. The main CPU continually check the clock setup data and if incorrect will reset the CAN chip and set this error code.	<ul style="list-style-type: none"> Faulty system ground. This error can occur if electrical noise on the system ground causes the CAN chip to reset. Fault 1036 board. Replace the 1036 board.
Car 2 Comm Loss	The group car is not communicating with Car 2.	<ul style="list-style-type: none"> Faulty wiring from R/T+ and R/T- from car to car. Faulty 75176 driver chip on 1036 board. Noise on shield wire. Connect shield

<u>Fault</u>	<u>Description</u>	<u>Possible Cause/Suggested Fix</u>
		<p>only on one end.</p> <ul style="list-style-type: none"> Noise on the communication wires. Run wires in separate conduit.
Car 3 Comm Loss	The group car is not communicating with Car 3.	<ul style="list-style-type: none"> Faulty wiring from R/T+ and R/T- from car to car. Faulty 75176 driver chip on 1036 board. Noise on shield wire. Connect shield only on one end. Noise on the communication wires. Run wires in separate conduit.
Car 4 Comm Loss	The group car is not communicating with Car 4.	<ul style="list-style-type: none"> Faulty wiring from R/T+ and R/T- from car to car. Faulty 75176 driver chip on 1036 board. Noise on shield wire. Connect shield only on one end. Noise on the communication wires. Run wires in separate conduit.
Car 5 Comm Loss	The group car is not communicating with Car 5.	<ul style="list-style-type: none"> Faulty wiring from R/T+ and R/T- from car to car. Faulty 75176 driver chip on 1036 board. Noise on shield wire. Connect shield only on one end. Noise on the communication wires. Run wires in separate conduit.
Car 6 Comm Loss	The group car is not communicating with Car 6	<ul style="list-style-type: none"> Faulty wiring from R/T+ and R/T- from car to car. Faulty 75176 driver chip on 1036 board. Noise on shield wire. Connect shield only on one end. Noise on the communication wires. Run wires in separate conduit.
Car Call Light Fuse	Car Call Light Fuse Blown	<ul style="list-style-type: none"> Check for short on the Car Call Light circuit.
Car Call Power Fuse	Car Call Power Fuse Blown	<ul style="list-style-type: none"> Check for short on Car Call Power circuit.
Car Com Device Reset	Serial Car board reset unexpectedly. Usually caused by loss of power to the individual board.	<ul style="list-style-type: none"> Usually caused by loss of power to the individual board. Check for loose connection on power to board. Faulty I/O board.
Car Safe Fault	The Car Safe Fault occurs from the wanting to run but does not have a critical input energized. Some of the conditions for a car safe fault will also	<ul style="list-style-type: none"> The car does not have the gate or lock inputs and is running or trying to run The gripper GTS input is not on.

<u>Fault</u>	<u>Description</u>	<u>Possible Cause/Suggested Fix</u>
	cause other faults to be logged.	<ul style="list-style-type: none"> • The stop switch is open • An inspection string input fault. Only one input should be on in the inspection string (AUTO, CTI, ICI, ACC or MRI) • Gate or Lock Bypass switch is on when not on car top inspection
Car Safe Fault Preop	The car had a car safe fault while pre-opening the door.	<ul style="list-style-type: none"> • The car lost the DZ input while leveling into the floor and the door was open.
Car Safe Fault Start	The car had an onward call, had the door close limit but the car gate or door locks did not make after a 3 second time-out.	<ul style="list-style-type: none"> • The locks are not making properly when the door closes. • The door is not closing properly.
Car Safety Sw. Flt	Car Safety Switch Fault	<ul style="list-style-type: none"> • Verify that the car safety is not tripped. • Faulty wiring in the car safety circuit.
Comp. Switch Fault	Compensating Rope Switch Open	<ul style="list-style-type: none"> • Verify that the compensating rope switch is set and the switch is closed. • Improper cabling of the compensating ropes on the sheave.
CWT Error at DT	Car “above cwt” flag was set for above the counterweight when the car hit the down terminal slowdown limit.	<ul style="list-style-type: none"> • The counterweight switch was not hit during the run or the car was lost when powered up. • Faulty wiring of the counterweight switch. • Improper adjustment of the counterweight switch.
CWT Error at UT	Car “above cwt” flag was set for below the counterweight when the car hit the up terminal slowdown limit.	<ul style="list-style-type: none"> • The counterweight switch was not hit during the run or the car was lost when powered up. • Faulty wiring of the counterweight switch. • Improper adjustment of the counterweight switch.
DBR Temperature Flt	Dynamic Braking Resistor Temperature Fault. The temperature for the dynamic braking resistors is read in through a temperature sensor mounted above the resistors. The temperature sensor connects to the temperature sensor input board mounted on the DIO1 connector on the CPU board. When the temperature sensor opens a contact, the CPU detects a temperature fault, an error is recorded, the car is shut down at the next floor and the DBC	<ul style="list-style-type: none"> • Faulty Temperature Sensor. If the DB Resistors are not hot, check the temperature sensor input board connected to the CPU board. The input LED should be on when the temperature is okay. If the LED is not on, jump the two terminals on the temperature input board and the LED should go on. If the LED goes on then the Temperature Sensor is bad. Replace the Temperature Sensor. • Faulty Temperature Sensor Input

<u>Fault</u>	<u>Description</u>	<u>Possible Cause/Suggested Fix</u>
	relay is de-energized to open the DB Resistor circuit.	Board. Test the sensor input as above. If the LED does not turn on when the input terminals are jumped together, replace the Temperature Sensor Input Board.
Delta Off Fault	DEL input did not come on at start or went off during a run.	<ul style="list-style-type: none"> • The delta contact did not make on a Y-Delta starter. • The MC contact did not make on an across-the-line starter • The “at speed” contact did not make on an electronic soft-starter. • Faulty DEL input. Replace the DEL input chip.
Delta on Fault	DEL input failed on when it should have been off. This would occur at the start of a run when the I/O's are checked. The input failed on or the contact for the input failed closed.	<ul style="list-style-type: none"> • Faulty DEL input (failed on). Check the input and output status on the LCD interface. • Faulty contact for DEL input failed on. Replace the DEL input chip.
DF I/O Failed Off	The DF input or output has failed off.	<p><u>Traction</u></p> <ul style="list-style-type: none"> • Fault on 1028 Safety Processor Board. The Safety Processor Board can disable the run control to the DF output chip. Check if the PIC or PAL inhibit LED turns on when the car attempts to run. Check the elevator service, faults, and inputs/outputs on the Safety Processor Board LCD display. • Faulty DF/B0 output. Replace the DF/B0 output chip. • Faulty DFi/B0i input. Replace DFi/B0i input chip. • No 24VDC from the drive. Verify the 24VDC between terminals 10 and 12 on the drive. • Incorrect jumper placement on 1038 board. Verify that jumpers on the bottom center of the board are positioned for the correct drive type (DSD or HPV). If necessary move the jumpers to the correct drive type. • RUN, MC or BRK auxiliary contact not making properly. Contact GAL for instructions. <p><u>Hydro</u></p> <ul style="list-style-type: none"> • Fault on 1028 Safety Processor Board. The Safety Processor Board can disable the run control to the

<u>Fault</u>	<u>Description</u>	<u>Possible Cause/Suggested Fix</u>
		<p>SDF output chip. Check if the PIC or PAL inhibit LED turns on when the car attempts to run. Check the elevator service, faults, and inputs/outputs on the Safety Processor Board LCD display.</p> <ul style="list-style-type: none"> • Faulty wiring to the SC common on the 1039 board. • Faulty wiring to the SDF terminal on the 1039 board. • Faulty wiring to the Down Fast valve. • Faulty SDFi input (replace input chip). • Faulty SDF output (replace output chip).
DF I/O Failed On	The DF input or output has failed on.	<p><u>Traction</u></p> <ul style="list-style-type: none"> • Faulty DF or B0 output. Replace the DF or B0 output chip. • Faulty DF_i or B0_i input. Replace DF_i or B0_i input chip. • Incorrect jumper placement on 1038 board. Verify that jumpers on the bottom center of the board are positioned for the correct drive type (DSD or HPV). If necessary move the jumpers to the correct drive type. <p><u>Hydro</u></p> <ul style="list-style-type: none"> • Faulty SDF_i input (replace input chip). • Faulty SDF output (replace output chip).
DLB and DLB-1 Opposite	Input failure on one of the Door Lock Bottom (DLB) inputs.	<ul style="list-style-type: none"> • Faulty DLB or DLB-1 input (replace input chip).
DLM and DLM-1 Opposite	Input failure on one of the Door Lock Middle (DLM) inputs.	<ul style="list-style-type: none"> • Faulty DLM or DLM-1 input (replace input chip).
DLT and DLT-1 Opposite	Input failure on one of the Door Lock Top (DLT) inputs.	<ul style="list-style-type: none"> • Faulty DLT or DLT-1 input (replace input chip).
DNR I/O Failed Off	The DNR input or output has failed off.	<p><u>Traction</u></p> <ul style="list-style-type: none"> • Fault on 1028 Safety Processor Board. The Safety Processor Board can disable the run control to the DNR output chip. Check if the PIC or PAL inhibit LED turns on when the car attempts to run. Check the elevator service, faults, and inputs/outputs on the Safety Processor Board LCD display. • Faulty DNR output. Replace the

<u>Fault</u>	<u>Description</u>	<u>Possible Cause/Suggested Fix</u>
		<p>DNR output chip.</p> <ul style="list-style-type: none"> • Faulty DNRI input. Replace DNRI input chip. • No 24VDC from the drive. Verify the 24VDC between terminals 10 and 12 on the drive. • Incorrect jumper placement on 1038 board. Verify that jumpers on the bottom center of the board are positioned for the correct drive type (DSD or HPV). If necessary move the jumpers to the correct drive type. • RUN, MC or BRK auxiliary contact not making properly. Contact GAL for instructions. <p><u>Hydro</u></p> <ul style="list-style-type: none"> • Faulty wiring to the SC common on the 1039 board. • Faulty wiring to the SD terminal on the 1039 board. • Faulty wiring to the Down valve. • Faulty SDi input (replace input chip). • Faulty SD output (replace output chip).
DNR I/O Failed On	The DNR input or output has failed on.	<p><u>Traction</u></p> <ul style="list-style-type: none"> • Faulty DNR output. Replace the DNR output chip. • Faulty DNRI input. Replace DNRI input chip. • Incorrect jumper placement on 1038 board. Verify that jumpers on the bottom center of the board are positioned for the correct drive type (DSD or HPV). If necessary move the jumpers to the correct drive type. <p><u>Hydro</u></p> <ul style="list-style-type: none"> • Faulty SDi input (replace input chip). • Faulty SD output (replace output chip).
DON I/O Failed Off	The DON input or the drive run relay contact has failed off. The run relay on the drive turns on the DON input (Drive ON) indicating that the regulator is released and the drive is controlling the motor.	<ul style="list-style-type: none"> • Loss of voltage on terminal CS. • MC contact in series with the drive run relay opened. • The drive faulted on start and dropped the run relay. Check the drive fault log. • Faulty run relay on the drive. • Faulty DON input on the controller.

<u>Fault</u>	<u>Description</u>	<u>Possible Cause/Suggested Fix</u>
		<p>Replace the DON input chip.</p> <ul style="list-style-type: none"> • The run relay in the drive is not programmed properly. Check the default drive setup for the Configure C0 parameters.
DON I/O Failed On	The DON input or the drive output has failed on. When the drive is turned off, the run relay on the drive will drop out turning off DON.	<ul style="list-style-type: none"> • Faulty run relay on the drive. • Faulty DON input on the controller. Replace the DON input chip. • The run relay in the drive is not programmed properly. Check the default drive setup for the Configure C0 parameters.
Door Close Fault	The door did not reach the Door Close Limit within the door close protection time.	<ul style="list-style-type: none"> • Door Close Limit (DCL) not adjusted properly. • Faulty Door Close Limit (DCL). Replace DCL input chip. • Trash in door track preventing door from closing.
Door Open Fault	The door did not reach the Door Open Limit within the door open protection time.	<ul style="list-style-type: none"> • Door Open Limit (DOL) not adjusted properly. • Faulty Door Open Limit (DOL). Replace DOL input chip.
Door Zone Fault	<p>Door Zone Fault occurs from the following conditions:</p> <ul style="list-style-type: none"> • The car is not on UL or DL when expected. • The car does not have DZ when expected. • The DZ relay does not drop out while in motion. 	<ul style="list-style-type: none"> • The car does not have DZ when it is expected to be level at the floor. • DZ output on selector board failed on or did not turn on. (Replace DZ output on selector driver board). • One or both of the DZ sensors on the selector sensor board failed. Replace selector sensor board. • DZ input on 1038 board failed on or off. Replace DZ input on 1038 board.
Down Directional Fault	Car unexpectedly hit the Down Normal Limit while running down.	<ul style="list-style-type: none"> • Faulty wiring for the DN limit. • The power common to the limit switches (CS) was lost. Check safety string prior to the CS terminal.
DPM Input Fault	The DPM input fault occurs when door opens and the DPM input did not go off.	<ul style="list-style-type: none"> • DPM switch not setup properly on the door operator. • Faulty DPM input. Replace DPM input chip.
DPM Off/GS or DL On	DPM Off with Gate Switch or Door Lock On. The Door Protection Module input must go on before gate switch or door lock inputs go on.	<ul style="list-style-type: none"> • The DPM switch on the door operator is not setup properly. • There is no DPM input on the door operator. Jump the DPM input to the GS-1 terminal. • Fault DPM input. Replace the DPM

<u>Fault</u>	<u>Description</u>	<u>Possible Cause/Suggested Fix</u>
		input chip.
Drive Com 8259 Error	Drive Communications 8259 Error. This error is used to detect a hardware failure on the controller communications port to the drive.	<ul style="list-style-type: none"> • Hardware failure on the CPU board or 1036 board. If this error occurs, contact G.A.L.
Drive Com Error	Drive Communication Error. The controller and drive are not communicating.	<ul style="list-style-type: none"> • Faulty communications cable connection. Check the drive twisted pairs connected from the drive to the 1036 board. • Noise on the communication cable. Verify that the shield on the communications cable to the drive is connected to earth ground on one end. • Faulty communication chip. Replace the 75176 driver chips on the 1036 board.
Drive Com Int Error	Drive Communications Interrupt Enable Error. This error is used to detect a hardware failure on the controller communications port to the drive.	<ul style="list-style-type: none"> • Hardware failure on the CPU board or 1036 board. If this error occurs, contact G.A.L.
Drive Com Trm Error	Drive Communications Transmit Error. This error is used to detect a hardware failure on the controller communications port to the drive.	<ul style="list-style-type: none"> • Hardware failure on the CPU board or 1036 board. If this error occurs, contact G.A.L.
Drive Com Tx Stop Er	Drive Communications Transmit Stop Error. This error is used to detect a hardware failure on the controller communications port to the drive.	<ul style="list-style-type: none"> • Missing jumper on J7 of the 1036 board (COM1 IRQ6). Install the jumper. • Hardware failure on the CPU board or 1036 board. If this error occurs and the jumper J7 is in place, contact G.A.L.
Drive Com TxEmpty Er	Drive Communications Transmit Empty Error. This error is used to detect a hardware failure on the controller communications port to the drive	<ul style="list-style-type: none"> • Hardware failure on the CPU board or 1036 board. If this error occurs, contact G.A.L.
Drive has Com Error	Drive has a communications error. The controller has received a message from the drive that it has communication receive errors.	<ul style="list-style-type: none"> • Faulty communications cable connection. Check the drive twisted pairs connected from the drive to the 1036 board. • Noise on the communication cable. Verify that the shield on the communications cable to the drive is connected to earth ground on one end. • Faulty communication chip. Replace the 75176 driver chips on the 1036

<u>Fault</u>	<u>Description</u>	<u>Possible Cause/Suggested Fix</u>
		board.
Drive Ready Fault	The drive has a fault	<ul style="list-style-type: none"> • The drive has or had a fault. Check the drive fault log. • Faulty RDY input. (Replace the RDY input).
DT Count Fault	The verification position count for the DT input switch was off by more than 10 inches when the switch was activated.	<ul style="list-style-type: none"> • The car was lost due to a preset error. Check the guides on the selector. Check the fault log for binary preset errors. • The controller has a faulty encoder signal for the pulse count. Check that the car can make long runs without overshooting the floor or stopping short of the floor. • The power common to the limit switches (CS) was lost. Check safety string prior to the CS terminal. • Incorrect counting of pulse counts. Check encoder connection to motor and encoder wiring. • Hoistway not learned properly. Perform a hoistwal learn procedure. • DT switch not adjusted properly. Check at slow speed if switch is breaking, making and then braking again. Switch needs to be closer to the cam.
DT Fail On Fault	DT input Failed On Fault. The car was at the bottom floor and the DTS input was low true (DTS switch made) but the DT input was high (DT not made).	<ul style="list-style-type: none"> • The DTS switch is not wired or the DTS switch is not used. If the DTS switch is not used, jump the DT and DTS inputs together. • The DT did not break at the bottom terminal landing. Adjust or replace the DT switch. • Faulty DT input. Replace the DT input chip.
DT1 Count Fault	The verification position count for the DT1 input switch was off by more than 10 inches when the switch was activated.	<ul style="list-style-type: none"> • The car was lost due to a preset error. Check the guides on the selector. Check the fault log for binary preset errors. • The controller has a faulty encoder signal for the pulse count. Check that the car can make long runs without overshooting the floor or stopping short of the floor. • The power common to the limit switches (CS) was lost. Check safety string prior to the CS terminal.

<u>Fault</u>	<u>Description</u>	<u>Possible Cause/Suggested Fix</u>
		<ul style="list-style-type: none"> • Incorrect counting of pulse counts. Check encoder connection to motor and encoder wiring. • Hoistway not learned properly. Perform a hoistwal learn procedure. • DT1 switch not adjusted properly. Check at slow speed if switch is breaking, making and then braking again. Switch needs to be closer to the cam.
DT2 Count Fault	The verification position count for the DT2 input switch was off by more than 14 inches when the switch was activated.	<ul style="list-style-type: none"> • The car was lost due to a preset error. Check the guides on the selector. Check the fault log for binary preset errors. • The controller has a faulty encoder signal for the pulse count. Check that the car can make long runs without overshooting the floor or stopping short of the floor. • The power common to the limit switches (CS) was lost. Check safety string prior to the CS terminal. • Incorrect counting of pulse counts. Check encoder connection to motor and encoder wiring. • Hoistway not learned properly. Perform a hoistwal learn procedure. • DT2 switch not adjusted properly. Check at slow speed if switch is breaking, making and then braking again. Switch needs to be closer to the cam.
DT3 Count Fault	The verification position count for the DT3 input switch was off by more than 18 inches when the switch was activated.	<ul style="list-style-type: none"> • The car was lost due to a preset error. Check the guides on the selector. Check the fault log for binary preset errors. • The controller has a faulty encoder signal for the pulse count. Check that the car can make long runs without overshooting the floor or stopping short of the floor. • The power common to the limit switches (CS) was lost. Check safety string prior to the CS terminal. • Incorrect counting of pulse counts. Check encoder connection to motor and encoder wiring. • Hoistway not learned properly.

<u>Fault</u>	<u>Description</u>	<u>Possible Cause/Suggested Fix</u>
		<p>Perform a hoistwal learn procedure.</p> <ul style="list-style-type: none"> • DT3 switch not adjusted properly. Check at slow speed if switch is breaking, making and then braking again. Switch needs to be closer to the cam.
DTS Count Fault	Down Terminal Slowdown Limit Count Fault. The verification position count for the DTS input switch was off by more than 10 inches when the switch was activated.	<ul style="list-style-type: none"> • The car was lost due to a preset error. Check the guides on the selector. Check the fault log for binary preset errors. • The controller has a faulty encoder signal for the pulse count. Check that the car can make long runs without overshooting the floor or stopping short of the floor. • The power common to the limit switches (CS) was lost. Check safety string prior to the CS terminal. • Incorrect counting of pulse counts. Check encoder connection to motor and encoder wiring. • Hoistway not learned properly. Perform a hoistwal learn procedure. • DTS switch not adjusted properly. Check at slow speed if switch is breaking, making and then braking again. Switch needs to be closer to the cam.
DTS Fail On Fault	DTS input Failed On Fault. The car was at the bottom floor and the DT input was low true (DT switch made) but the DTS input was high (DTS not made).	<ul style="list-style-type: none"> • The DT switch is not wired or DT input was lost. • The DTS did not break at the bottom terminal landing. Adjust or replace the DTS switch. • Faulty DTS input. Replace the DTS input chip.
Encoder Count Error	Encoder Count Error. An error is announced when the encoder count value is greater than 4 inches in 3 milliseconds.	<ul style="list-style-type: none"> • Faulty encoder connection. Verify the encoder connection to the 1022 encoder isolation board. • Faulty 4I30 encoder board. Replace the 4I30 board. • Faulty 1022 encoder isolation board. Replace the encoder isolation board. • Bus address problem on the PC/104 bus. Contact GAL regarding this fault.
Estop Fault	An emergency stop occurred while moving or attempting to move.	<ul style="list-style-type: none"> • The “P” input did not drop from MC, BRK or RUN contactors being energized.

<u>Fault</u>	<u>Description</u>	<u>Possible Cause/Suggested Fix</u>
		<ul style="list-style-type: none"> • The drive on (DON) input did not energize or dropped out while running. • The BRK contactor did not energize or dropped out while running. • BRKI input did not turn on or dropped out while running. • The DEL contactor did not energize or dropped out while running • The DEL input did not turn on or dropped out while running. • The stop switch was pulled while running. • The car was not safe usually from clipping a door lock. See Car Safe Fault. • The stall protection timer timed-out. • (Hydro only) An emergency power recall was initiated while the car was running up. • The pulse count stopped counting.
Gate Switch Fault	The Gate Switch failed on while the door was open.	<ul style="list-style-type: none"> • Gate switch not adjusted properly. • GS input failed on. Replace GS input on 1039 board.
Gate/Lock Bypass Switch Fault	The gate or lock bypass switch was on while the car was NOT on car top inspection.	<ul style="list-style-type: none"> • Gate or Lock bypass switch on the controller 1038 board is in the on position. • Gate or Lock bypass input failed on. Replace GBP OR LBP input chip on 1038 board.
Governor Switch Flt	Governor Switch Tripped.	<ul style="list-style-type: none"> • Verify that the governor switch is set properly. • Verify that the drive is setup properly and that the car does not overspeed.
Gripper Did Not Pick Fault	The rope gripper did not pick when the GR1 and GR2 relays were energized.	<ul style="list-style-type: none"> • Faulty wiring to the rope gripper. • Faulty GTS switch on rope gripper. Make sure that the switch opens and closes properly when the gripper is energized and dropped. • Faulty GTS input. Replace the GTS input chip.
Gripper Trip Fault	An overspeed or uncontrolled motion caused the rope gripper to trip.	<ul style="list-style-type: none"> • Check if the governor has tripped from. • Make sure that the brake can hold the car.
Group Comm Loss	Car 2 is not communicating with Car 1.	<ul style="list-style-type: none"> • Faulty wiring from TX+/TX- from car to car.

<u>Fault</u>	<u>Description</u>	<u>Possible Cause/Suggested Fix</u>
		<ul style="list-style-type: none"> Faulty 75176 driver chip on the 1036 Comm/Memory board (next to the connector for the group comm). Noise on shield wire. Connect shield only on one end. Noise on the communication wires. Run wires in separate conduit.
GRT1 Input Off Fault	While testing the rope gripper relays, the contacts for GR1R or GR2R did not close or the GRT1 input failed off.	<ul style="list-style-type: none"> Faulty GR1R or GR2R relays. Replace both GR1R and GR2R relays. Faulty GRT1 input. Replace the GRT1 input chip.
GRT1 Input On Fault	While testing the rope gripper relays, the contacts for GR1R or GR2R did not open or the GRT1 input failed on.	<ul style="list-style-type: none"> Faulty GR1R or GR2R relays. Replace both GR1R and GR2R relays. Faulty GRT1 input. Replace the GRT1 input chip.
GRT2 Input Off Fault	While in a door zone the DZ and DZ1 contacts used in the rope gripper circuit were not closed or the GRT2 input failed off.	<ul style="list-style-type: none"> Faulty DZ or DZ1 relays. Replace both DZ and DZ1 relays. Faulty GRT2 input. Replace the GRT2 input chip. Faulty LE or LE1 outputs. When a DZ input is on from the selector DZ output, LE and LE1 outputs control the DZ and DZ1 relays respectively. Replace the LE and LE1 output chips.
GRT2 Input On Fault	The DZ and DZ1 contacts used in the rope gripper circuit did not open during a run or the GRT2 input failed on.	<ul style="list-style-type: none"> Faulty DZ or DZ1 relays. Replace both DZ and DZ1 relays. Faulty GRT2 input. Replace the GRT2 input chip. Faulty LE or LE1 outputs. When a DZ input is on from the selector DZ output, LE and LE1 outputs control the DZ and DZ1 relays respectively. Replace the LE and LE1 output chips.
GS and GS-1 Opposite	Input failure on one of the Gate Switch (GS) inputs.	<ul style="list-style-type: none"> GS or GS-1 input failed on. Replace GS or GS-1 input chip. Check status of input from Input and Output menu on the LCD interface.
Hall Call Light Fuse	Hall Call Light Fuse Blown	<ul style="list-style-type: none"> Check for short on the Hall Call Light circuit.
HC Com Device Reset	Serial Hall Call board reset unexpectedly. Usually caused by loss of power to the individual board.	<ul style="list-style-type: none"> Usually caused by loss of power to the individual board. Faulty power connection to board. Fault hall call board.

Fault	Description	Possible Cause/Suggested Fix
HC Fuse Blown Fault	The HC input is off. No power on HC.	<ul style="list-style-type: none"> • Make sure that the hall call power for each car is in phase. During a power up for car 1 while car 2 is powering the hall call power could cause a momentary short if the hall call power for each car is not in phase. • Short circuit in the hall call lighting circuitry.
Hoistway Learn Fault	Car is on automatic and the hoistway has not been learned.	<ul style="list-style-type: none"> • Hoistway learn procedure needs to be performed. • Faulty ram-flash memory chip.
Inspection Input Fault	More than one input is on in the inspection string. The inspection string condition is also shown on the safety processor.	<ul style="list-style-type: none"> • Faulty Top of Car inspection wiring. Verify voltage on CTA and ICA terminals when car top inspection switch is in the run position. Verify INS input when switch in the inspection position. • Verify that one and only one inspection string inputs is on: AUTO, MRI, INS, ICI and ACC. • Faulty inspection string input: AUTO, MRI, INS, ICI or ACC. Replace faulty input chip
Inspection Up/Dn Sw	An up or down inspection run input was on when first entering into inspection operation. This caused from a faulty inspection up or down switch or from someone holding the up or down run button when placing the car on inspection.	<ul style="list-style-type: none"> • Faulty inspection up or down input: IU, ID, MRIU, MRIU, BAD, BAU, TAD or TAU. Replace faulty input chip. • Faulty inspection wiring keeping an inspection up or down input on. • Placing the car on inspection while holding an up or down run button.
LC Fuse Blown Fault	The LC input is off. No power on LC.	<ul style="list-style-type: none"> • Short from LC to GND.
Low Pressure Fault	Low Oil Pressure Fault. The low oil pressure switch has been activated.	<ul style="list-style-type: none"> • Low oil in the tank. • Faulty LOS input if low oil switch option is being used. Replace the LOS input chip. • Faulty Low Oil Switch. If low oil switch option is being used. Verify the operation of the low oil switch.
LW Calibration Error	Load Weigher Calibration Error. The load weigher attempted to do an automatic calibration and could not be calibrated.	<ul style="list-style-type: none"> • The load weigher device should be re-calibrated according to the manufacturer's instructions.
MCA I/O Failed Off	The MCA input or output has failed off.	<ul style="list-style-type: none"> • Faulty MCAi input chip. Replace input chip. • Faulty MCA output chip. Replace output chip.

Fault	Description	Possible Cause/Suggested Fix
MCA I/O Failed On	The MCA input or output has failed on.	<ul style="list-style-type: none"> Faulty MCAi input chip. Replace input chip. Faulty MCA output chip. Replace output chip.
MCC I/O Failed Off	The MCC input or output has failed off.	<ul style="list-style-type: none"> Faulty MCCi input chip. Replace input chip. Faulty MCC output chip. Replace output chip.
MCC I/O Failed On	The MCC input or output has failed on.	<ul style="list-style-type: none"> Faulty MCCi input chip. Replace input chip. Faulty MCC output chip. Replace output chip.
Middle Door Lock Fault	The Middle Door Lock failed on while the door was open.	<ul style="list-style-type: none"> Faulty door lock. Jumper on door lock circuit. Door lock not adjusted properly. Faulty wiring to DLM input. Faulty DLM and DLM-1 inputs (For this to occur both DLM and DLM-1 inputs must fail on). DOL input failed. Replace DOL input chip. Door operator open limit DOL is not adjusted properly
Overspeed Fault	Car overspeed fault. If the car goes 15% over contract speed the fault will be logged and the car will do an emergency stop.	<ul style="list-style-type: none"> Encoder PPR incorrectly set. Set to match the Drive's Encoder Pulses. Encoder RPM incorrectly set. Set to match the Motor's RPM. The drive is not controlling the hoist machine motor. Check the response setting on the drive.
P input off Fault	The normally closed contacts on MC, BRK or RUN contactors did not drop.	<ul style="list-style-type: none"> Not enough current draw through all three contacts. Place a 10K 3W resistor from the normally closed contact of RUN to GND. Faulty normally closed contacts on MC, BK or RUN. Replace auxiliary contacts.
P Input On Failure	The "P" input did not drop out while the car was running. This input should drop out when MC, BRK and Run contactors are energized.	<ul style="list-style-type: none"> Faulty contactor or auxiliary contacts on MC, BRK, or RUN. Replace auxiliary contacts or entire contactor.
PC/104 Bus Error	PC/104 Bus Error. During two consecutive reads to the encoder board the count value was different.	<ul style="list-style-type: none"> This error detects a hardware error on the PC/104 bus. Contact GAL regarding this error.
Pit Door Switch Flt	Pit Door Switch Open	<ul style="list-style-type: none"> Verify that the pit door switch is closed. Faulty wiring on the pit door switch

<u>Fault</u>	<u>Description</u>	<u>Possible Cause/Suggested Fix</u>
		circuit.
Pit Switch Fault	Pit Switch Input Open	<ul style="list-style-type: none"> • Verify that the pit switch is closed. • Faulty wiring on the pit switch circuit.
Position Fault	The Terminal limits do not match the car position (UT or DT is hit but the car position is not at the top or bottom floor).	<ul style="list-style-type: none"> • Car is out of step from faulty selector inputs. Check that the DZ, UL and DL selector inputs work properly at each floor. • Car missed a slowdown input magnet. Check that the US and DS selector inputs work properly prior to each landing. • UT or DT input lost from the safety string being opened. • Improper adjustment of UT or DT limit switches.
Possible DRV/1028 Er	The controller CPU lost the stop switch input, but has the SS and GTS inputs ON indicating that the drive or Safety Processor (1028) board has opened the safety string.	<ul style="list-style-type: none"> • View the faults on the Safety Processor board display and debug from the fault code listed. • View the drive faults log or led status and debug as directed from the drive manual.
Power Up Reset	Whenever power is cycled on the controller this error will indicate that the controller CPU was reset.	<ul style="list-style-type: none"> • This error code is normal for a power loss. If power was not lost and the CPU re-boots, verify the +5VDC on the CPU power connector reads in the range of 4.90 and 5.1 VDC. If out of range, adjust the 5VDC supply pot for the correct voltage.
Pulse Er 75% Top Speed	Pulse Error occurred while car is running greater then 75% of contract speed. The pulse counts have to change a minimum distance by the time the car reaches 75% of top speed.	<ul style="list-style-type: none"> • This error occurs if the car loses its pulse feedback from the encoder. Make sure that the encoder is not slipping. Check the encoder cable from the drive to the controller. Also check the ribbon cable from the encoder isolation board (1022N) to the encoder board (4I30) on the PC/104 CPU stack. • Possible faulty encoder isolation board (1022N), faulty ribbon cable or faulty encoder board (4I30).
Pulse Error > 75 fpm	Pulse count shows a travel distance less then 2 inches while the car demand velocity is greater than 75 fpm.	<ul style="list-style-type: none"> • Make sure that the encoder is not slipping. Check the ribbon cable from the encoder isolation board (1022N) to the encoder board (4I30) on the PC/104 CPU stack. • Possible faulty encoder isolation board (1022N), faulty ribbon cable or

<u>Fault</u>	<u>Description</u>	<u>Possible Cause/Suggested Fix</u>
		faulty encoder board (4I30).
Rear Bottom Door Lock Fault	The Rear Bottom Door Lock failed on while the door was open (door on the rear door open limit).	<ul style="list-style-type: none"> • Faulty door lock. • Jumper placed on door lock circuit. • Rear door lock not adjusted properly. • Faulty wiring to DLB input. • Faulty DLB and DLB-1 inputs (For this to occur both DLB and DLB-1 inputs must fail on). • DOLR input failed. Replace DOLR input chip. • Rear door operator open limit is not adjusted properly
Rear Door Close Fault	The rear door did not reach the Rear Door Close Limit within the door close protection time.	<ul style="list-style-type: none"> • Rear Door Close Limit (DCLR) not adjusted properly. • Faulty Rear Door Close Limit (DCLR). Replace DCRL input. • Trash in door track preventing door from closing.
Rear Door Open Fault	The rear door did not reach the Rear Door Open Limit within the door open protection time.	<ul style="list-style-type: none"> • Rear Door Open Limit (DOLR) not adjusted properly. • Faulty Rear Door Open Limit (DOLR). Replace DOLR input.
Rear Gate Switch Fault	The Rear Gate Switch failed on while the door was open.	<ul style="list-style-type: none"> • Rear Gate switch not adjusted properly. • RGS input failed on. Replace RGS input.
Rear Middle Door Lock Fault	The Middle Door Lock failed on while the door was open.	<ul style="list-style-type: none"> • Faulty door lock. • Jumper placed on door lock circuit. • Rear door lock not adjusted properly. • Faulty wiring to RLM input. • Faulty RLM and RLM-1 inputs (For this to occur both RLM and RLM-1 inputs must fail on). • DOLR input failed. Replace DOLR input chip. • Rear door operator open limit is not adjusted properly
Rear Top Door Lock Fault	The Rear Top Door Lock failed on while the door was open.	<ul style="list-style-type: none"> • Faulty door lock. • Jumper placed on door lock circuit. • Rear door lock not adjusted properly. • Faulty wiring to DLT input. • Faulty DLT and DLT-1 inputs (For this to occur both DLT and DLT-1 inputs must fail on). • DOLR input failed. Replace DOLR input chip.

<u>Fault</u>	<u>Description</u>	<u>Possible Cause/Suggested Fix</u>
		<ul style="list-style-type: none"> • Rear door operator open limit is not adjusted properly
Reset Fault	<p>Anytime the system detects one of the following faults a reset fault is logged:</p> <ul style="list-style-type: none"> • . Power is cycled • Controller finds itself out of the door zone. • Binary input fault. • Terminal limits do not match the current position. • Car has been switched off of inspection. • After an open safety string has been closed. 	<ul style="list-style-type: none"> • This fault is logged under normal conditions. Check the fault log for error that would indicate a fault condition prior to the reset fault.
RGS and RGS-1 Opposite	Input failure on one of the Rear Gate Switch (RGS) inputs.	<ul style="list-style-type: none"> • Faulty RGS or RGS-1 input. Replace input chip.
RLM and RLM-1 Opposite	Input failure on one of the Rear Lock Middle (RLM) inputs.	<ul style="list-style-type: none"> • Faulty RLM or RLM-1 input. Replace input chip.
RPM Input Fault	RPM Input Fault. The Rear Door Protection input stayed on when the rear door reached full open.	<ul style="list-style-type: none"> • RPM switch not setup properly on the door operator. • Faulty RPM input. Replace RPM input chip.
RPM Off/RGS or RDL On	RPM Off with Rear Gate Switch or Door Lock On. The Rear Door Protection Module input must go on before rear gate switch or door lock inputs go on.	<ul style="list-style-type: none"> • The RPM switch on the door operator is not setup properly. • There is no RPM input on the door operator. Jump the RPM input to the RGS terminal. • Faulty RPM input. Replace the RPM input chip.
Run Fault: Shutdown	<p>Run Fault: Shutdown. If the car attempts to run 4 consecutive times and incurs a specific type of emergency stop without making a successful run, the car is shutdown and this error code is shown. The specific types of emergency stops to cause this fault are as follows:</p> <ol style="list-style-type: none"> 1. The car has picked the brake and is in the run mode for more than 2 seconds and the position pulse has not changed. 2. The car is demanding a velocity greater than 75 fpm and change in position count is less than 3 inches. 3. The run stall protection timer has expired 	<ul style="list-style-type: none"> • Verify that the brake is lifting properly. <ol style="list-style-type: none"> a. Verify that the encoder pulses increment and decrement when running up or down.
RUN I/O Failed	The RUN input or output has failed	<u>Traction</u>

<u>Fault</u>	<u>Description</u>	<u>Possible Cause/Suggested Fix</u>
Off	off.	<ul style="list-style-type: none"> Faulty wiring to RN1 terminal. Faulty RUNi input. Replace the RUNi input chip. Faulty RUN output. Replace the RUN output chip. <u>Hydro</u> <ul style="list-style-type: none"> Faulty wiring at the SC terminal. Verify that the valve common SC terminal on the 1038 board is connected properly. Faulty RUNi input. Replace the RUNi input chip. Faulty RUN output. Replace the RUN output chip.
RUN I/O Failed On	The RUN input or output has failed on.	<u>Traction</u> <ul style="list-style-type: none"> Faulty wiring to RN1 terminal. Faulty RUNi input. Replace the RUNi input chip. Faulty RUN output. Replace the RUN output chip. <u>Hydro</u> <ul style="list-style-type: none"> Faulty wiring at the SC terminal. Verify that the valve common SC terminal on the 1038 board is connected properly. Faulty RUNi input. Replace the RUNi input chip. Faulty RUN output. Replace the RUN output chip.
RUN, RUNA, DNR Failure	The RUN input or output, the RUNA output or the DNR output failed to turn on.	<u>Hydro</u> <ul style="list-style-type: none"> Faulty wiring at the SC terminal. Verify that the valve common SC terminal on the 1038 board is connected properly. Faulty wiring at the SD terminal. Verify that the down valve is wired to the SD terminal on the 1038 board. Faulty SDi input (replace input chip). Faulty SD output (replace output chip). Faulty RUNi input. Replace the RUNi input chip. Faulty RUN output. Replace the RUN output chip.
RUN, RUNA, UP Failure	The RUN input or output, the RUNA output or the UP output failed to run on.	<u>Hydro</u> <ul style="list-style-type: none"> Faulty wiring at the SC terminal. Verify that the valve common SC

<u>Fault</u>	<u>Description</u>	<u>Possible Cause/Suggested Fix</u>
		<p>terminal on the 1038 board is connected properly.</p> <ul style="list-style-type: none"> • Faulty wiring at the SU terminal. Verify that the down valve is wired to the SU terminal on the 1038 board. • Faulty SUI input (replace input chip). • Faulty SU output (replace output chip). • Faulty RUNi input. Replace the RUNi input chip. • Faulty RUN output. Replace the RUN output chip.
RUNA I/O Failed Off	The RUNA input or output has failed off.	<p><u>Traction</u></p> <ul style="list-style-type: none"> • Fault on 1028 Safety Processor Board. The Safety Processor Board can disable the run control to the RUNA output chip. Check if the PIC or PAL inhibit LEDs are on or if they turn on when the car attempts to run. Check the elevator service, faults, and inputs/outputs on the Safety Processor Board LCD display. • Faulty RUNAi input. Replace the RUNAi input chip. • Faulty RUNA output. Replace the RUNA output chip. <p><u>Hydro</u></p> <ul style="list-style-type: none"> • Faulty wiring at the SC terminal. Verify that the valve common SC terminal on the 1038 board is connected properly. • Faulty RUNAi input. Replace RUNAi input chip. • Faulty RUNA output. Replace RUNA output chip. • Faulty RUN output. Replace RUN output chip.
RUNA I/O Failed On	The RUNA input or output has failed on.	<p><u>Traction</u></p> <ul style="list-style-type: none"> • Faulty RUNAi input. Replace the RUNAi input chip. • Faulty RUNA output. Replace the RUNA output chip. <p><u>Hydro</u></p> <ul style="list-style-type: none"> • Faulty wiring at the SC terminal. Verify that the valve common SC terminal on the 1038 board is connected properly. • Faulty RUN output. Replace RUN

<u>Fault</u>	<u>Description</u>	<u>Possible Cause/Suggested Fix</u>
		<p>output chip.</p> <ul style="list-style-type: none"> • Faulty RUNAi input. Replace RUNAi input chip. • Faulty RUNA output. Replace RUNA output chip.
Safety String Fault	<p>Safety string fault occurs from the following conditions:</p> <ul style="list-style-type: none"> • The safety string is open (SS input is off). • The drive ready input is not energized from the drive. • The potential to run input “P” is off. 	<ul style="list-style-type: none"> • The safety string is open (SS input if off). Refer to the job prints and check all circuits ahead of the SS input.
SEB CAN Com Error	Serial Expansion Board CAN Communications Error. One of the Serial Expansion boards is not communicating with the main CPU.	<ul style="list-style-type: none"> • From the LCD user interface, select the Diagnostic menu and then the Car Com Status menu. The device that is not communicating will be shown with the online status equal 0. Check the terminal connection for the twisted pair wires.
Side Emerg. Exit Flt	Side Emergency Exit Fault	<ul style="list-style-type: none"> • Verify that the side emergency exit is properly shut and the switch is closed. • Faulty wiring in the side emergency exit circuit.
SPB CAN Com Error	Safety Processor Board CAN Communications Error. The Safety Processor Board is not communicating to the main CPU.	<ul style="list-style-type: none"> • Check the terminal connection for the twisted pair wires. • Verify that the bus termination jumper is placed on the 1028 Safety Processor Board. • Verify that the bus termination jumper is place on the 1036 Comm/Memory board. • Disconnect the CAN wires to the traveling cable. If the 1028 SPB starts communicating, verify that the bus termination jumper is placed on the TOC board (1037 or 1040). Replace the traveling cable CAN wires.
Stalled Fault	Stall Fault occurs if the motion run timer exceeds the stall protection time. The motion run timer is incremented while the car is trying to run.	<ul style="list-style-type: none"> • Low oil. • Improper valve adjustment.
Stop Switch Fault	Stop switch is pulled while the car is in motion.	<ul style="list-style-type: none"> • Stop switch is pulled. • Faulty wire connection in the stop switch circuit.

Fault	Description	Possible Cause/Suggested Fix
Target Fault at DT	When going down, the target count should always be below the position count. This fault is logged if the target count is above the position count when the DT slowdown limit is hit.	<ul style="list-style-type: none"> This fault should never occur. Please call the factory if this fault occurs.
Target Fault at DT1	This fault is logged if the target count is above the position count when the DT1 slowdown limit is hit	<ul style="list-style-type: none"> This fault should never occur. Please call the factory if this fault occurs.
Target Fault at DT2	This fault is logged if the target count is above the position count when the DT2 slowdown limit is hit.	<ul style="list-style-type: none"> This fault should never occur. Please call the factory if this fault occurs.
Target Fault at DT3	This fault is logged if the target count is above the position count when the DT3 slowdown limit is hit.	<ul style="list-style-type: none"> This fault should never occur. Please call the factory if this fault occurs.
Target Fault at DTS	This fault is logged if the target count is above the position count when the DTS slowdown limit is hit.	<ul style="list-style-type: none"> This fault should never occur. Please call the factory if this fault occurs.
Target Fault at UT	When going up, the target count should always be above the position count. This fault is logged if the target count is below the position count when the UT slowdown limit is hit.	<ul style="list-style-type: none"> This fault should never occur. Please call the factory if this fault occurs.
Target Fault at UT1	This fault is logged if the target count is below the position count when the UT1 slowdown limit is hit.	<ul style="list-style-type: none"> This fault should never occur. Please call the factory if this fault occurs.
Target Fault at UT2	This fault is logged if the target count is below the position count when the UT2 slowdown limit is hit.	<ul style="list-style-type: none"> This fault should never occur. Please call the factory if this fault occurs.
Target Fault at UT3	This fault is logged if the target count is below the position count when the UT3 slowdown limit is hit.	<ul style="list-style-type: none"> This fault should never occur. Please call the factory if this fault occurs.
Target Fault at UTS	This fault is logged if the target count is above the position count when the UTS slowdown limit is hit.	<ul style="list-style-type: none"> This fault should never occur. Please call the factory if this fault occurs.
TOC CAN Com Error	Top of Car Board Communication Error.	<ul style="list-style-type: none"> Fault CAN wire connection. Verify the traveling cable connections from the 1038 Comm/Memory board, to the 1028 Safety Processor board and to the TOC board (1037 or 1040). Jumper for bus termination resistors not placed. Verify that the bus termination resistor jumpers are placed on the TOC (1037 or 1040), on the 1036 Comm/Memory Board, and on the 1028 Safety Processor Board. Noise on the communication cable. Verify that the traveling cable shield wires are connected is connected

<u>Fault</u>	<u>Description</u>	<u>Possible Cause/Suggested Fix</u>
		<p>only at one end or is not connected at all.</p> <ul style="list-style-type: none"> • Faulty communication chip. Replace the CAN bus drive chip 82C251. • Faulty 5V isolated supply for CAN driver on TOC board (1037 or 1040). Measure DC voltage between pins 2 and 3 on the 82C251 CAN driver chip. Call GAL for instructions.
Top Door Lock Fault	The Top Door Lock failed on while the door was open.	<ul style="list-style-type: none"> • Faulty door lock. • Jumper on door lock circuit. • Door lock not adjusted properly. • Faulty wiring to DLT input. • Faulty DLT and DLT-1 inputs (For this to occur both DLT and DLT-1 inputs must fail on). • DOL input failed. Replace DOL input chip. • Door operator open limit DOL is not adjusted properly
Top Emerg. Exit Flt	Top Emergency Exit Fault	<ul style="list-style-type: none"> • Verify that the top emergency exit is properly shut and the switch is closed. • Faulty wiring in the top emergency exit circuit.
Top Final Limit Flt	Top Final Limit Open.	<ul style="list-style-type: none"> • Car traveled onto the top final limit. • Faulty wiring of the final limit circuit.
UL or DL Fault	Both UL and DL level sensors are off when car is at a floor.	<ul style="list-style-type: none"> • Faulty adjustment of the selector head. • Worn selector guides. Replace selector guides. • Faulty Door Zone Magnet. If this fault occurs at one particular floor, replace the door zone magnet at the floor. • Faulty sensor board. Replace the selector sensor board.
Up Directional Fault	Car unexpectedly hit the Up Normal Limit while running up.	<ul style="list-style-type: none"> • Faulty wiring for the UN limit. • The power common to the limit switches (CS) was lost. Check safety string prior to the CS terminal.
UP I/O Failed Off	The UP input or output has failed off.	<p><u>Traction</u></p> <ul style="list-style-type: none"> • Fault on 1028 Safety Processor Board. The Safety Processor Board can disable the run control to the UP output chip. Check if the PIC or PAL inhibit LED turns on when the

<u>Fault</u>	<u>Description</u>	<u>Possible Cause/Suggested Fix</u>
		<p>car attempts to run. Check the elevator service, faults, and inputs/outputs on the Safety Processor Board LCD display.</p> <ul style="list-style-type: none"> • Faulty UP output. Replace the UP output chip. • Faulty UPi input. Replace UPi input chip. • No 24VDC from the drive. Verify the 24VDC between terminals 10 and 12 on the drive. • Incorrect jumper placement on 1038 board. Verify that jumpers on the bottom center of the board are positioned for the correct drive type (DSD or HPV). If necessary move the jumpers to the correct drive type. • RUN or MC auxiliary contact not making properly. Contact GAL for instructions. <p><u>Hydro</u></p> <ul style="list-style-type: none"> • Faulty wiring to the SC common on the 1038 board. • Faulty wiring to the SU terminal on the 1038 board. • Faulty wiring to the Up valve. • Faulty SUi input. Replace SUi input chip. • Faulty SU output. Replace SU output chip).
UP I/O Failed On	The UP input or output has failed on.	<p><u>Traction</u></p> <ul style="list-style-type: none"> • Faulty UP output. Replace the UP output chip. • Faulty UPi input. Replace UPi input chip. • Incorrect jumper placement on 1038 board. Verify that jumpers on the bottom center of the board are positioned for the correct drive type (DSD or HPV). If necessary move the jumpers to the correct drive type. <p><u>Hydro</u></p> <ul style="list-style-type: none"> • Faulty SUi input. Replace SUi, input chip. • Faulty SU output. Replace SU output chip.
UPF I/O Failed Off	The UPF input or output has failed off.	<p><u>Traction</u></p> <ul style="list-style-type: none"> • Fault on 1028 Safety Processor

<u>Fault</u>	<u>Description</u>	<u>Possible Cause/Suggested Fix</u>
		<p>Board. The Safety Processor Board can disable the run control to the UPF/B1 output chip. Check if the PIC or PAL inhibit LED turns on when the car attempts to run. Check the elevator service, faults, and inputs/outputs on the Safety Processor Board LCD display.</p> <ul style="list-style-type: none"> • Faulty UPF/B1 output. Replace the UPF/B1 output chip. • Faulty UPFi/B1i input. Replace UPFi/B1i input chip. • No 24VDC from the drive. Verify the 24VDC between terminals 10 and 12 on the drive. • Incorrect jumper placement on 1038 board. Verify that jumpers on the bottom center of the board are positioned for the correct drive type (DSD or HPV). If necessary move the jumpers to the correct drive type. • RUN, MC or BRK auxiliary contact not making properly. Contact GAL for instructions. <p><u>Hydro</u></p> <ul style="list-style-type: none"> • Fault on 1028 Safety Processor Board. The Safety Processor Board can disable the run control to the UPF output chip. Check if the PIC or PAL inhibit LED turns on when the car attempts to run. Check the elevator service, faults, and inputs/outputs on the Safety Processor Board LCD display. • Faulty wiring to the SC common on the 1038 board. • Faulty wiring to the SUF terminal on the 1038 board. • Faulty wiring to the Up Fast valve. • Faulty SUFi input. Replace SUFi input chip. • Faulty SUF output. Replace SUF output chip.
UPF I/O Failed On	The UPF input or output has failed on.	<p><u>Traction</u></p> <ul style="list-style-type: none"> • Faulty UPF/B1 output. Replace the UPF/B1 output chip. • Faulty UPFi/B1i input. Replace UPFi/B1i input chip.

<u>Fault</u>	<u>Description</u>	<u>Possible Cause/Suggested Fix</u>
		<ul style="list-style-type: none"> • Incorrect jumper placement on 1038 board. Verify that jumpers on the bottom center of the board are positioned for the correct drive type (DSD or HPV). If necessary move the jumpers to the correct drive type. <p><u>Hydro</u></p> <ul style="list-style-type: none"> • Faulty SUFi input. Replace SUFi input chip. • Faulty SUF output. Replace SUF output chip.
UT Count Fault	The verification position count for the UT input switch was off by more than 10 inches when the switch was activated. The car was lost due to a preset error or the controller has a faulty encoder signal for the pulse count.	<ul style="list-style-type: none"> • The car was lost due to a preset error. Check the guides on the selector. Check the fault log for binary preset errors. • The controller has a faulty encoder signal for the pulse count. Check that the car can make long runs without overshooting the floor or stopping short of the floor. • The power common to the limit switches (CS) was lost. Check safety string prior to the CS terminal. • Incorrect counting of pulse counts. Check encoder connection to motor and encoder wiring. • Hoistway not learned properly. Perform a hoistwal learn procedure. • UT switch not adjusted properly. Check at slow speed if switch is breaking, making and then braking again. Switch needs to be closer to the cam.
UT Fail On Fault	UT input Failed On Fault. The car was at the top floor and the UTS input was low true (UTS switch made) but the UT input was high (UT not made).	<ul style="list-style-type: none"> • The UTS switch is not wired or the UTS switch is not used. If the UTS switch is not used, jump the UT and UTS inputs together. • The UT did not break at the bottom terminal landing. Adjust or replace the UT switch.
UT1 Count Fault	The verification position count for the UT1 input switch was off by more than 10 inches when the switch was activated. The car was lost due to a preset error or the controller has a faulty encoder signal for the pulse count.	<ul style="list-style-type: none"> • The car was lost due to a preset error. Check the guides on the selector. Check the fault log for binary preset errors. • The controller has a faulty encoder signal for the pulse count. Check that the car can make long runs without overshooting the floor or

<u>Fault</u>	<u>Description</u>	<u>Possible Cause/Suggested Fix</u>
		<p>stopping short of the floor.</p> <ul style="list-style-type: none"> • The power common to the limit switches (CS) was lost. Check safety string prior to the CS terminal. • Incorrect counting of pulse counts. Check encoder connection to motor and encoder wiring. • Hoistway not learned properly. Perform a hoistwal learn procedure. • UT1 switch not adjusted properly. Check at slow speed if switch is breaking, making and then braking again. Switch needs to be closer to the cam.
UT2 Count Fault	<p>The verification position count for the UT2 input switch was off by more than 14 inches when the switch was activated. The car was lost due to a preset error or the controller has a faulty encoder signal for the pulse count.</p>	<ul style="list-style-type: none"> • The car was lost due to a preset error. Check the guides on the selector. Check the fault log for binary preset errors. • The controller has a faulty encoder signal for the pulse count. Check that the car can make long runs without overshooting the floor or stopping short of the floor. • The power common to the limit switches (CS) was lost. Check safety string prior to the CS terminal. • Incorrect counting of pulse counts. Check encoder connection to motor and encoder wiring. • Hoistway not learned properly. Perform a hoistwal learn procedure. • UT2 switch not adjusted properly. Check at slow speed if switch is breaking, making and then braking again. Switch needs to be closer to the cam.
UT3 Count Fault	<p>The verification position count for the UT3 input switch was off by more than 18 inches when the switch was activated. The car was lost due to a preset error or the controller has a faulty encoder signal for the pulse count.</p>	<ul style="list-style-type: none"> • The car was lost due to a preset error. Check the guides on the selector. Check the fault log for binary preset errors. • The controller has a faulty encoder signal for the pulse count. Check that the car can make long runs without overshooting the floor or stopping short of the floor. • The power common to the limit switches (CS) was lost. Check safety string prior to the CS terminal.

<u>Fault</u>	<u>Description</u>	<u>Possible Cause/Suggested Fix</u>
		<ul style="list-style-type: none"> • Incorrect counting of pulse counts. Check encoder connection to motor and encoder wiring. • Hoistway not learned properly. Perform a hoistwal learn procedure. • UT3 switch not adjusted properly. Check at slow speed if switch is breaking, making and then braking again. Switch needs to be closer to the cam.
UTS Count Fault	Up Terminal Slowdown Limit Count Fault. The verification position count for the UTS input switch was off by more than 10 inches when the switch was activated. The car was lost due to a preset error or the controller has a faulty encoder signal for the pulse count.	<ul style="list-style-type: none"> • The car was lost due to a preset error. Check the guides on the selector. Check the fault log for binary preset errors. • The controller has a faulty encoder signal for the pulse count. Check that the car can make long runs without overshooting the floor or stopping short of the floor. • The power common to the limit switches (CS) was lost. Check safety string prior to the CS terminal. • Incorrect counting of pulse counts. Check encoder connection to motor and encoder wiring. • Hoistway not learned properly. Perform a hoistwal learn procedure. • UTS switch not adjusted properly. Check at slow speed if switch is breaking, making and then braking again. Switch needs to be closer to the cam.
UTS Fail On Fault	UTS input Failed On Fault. The car was at the top floor and the UT input was low true (UT switch made) but the UTS input was high (UTS not made).	<ul style="list-style-type: none"> • The UT switch is not wired or UT input was lost. • The UTS did not break at the bottom terminal landing. Adjust or replace the UTS switch.
Wrong Dir Pls Run Dn	Wrong Direction Pulses while car running down. The pulse counts should be counting down while the car is running down.	<ul style="list-style-type: none"> • Check the jumper on the encoder isolation board. If this car has been previously running properly, the encoder isolation board could be faulty. If during initial setup, change the jumpers for A and A not.
Wrong Dir Pls Run Up	Wrong Direction Pulses while car running up. The pulse counts should be counting up while the car is running up.	<ul style="list-style-type: none"> • Check the jumper on the encoder isolation board. If this car has been previously running properly, the encoder isolation board could be faulty. If during initial setup, change

<u>Fault</u>	<u>Description</u>	<u>Possible Cause/Suggested Fix</u>
		the jumpers for A and A not.
Zero Vel Decel Roll	Zero Velocity Deceleration Roll. The controller calculated a velocity value of zero during the roll in to constant deceleration.	<ul style="list-style-type: none"> • This fault should never occur. Please call the factory if this fault occurs.

4.6.2 DETAILED FAULT DATA

Detailed Fault Data	Description
SRV	Service Flag 0 = Out of Service 1 = Automatic 2 = Independent 3 = Load Weighing Bypass 4 = Attendant 5 = Code Blue 6 = Fire Phase 2 7 = Emergency Power 8 = Earthquake Emergency 9 = Fire Phase 1 Main Egress 10 = Fire Phase 1 Alternate Egress 11 = Homing 12 = Reset Run Up 13 = Reset Run Down 14 = Low Oil Operation 15 Return to Lobby 16 Load Overload 17 Massachusetts Medical Emergency
PRC	Process Flag 1 = Reset 2 = Inspection 3 = Motion: hsf=1, dir=1, Up Fast hsf=0, dir=1, ul=0, Up Transition hsf=0, dir=1, ul=1, Up Leveling hsf=1, dir=2, Down Fast hsf=0, dir=2, dl=0, Down Transition hsf=0, dir=2, dl=1, Down Leveling 4 = Motion Mode 1 – Soft Start 5 = Motion Mode 2 – Constant Acceleration 6 = Motion Mode 3 – Roll Over to Max Velocity 7 = Motion Mode 4 – Constant Velocity 8 = Motion Mode 5 – Roll Over to Deceleration 9 = Motion Mode 6 – Constant Deceleration 10 = Motion Mode 7 – Targeting Floor 11 = Motion Mode 8 – Emergency Slowdown 12 = Safety String 13 = Turned Off 14 = Parked 15 = Waiting Assignment 16 = Doors Operation 17 = Elevator Stalled (or Low Oil for Hydro)
DRF	Front Door Flag 0 = Door Closed 1 = Door Opening 2 = Door Dwelling 3 = Door Closing 4 = Door Nudging Closed
RDF	Rear Door Flag 0 = Door Closed 1 = Door Opening

Detailed Fault Data	Description
	2 = Door Dwelling 3 = Door Closing 4 = Door Nudging Closed
DPR	Direction Preference Flag 0 = None 1 = Up 2 = Down
DIR	Car Direction Flag 0 = None 1 = Up 2 = Down
EMP	Emergency Power Flag 0 = Not on Emergency Power 1 = On Emergency Power Waiting 2 = On Emergency Power Waiting with Doors Open 3 = On Emergency Power Returning Home 4 = On Em. Power Returned Home with Doors Open 5 = On Em. Power Returned Home with Doors Closed 6 = On Emergency Power and Selected to Run
MED	Medical Emergency 0 = No Medical Emergency Service 1 = Recall Car to Medical Emergency Recall Floor 2 = At Return Floor with Door Open (Return Complete) 4 = On EMS Car Call Service 5 = On EMS Car Hold Service (key off but not at the recall floor)
CBL	Code Blue Flag 0 = No Code Blue 1 = Recall to Emergency Gloor 2 = At Code Blue Floor 3 = At Code Blue Floor with Door Open 4 = finished Code Blue
EQU	Earthquake Flag 0 = Not on Earthquake Operation 1 = Earthquake Sensor Activated 2 = Counterweight Derailment Sensor Activated 3 = Recover Away From the Counterweight 4 = Stopped at a Floor
FIR	Fire Flag 0 = Not on Fire Service 1 = Phase 1 Main Egress Return 2 = Phase 1 Alternate Egress Return 3 = Phase 1 Completed 4 = Phase 2 Door Hold 5 = Phase 2 Constant Pressure Door Open 6 = Phase 2 Constant Pressure Door Close 7 = Phase 2 Door Hold 8 = Phase 2 Momentary DCB Door Close
RFI	Rear Fire Flag 0 = Not on Fire Service 1 = Phase 1 Main Rear Egress Return 2 = Phase 1 Alternate Rear Egress Return 3 = Phase 1 Completed 4 = Phase 2 Rear Door Hold 5 = Phase 2 Constant Pressure Rear Door Open 6 = Phase 2 Constant Pressure Rear Door Close 7 = Phase 2 Rear Door Hold 8 = Phase 2 Momentary DCB Rear Door Close
HSF	High Speed Flag 1 = High Speed
STF	Start Flag 1 = Start of Run
CAL	Direction of Calls 0 = No Call 1 = Above Call

Detailed Fault Data	Description										
	2 = Below Call 3 = Above and Below Calls										
ESP	Emergency Stop Flag 1 = Emergency Stop										
NST	Need to Stop Flag 1 = Car need to stop at next floor										
RLV	Re-level Flag 1 = Car in re-leveling										
STE	Step Flag 1 = Step to the next position (non-distance feedback)										
PDO	Pre-open Door Flag 1 = Pre-open door										
ST0	Next Stop Floor Floor number of next stop										
INS	Inspection Status Flag (Status bit set to "1" when switch is on) Bit 0: Car Top Inspection Bit 1: Machine Room Inspection Bit 2: Access Bit 3: Lock Bypass Bit 4: Gate Bypass Bit 5: Automatic										
NDS	Next Car Up Sequence 0 = Initiate Next Up Door Open 1 = Opening Next Up Door 2 = Door full open on Next Up 3 = Allow door close for onward call 4 = Allow door close while on next up										
GTM	Group Transmitter Empty 1 = Transmit Buffer Empty										
IO0	1038 I/O Block 1, Byte 0: Listed in order of Bits 0-7 <table border="1" style="margin-left: auto; margin-right: auto;"> <thead> <tr> <th>1038 Main I/O</th> </tr> <tr> <th>Block 1</th> </tr> </thead> <tbody> <tr><td>DN</td></tr> <tr><td>DT</td></tr> <tr><td>DTS</td></tr> <tr><td>DT1</td></tr> <tr><td>DT2</td></tr> <tr><td>DT3</td></tr> <tr><td>UN</td></tr> <tr><td>UT</td></tr> </tbody> </table>	1038 Main I/O	Block 1	DN	DT	DTS	DT1	DT2	DT3	UN	UT
1038 Main I/O											
Block 1											
DN											
DT											
DTS											
DT1											
DT2											
DT3											
UN											
UT											
IO1	1038 I/O Block 1, Byte 1: Listed in order of Bits 0-7 <table border="1" style="margin-left: auto; margin-right: auto;"> <thead> <tr> <th>1038 Main I/O</th> </tr> <tr> <th>Block 1</th> </tr> </thead> <tbody> <tr><td>UTS</td></tr> <tr><td>UT1</td></tr> <tr><td>UT2</td></tr> <tr><td>UT3</td></tr> <tr><td>DLB</td></tr> <tr><td>DLM</td></tr> <tr><td>DLT</td></tr> <tr><td>RLM</td></tr> </tbody> </table>	1038 Main I/O	Block 1	UTS	UT1	UT2	UT3	DLB	DLM	DLT	RLM
1038 Main I/O											
Block 1											
UTS											
UT1											
UT2											
UT3											
DLB											
DLM											
DLT											
RLM											
IO2	1038 I/O Block 1, Byte 2: Listed in order of Bits 0-7 <table border="1" style="margin-left: auto; margin-right: auto;"> <thead> <tr> <th>1038 Main I/O</th> </tr> <tr> <th>Block 1</th> </tr> </thead> <tbody> <tr><td>DLB-1</td></tr> <tr><td>DLM-1</td></tr> <tr><td>DLT-1</td></tr> <tr><td>RLM-1</td></tr> <tr><td>ACC</td></tr> <tr><td>BAD</td></tr> <tr><td>BAU</td></tr> </tbody> </table>	1038 Main I/O	Block 1	DLB-1	DLM-1	DLT-1	RLM-1	ACC	BAD	BAU	
1038 Main I/O											
Block 1											
DLB-1											
DLM-1											
DLT-1											
RLM-1											
ACC											
BAD											
BAU											

Detailed Fault Data	Description										
	<table border="1" data-bbox="727 132 925 163"> <tr> <td>TAD</td> </tr> </table>	TAD									
TAD											
IO3	<p>1038 I/O Block 2, Byte 1: Listed in order of Bits 0-7</p> <table border="1" data-bbox="727 296 925 558"> <tr> <td>1039 Main I/O</td> </tr> <tr> <td>Block 2</td> </tr> <tr> <td>HWS</td> </tr> <tr> <td>MRS</td> </tr> <tr> <td>MES</td> </tr> <tr> <td>ALT</td> </tr> <tr> <td>BP</td> </tr> <tr> <td>FS</td> </tr> <tr> <td>HC</td> </tr> <tr> <td>SS</td> </tr> </table>	1039 Main I/O	Block 2	HWS	MRS	MES	ALT	BP	FS	HC	SS
1039 Main I/O											
Block 2											
HWS											
MRS											
MES											
ALT											
BP											
FS											
HC											
SS											
IO4	<p>1038 I/O Block 2, Byte 2: Listed in order of Bits 0-7</p> <table border="1" data-bbox="727 690 925 953"> <tr> <td>1010 Main I/O</td> </tr> <tr> <td>Block 2</td> </tr> <tr> <td>UT4/1U</td> </tr> <tr> <td>UT5/2U</td> </tr> <tr> <td>RTL/3U</td> </tr> <tr> <td>Reserved/4U</td> </tr> <tr> <td>DT4/2D</td> </tr> <tr> <td>DT5/3D</td> </tr> <tr> <td>Spare/4D</td> </tr> <tr> <td>Reserved/5D</td> </tr> </table>	1010 Main I/O	Block 2	UT4/1U	UT5/2U	RTL/3U	Reserved/4U	DT4/2D	DT5/3D	Spare/4D	Reserved/5D
1010 Main I/O											
Block 2											
UT4/1U											
UT5/2U											
RTL/3U											
Reserved/4U											
DT4/2D											
DT5/3D											
Spare/4D											
Reserved/5D											
IO5	<p>1038 I/O Block 3, Byte 0: Listed in order of Bits 0-7</p> <table border="1" data-bbox="727 1085 925 1348"> <tr> <td>1038 Main I/O</td> </tr> <tr> <td>Block 3</td> </tr> <tr> <td>GBP</td> </tr> <tr> <td>LBP</td> </tr> <tr> <td>IND</td> </tr> <tr> <td>AD</td> </tr> <tr> <td>DEL</td> </tr> <tr> <td>BKS</td> </tr> <tr> <td>UL-1</td> </tr> <tr> <td>DL-1</td> </tr> </table>	1038 Main I/O	Block 3	GBP	LBP	IND	AD	DEL	BKS	UL-1	DL-1
1038 Main I/O											
Block 3											
GBP											
LBP											
IND											
AD											
DEL											
BKS											
UL-1											
DL-1											
IO6	<p>1038 I/O Block 3, Byte 1: Listed in order of Bits 0-7</p> <table border="1" data-bbox="727 1480 925 1743"> <tr> <td>1038 Main I/O</td> </tr> <tr> <td>Block 3</td> </tr> <tr> <td>UL</td> </tr> <tr> <td>DZ</td> </tr> <tr> <td>DL</td> </tr> <tr> <td>DPM</td> </tr> <tr> <td>GS</td> </tr> <tr> <td>GS-1</td> </tr> <tr> <td>LC</td> </tr> <tr> <td>INS</td> </tr> </table>	1038 Main I/O	Block 3	UL	DZ	DL	DPM	GS	GS-1	LC	INS
1038 Main I/O											
Block 3											
UL											
DZ											
DL											
DPM											
GS											
GS-1											
LC											
INS											
IO7	<p>1038 I/O Block 4, Byte 0: Listed in order of Bits 0-7</p> <table border="1" data-bbox="727 1875 925 1913"> <tr> <td>1038 Main I/O</td> </tr> </table>	1038 Main I/O									
1038 Main I/O											

Detailed Fault Data	Description										
	<table border="1"> <tr><td>Block 4</td></tr> <tr><td>IU</td></tr> <tr><td>ID</td></tr> <tr><td>CS</td></tr> <tr><td>ICI</td></tr> <tr><td>MRI</td></tr> <tr><td>MRIU</td></tr> <tr><td>MRID</td></tr> <tr><td>AUTO</td></tr> </table>	Block 4	IU	ID	CS	ICI	MRI	MRIU	MRID	AUTO	
Block 4											
IU											
ID											
CS											
ICI											
MRI											
MRIU											
MRID											
AUTO											
IO8	<p>1038 I/O Block 4, Byte 1: Listed in order of Bits 0-7</p> <table border="1"> <tr><td>1038 Board</td></tr> <tr><td>Block 4</td></tr> <tr><td>P/RTL</td></tr> <tr><td>FST</td></tr> <tr><td>GTS</td></tr> <tr><td>RDY</td></tr> <tr><td>GRT1</td></tr> <tr><td>GRT2</td></tr> <tr><td>BRKI</td></tr> <tr><td>DON</td></tr> </table>	1038 Board	Block 4	P/RTL	FST	GTS	RDY	GRT1	GRT2	BRKI	DON
1038 Board											
Block 4											
P/RTL											
FST											
GTS											
RDY											
GRT1											
GRT2											
BRKI											
DON											
IO9	<p>1038 I/O Block 5, Byte 0: Listed in order of Bits 0-7</p> <table border="1"> <tr><td>1038 Board</td></tr> <tr><td>Block 5</td></tr> <tr><td>RUNI</td></tr> <tr><td>RUNAI</td></tr> <tr><td>MCCI</td></tr> <tr><td>MCAI</td></tr> <tr><td>RGS</td></tr> <tr><td>RGS-1</td></tr> <tr><td>SECF/SVSD</td></tr> <tr><td>LVC</td></tr> </table>	1038 Board	Block 5	RUNI	RUNAI	MCCI	MCAI	RGS	RGS-1	SECF/SVSD	LVC
1038 Board											
Block 5											
RUNI											
RUNAI											
MCCI											
MCAI											
RGS											
RGS-1											
SECF/SVSD											
LVC											
IOA	<p>1038 I/O Block 5, Byte 1: Listed in order of Bits 0-7</p> <table border="1"> <tr><td>1038 Board</td></tr> <tr><td>Block 5</td></tr> <tr><td>DNI</td></tr> <tr><td>DFI</td></tr> <tr><td>UPI</td></tr> <tr><td>UFI</td></tr> <tr><td>CWS</td></tr> <tr><td>RDPM</td></tr> <tr><td>GOV</td></tr> <tr><td>PS</td></tr> </table>	1038 Board	Block 5	DNI	DFI	UPI	UFI	CWS	RDPM	GOV	PS
1038 Board											
Block 5											
DNI											
DFI											
UPI											
UFI											
CWS											
RDPM											
GOV											
PS											
IOB	<p>1037/1049 I/O Block 25, Byte 0: Listed in order of Bits 0-7</p> <table border="1"> <tr><td>1037/1040 Board</td></tr> <tr><td>Block 25</td></tr> <tr><td>DOL</td></tr> <tr><td>DCL</td></tr> <tr><td>EE</td></tr> <tr><td>SE</td></tr> <tr><td>LWA</td></tr> <tr><td>OVL</td></tr> <tr><td>LWB</td></tr> </table>	1037/1040 Board	Block 25	DOL	DCL	EE	SE	LWA	OVL	LWB	
1037/1040 Board											
Block 25											
DOL											
DCL											
EE											
SE											
LWA											
OVL											
LWB											

Detailed Fault Data	Description																				
	LWD																				
IOC	1037/1040 I/O Block 25, Byte 1: Listed in order of Bits 0-7 <table border="1"> <thead> <tr> <th>1037/1040 Board</th> </tr> <tr> <th>Block 25</th> </tr> </thead> <tbody> <tr><td>BP1</td></tr> <tr><td>BP2</td></tr> <tr><td>BP4</td></tr> <tr><td>BP8</td></tr> <tr><td>BP16</td></tr> <tr><td>EP</td></tr> <tr><td>US</td></tr> <tr><td>DS</td></tr> </tbody> </table>	1037/1040 Board	Block 25	BP1	BP2	BP4	BP8	BP16	EP	US	DS										
1037/1040 Board																					
Block 25																					
BP1																					
BP2																					
BP4																					
BP8																					
BP16																					
EP																					
US																					
DS																					
IOD	1037/1040 I/O Block 25, Byte 2: Listed in order of Bits 0-7 <table border="1"> <thead> <tr> <th>1037 Board</th> <th>1040 Board</th> </tr> <tr> <th>Block 25</th> <th>Block 25</th> </tr> </thead> <tbody> <tr><td>DO</td><td>DO</td></tr> <tr><td>DC</td><td>DC</td></tr> <tr><td>NUD</td><td>NUD</td></tr> <tr><td>CUL</td><td>P6</td></tr> <tr><td>CDL</td><td>EQL</td></tr> <tr><td>FL</td><td>EML</td></tr> <tr><td>FB/NB</td><td>OLL</td></tr> <tr><td>HB</td><td>CLF</td></tr> </tbody> </table>	1037 Board	1040 Board	Block 25	Block 25	DO	DO	DC	DC	NUD	NUD	CUL	P6	CDL	EQL	FL	EML	FB/NB	OLL	HB	CLF
1037 Board	1040 Board																				
Block 25	Block 25																				
DO	DO																				
DC	DC																				
NUD	NUD																				
CUL	P6																				
CDL	EQL																				
FL	EML																				
FB/NB	OLL																				
HB	CLF																				
STATUSF	Control Status Flag (Status bit set to “1” when status active) Bit 0: NO LC power Bit 1: NO HC power Bit 2: NO SS input Bit 3: Drive not ready Bit 4: Gripper error Bit 5: I/O error during redundancy check Bit 6: Inspection or lock bypass fault Bit 7: Binary Position Input Error Bit 8: Position Error Bit 9: No automatic Doors Bit 10: Stop switch open Bit 11: Door Zone fault Bit 12: Gate or Door lock fault Bit 13: No Potential “P” Input Bit 14: No DCL Bit 15: No gate or lock Bit 16: Brake lift switch error Bit 17: Top of Car Communications Error Bit 18: Drive Communications Error Bit 19: Safety Processor Board Communications Error Bit 20: DB Resistor Temp. Error																				
CT	Position Count in pulses																				
TG	Target Count in pulses																				
VEL	Velocity in feet per minute																				

Detailed Fault Data	Description
ENC VEL	Encoder Velocity in feet per minute

4.6.3 SAFETY PROCESSOR FAULTS

	DESCRIPTION AND CAUSE
No Flt	No fault is recorded in this index location.
Invalid	Invalid fault number. (This can only be caused by a programming error in the chip).
EEprom	EEprom fault. Defective EEprom device or EEprom device is not installed. The car will not be able to run until the EEprom is installed or replaced.
UTS Sp	UTS Speed Fault. The car hit the UTS limit at a higher velocity than the value set for the UTS Velocity adjustable variable. The car will immediately shut down.
DTS Sp	DTS Speed Fault. The car hit the DTS limit at a higher velocity than the value set for the DTS Velocity adjustable variable. The car will immediately shut down.
UT Spd	UT Speed Fault. The car hit the UT limit at a higher velocity than the value set for the UT Velocity adjustable variable. The car will immediately shut down.
DT Spd	DT Speed Fault. The car hit the DT limit at a higher velocity than the value set for the DT Velocity adjustable variable. The car will immediately shut down.
INS Sp	Inspection Speed Fault. The car exceeded the INS Velocity adjustable variable while running on inspection. The car will immediately shut down.
LEV Sp	Leveling Speed Fault. The car exceeded the LEV Velocity adjustable variable while leveling with a door open. The car will immediately shut down.
DL/GS	Door Lock/Gate Switch Fault. Car is moving outside the door zone with the door open. The car will immediately shut down.
IO Flt	I/O Fault. An input is on in error. The Elev Serv display will show the I/O error. Possible causes are as follows: <ul style="list-style-type: none"> 1. All inspection inputs and the auto input are off.

	DESCRIPTION AND CAUSE
	<ol style="list-style-type: none"> 2. More than one inspection or auto input is on at the same time. 3. A bypass input is on while the car is not on Car top inspection. 4. Both up and down run output from the main CPU are on at the same time. <p>The car will not be able to run until the error is cleared.</p>
INS DO	<p>Inspection Door Open Fault. A door is open while running on inspection and the gate and locks are not being bypassed. The car will immediately shut down.</p>
Pls Er	<p>Pulse Error. Not enough pulses have occurred during the Pulse Fault Time period. This error is detected only on automatic operation. Verify that the pulse LED on the Safety Processor board blinks while the car is running on inspection. Possible causes are as follows:</p> <ol style="list-style-type: none"> 1. Improper connection for PP and PPS. Refer to the job specific prints. 2. PP and PPS field wires need to be swapped. 3. Photocoupler in selector is faulty. Call the Factory. 4. Voltage from PP to 0V on the Safety Processor Board is less than 10 VDC with the PP and PPS wires disconnected. Call the Factory.

5 LCD DISPLAY INTERFACE

5.1 OPERATING THE LCD INTERFACE

The LCD display interface board uses a 2 line by 24 character display and four buttons. This interface

allows the user to adjust parameters, view critical controller information, to implement the controller setup and to view the elevator status. Upon power-up the display shows a blinking GALaxy name to indicate the controller is running as show below:

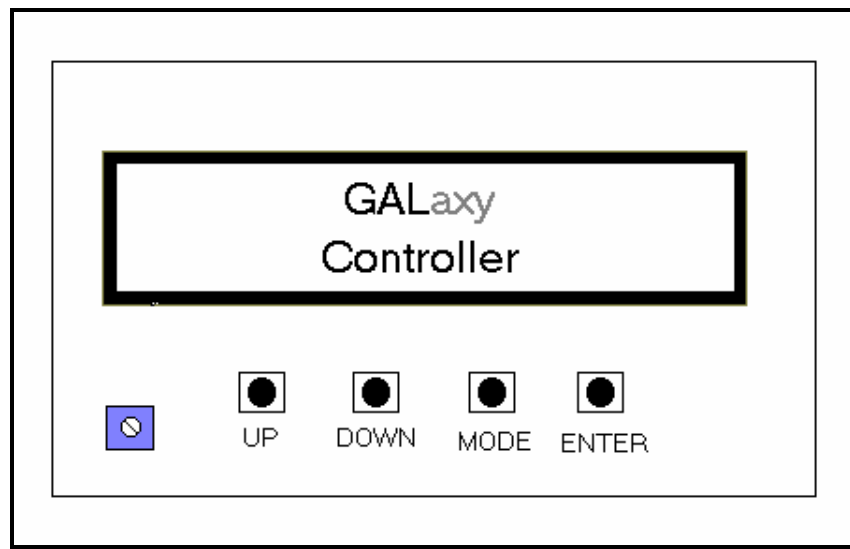

UP

UP button is used to scroll up to the next menu item or to increment a data value.



DOWN

DOWN button is used to scroll down to the next menu item or to decrement a data value.



MODE

MODE button is used to go back to the previous menu or to select a digit of a data value.



ENTER

ENTER button is used to select the menu item or to complete the operation of changing a data value.



Potentiometer is used to adjust the viewing angle. It will make the display lighter or darker.

The four inputs buttons used with the LCD display are, UP, DOWN, MODE and ENTER. The UP and DOWN buttons are used to scroll up and down to each menu item. When an appropriate menu item is reached, the ENTER button is used to select the item. Some menu items, once selected, show a second menu. Again, use the UP and DOWN buttons to scroll through the menu items and the ENTER button to select a particular

item. The MODE button is used to go back to the previous menu. When a menu item is an adjustable variable, select the item with the ENTER button and change the variable with the UP or DOWN button. The MODE button is used to move the cursor to the next digit. When the appropriate value is reached, use the ENTER button to complete the variable change operation and return to the current menu.

5.2 THE LCD MENU STRUCTURE

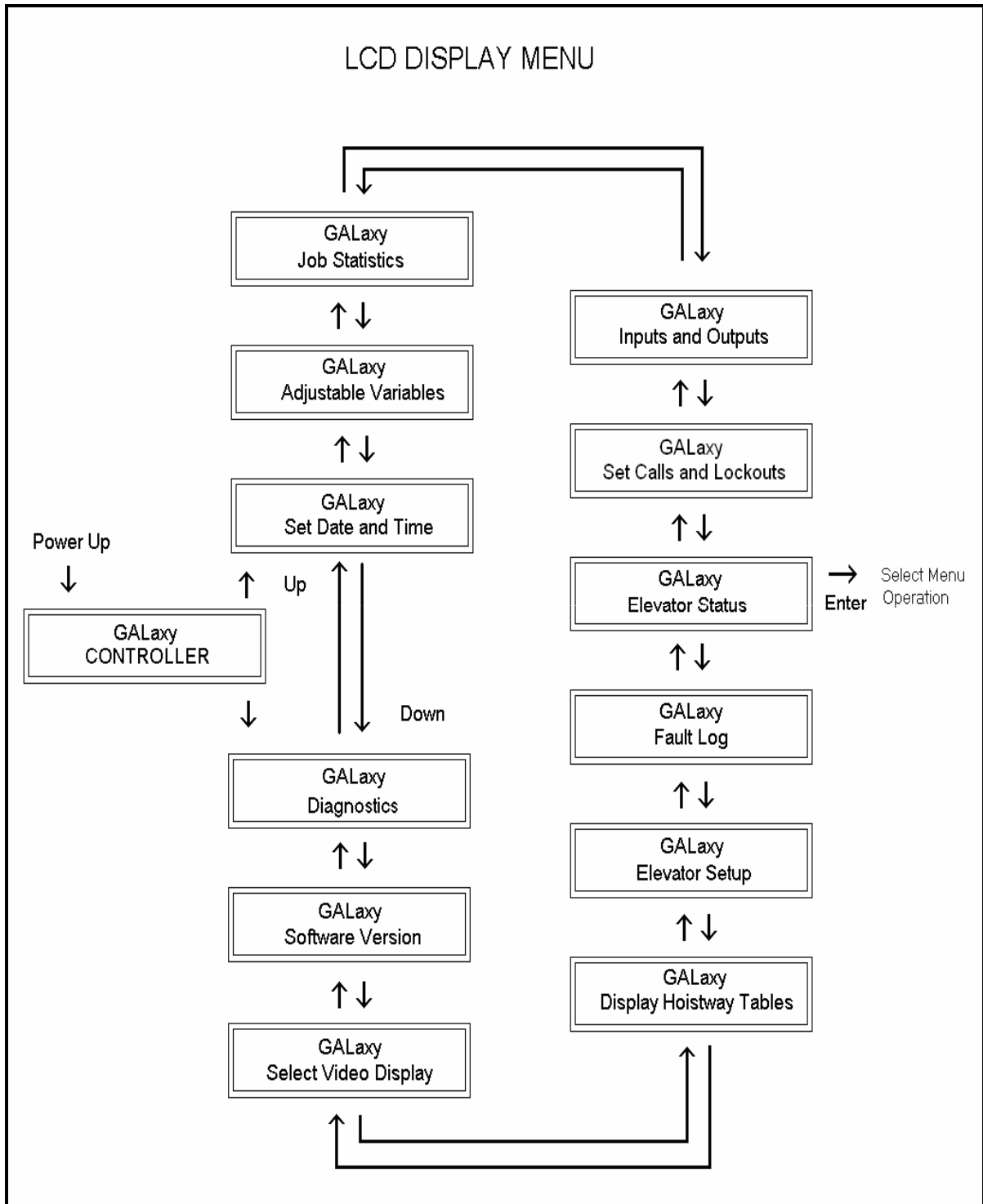

5.2.1 SET DATE AND TIME

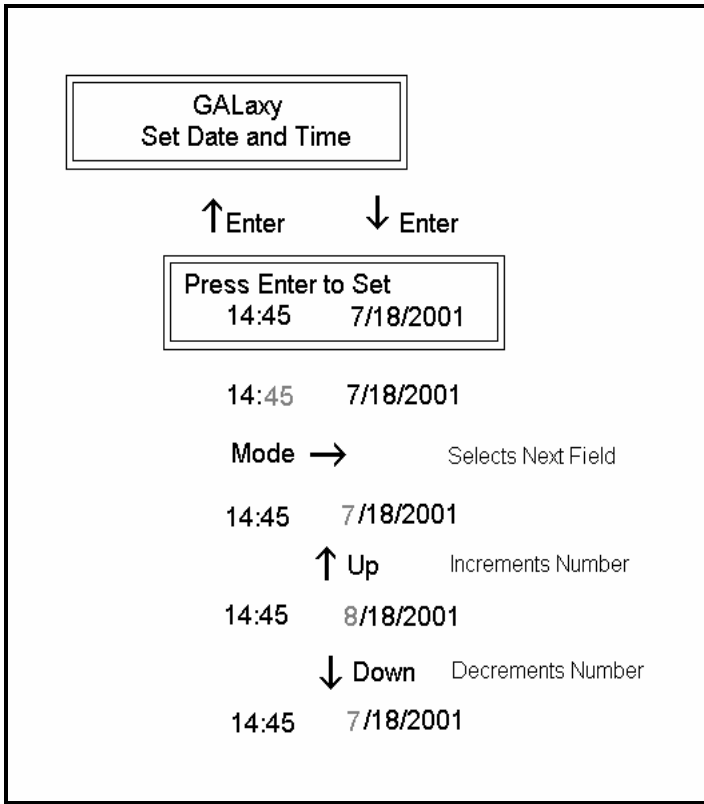

It is important to set the date and time on the controller clock so that the fault log shows the correct time sequence that faults occur

5.2.2 ADJUSTABLE VARIABLES

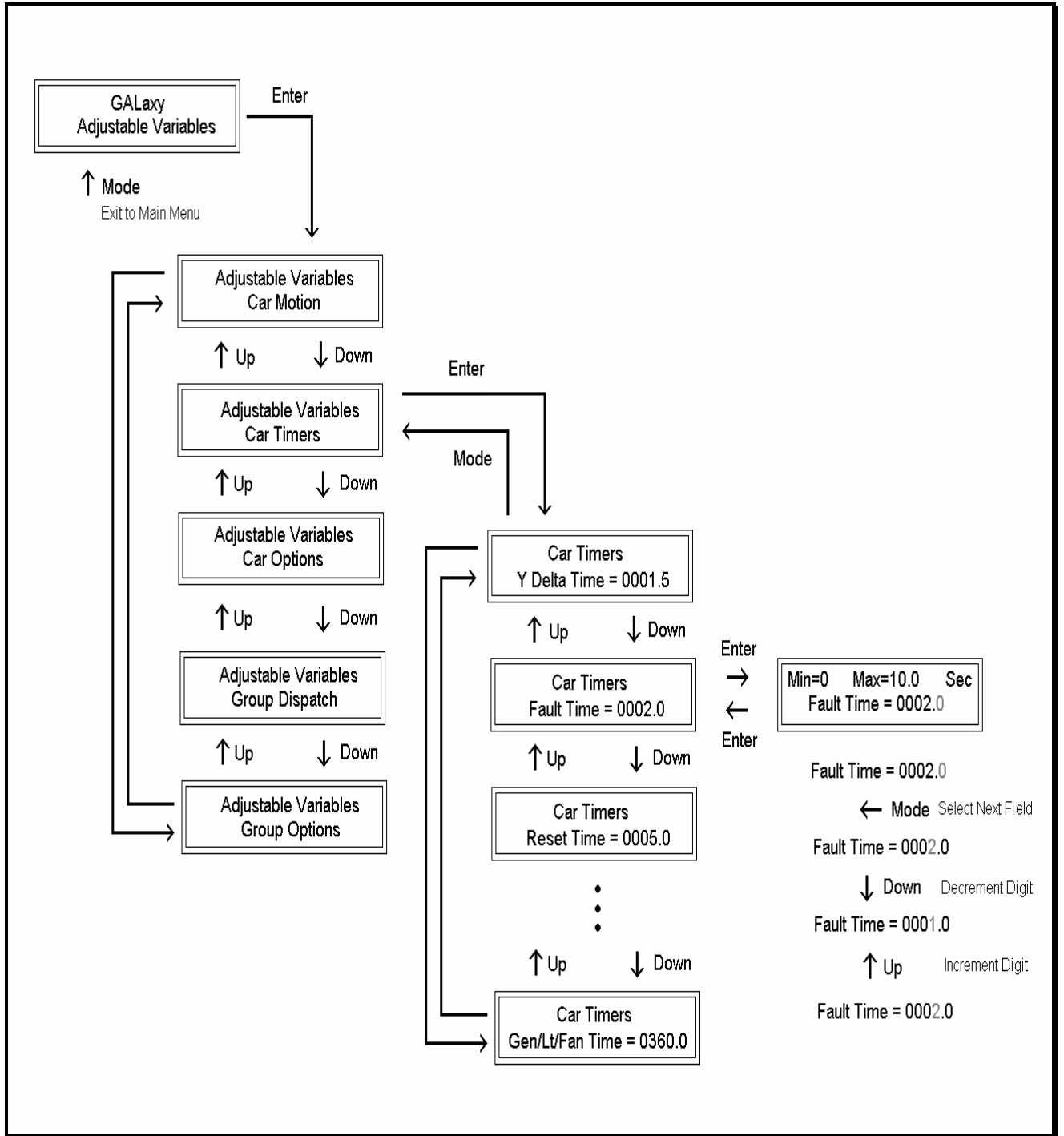

All field variables are adjustable from the LCD interface. Values can be changed within the valid minimum and maximum range. A complete list of

field adjustable variables and the minimum and maximum values for each is shown below:

Adjustable Variables

<u>Car Motion</u>	<u>Min</u>	<u>Max</u>	<u>Initial</u>	<u>Units</u>	<u>Description</u>
Inspect Speed	0	150	75	Fpm	Inspection Speed. Maximum car speed while running on inspection.
Soft Stop Time	0	3.0	1.0	Sec	Soft Stop Time. For Hydraulic Elevators – time the motor is kept running after the valve is turned off. For Traction Elevators – time that zero speed is held until the brake is set.
Preopen Delay	0	3200.0	0.5	Sec	Preopen Delay. Delay time to preopen the door starting from when the car reaches 3 inches from dead level and the door can safely be opened.

<u>Car Timers</u>	<u>Min</u>	<u>Max</u>	<u>Initial</u>	<u>Units</u>	<u>Description</u>
Y Delta Time	0	5.0	1.5	Sec	Transfer time to change motor from Y start to Delta run.
Fault Time	0	10.0	2.0	Sec	Fault Time. Delay time before allowing the car to run after a fault occurs.
Reset Time	0	10.0	5.0	Sec	Reset Time. Delay time in the reset mode before allowing the car to run.
Double Stroke	0	1	1	Gongs	Select 1 or 2 gongs for down hall calls. 0 = 1 gong and 1 = 2 gongs.
Lant On Time	0	2.0	0.7	Sec	Lantern On time. Used for double stroke gongs. The lantern will turn on, turn off and then turn on again. The Lantern on time is the delay time from when the lantern first turns on until it turns on the second time.
Lant Off Time	0	2.0	0.2	Sec	Lantern Off Time. Used for double stroke gongs. The lantern off time is the delay time after the lantern first turns on until it turns off.
Pas Chime Time	0.2	2.0	0.5	Sec	Floor Passing Chime Time. Length of time the floor passing chime will sound when a floor is passed.
Door Fail Time	10.0	3200.0	25.0	Sec	Door Fail Time. Time with power on the door without getting the door open limit.
Nudging Time	20.0	3200.0	60.0	Sec	Nudging Time. Delay time for a door to be held before going into nudging.
Car Call Dwell	1.0	60.0	2.0	Sec	Car Call Dwell. Door open dwell time when answering a car call only.
Hall Call Dwell	1.0	60.0	4.0	Sec	Hall Call Dwell. Door open dwell time when answering a hall call or both a hall and car call.
Lobby Dwell	1.0	60.0	5.0	Sec	Lobby Dwell. Door open dwell time for a car at the lobby.
Handicap Dwell	1.0	120.0	25.0	Sec	Handicap Dwell. Extended door time from pressing the ED button in the car.
Non Interfer T	1.0	60.0	2.0	Sec	Non-Interference Time. Time between when you stop from when you can run again.
Stall Time	30.0	3200.0	60.0	Sec	Stall Time. Maximum time a run is requested but

<u>Car Timers</u>	<u>Min</u>	<u>Max</u>	<u>Initial</u>	<u>Units</u>	<u>Description</u>
		0			the car is not moving.
Gen Run Time	30.0	3200.0	360.0	Sec	Generator Run Time. Length of time to leave the generator running after there is no longer a demand to run.
ATT Buz Delay	0.0	900.0	60.0	Sec	Attendant Buzzer Delay. Buzzer sounds if a hall call is entered and the car has not started moving within this delay time. This function is disabled when set to zero.
Door Delay Time	0.0	1.5	0	Sec	Door Delay Time. Delay time between DO and DC to switch when opening or closing the door.
Video Time-out	0.0	3200.0	0	Sec	Video Time-out. Turn off the machine room video after this timer times out. This function is disabled when set to zero.
ManDoor Buz Dly	0.0	900.0	0	Sec	Manual Door Buzzer Delay. On a car with manual doors, sound the buzzer if the door is left open and a call is entered after this time delay. This function is disabled when set to zero.

<u>Car Options</u>	<u>Min</u>	<u>Max</u>	<u>Initial</u>	<u>Units</u>	<u>Description</u>
Fire Main Floor	Bot	Top	1	Floor	Fire Main Floor.
Alt Fire Floor	Bot	Top	2	Floor	Alternate Fire Floor.
Fire Sw Loc	0	3	0	–	Fire Switch Location. Location of fire hall switch. 0 = Main/Alt Front, 1 = Main Rear/Alt Front, 2 = Main Front/Alt Rear, 3 = Main/Alt Rear.
Aux. Fire Sw.	0	1	0	–	Auxiliary Fire Switch. When set, the controller expects an auxiliary hall fire switch to be used.
Hall Fire Light	0	3	0	–	Hall Fire Light. The variable controls the FSO output on the controller so it can be used for a hall fire light or a fire security override. 0=PH1&2: FSO output on for both phase 1 and 2 fire service. 1=PH1: FSO output on while phase 1 fire is in effect. +2=flash: FSO is flashed at a 1 second interval while activated.
MachRm Fire Ret	0	1	0	–	Machine Room Fire Sensor Return Floor Selection. 0 = Return to the Main fire floor, 1 = Return to the Alternate fire floor.
Hoistw Fire Ret	0	1	0	–	Hoistway Fire Sensor Return Floor Selection. 0 = Return to the Main fire floor, 1 = Return to the Alternate fire floor.
Recall Reset	0	1	0	–	Recall Reset Selection. 0 = Reset fire service phase 1 after hall switch is turned off and car returns to fire floor. 1 = Reset phase 1 immediately after hall switch is turned off.
Lobby Floor	Bot	Top	1	Floor	Lobby Floor.
Med Em Floor	Bot	Top	1	Floor	Medical Emergency Return floor.
Med Em Sw Loc	0	1	0	–	Medical Emergency Switch Location. 0 = Medical Emergency is located at front door. 1 = Switch is located at rear door.
Brake Lift Switch	0	2	0	–	Brake Lift Switch. If set to 1 or 2 a brake lift switch fault is detected. The car is prevented from running if the brake does not drop or if the brake did not pick on the previous run. The car is allowed to run after the brake drops. If set to 2 the rope gripper will set if the brake does not drop and the can only be reset by placing the car on inspection and back to automatic.
Emerg Dispatch	0	1	0	–	Emergency Dispatch. If set and hall call power lost, the group will set down hall calls above the lobby and up hall call at and below the lobby. Also if comm. is lost to a particular hall call board, hall calls are set for the affected floors.
DOB Over Nudg	0	1	0	–	DOB Over Nudging. If set the door open button will open the door when the door is nudging closed.

<u>Car Options</u>	<u>Min</u>	<u>Max</u>	<u>Initial</u>	<u>Units</u>	<u>Description</u>
LW-Antinus	0	29	0	Floors	Load Weighing Anti-nuisance. Set to the maximum number of car calls that can be entered before all car calls are cancelled without the load switch LWA input on. Once the load switch is on, all car calls will stay latched. If set to 0, this function is disabled.
No Psg Run Cnt	0	10	0	# of Runs	No Passenger Run Count. When set to a number other than zero, the car call anti-nuisance feature is activated. This count is the number of times to the car will run from a car call without detecting that a passenger has broken the detector edge. Once the count is reached, all remaining car calls will be cancelled.
Ind Over Sec	0	1	0	–	Independent Overrides Security. Set to 1 to allow independent service to override security car call lockouts.
User Baud Rate	0	3	0	Bits/sec	User Interface Baud Rate. 0=2400, 1=4800, 2=9600 and 3=19200 bits per second.
Diagnostic LED	0	1	0	Off/on	Diagnostic LED. Enable diagnostic LEDs on A1010 board.
Safe Test Year	2000	2999	0	Years	Safety Test Year.
Safe Test Month	1	12	0	Months	Safety Test Month.
Safe Test Day	1	31	0	Days	Safety Test Day.
Invert ISER	0	1	0	–	Invert In Service Output. When set to 1, the in service light output is turned off when the car is in service instead of turned on.
Ins Door Close	0	1	0	–	Inspection Door Close. When set to 1, the door close output will turn on when the up or down inspection run button is pressed.
COP/Remote CC	0	7	0	–	COP/Remote Car Call Select. 0=Bo: Both COP and Remote Car Call Station used to enter calls. 1=Separate: COP only or Remote CC only used to enter car calls. +2=C-R: Car calls entered on the COP sets the acknowledgement light on the Remote station. +4=R-C: Car calls entered on the Remote station sets the acknowledgement light on the COP.
Security Recall	0	7	0	–	Security Recall Selection. 0=No: No Recall, +1=Recl: Recall to Security Floor on activation of security. +2=fD: Cycle front door once recalled to the Security Floor. +4=rD: Cycle rear door once recalled to the Security Floor.
Security Floor	Bot	Top	1	Floor	Security Floor. The security recall floor. This is the floor where the security guard would be stationed. This floor would not be locked out when on security.
DOB Over Sec	0	1	0	–	DOB Override Security. When set to 1, the DOB will be allowed to open the door at a secured floor.

Group Dispatch	Min	Max	Initial	Units	Description
Parking	0	4	1	Car	Number of Cars to Park. One car is parked at the lobby. The remaining cars are parked at the most used floors of the building. If set to zero, no cars are parked.
Park Delay Time	0	120.0	8.0	Sec	Parking Delay Time. Time delay an idle car waits before being parked.
Lobby Request	0	4	0	Car	Lobby Request. Number of Cars Requested to the Lobby floor. Used with Next Car Up operation.
Next Car Up	0	2	0	-	Next Car Up. Set to 1 or 2 will activate the Next Car Up operation. If set to 1 the next up car will open its door at the lobby and keep it open. The car is allowed to leave the floor after the Lobby Dwell time expires but will remain at the floor with the door open until an onward call is assigned to it. If set to 2 the next up car will close the its door after the Lobby Dwell time expires and go off of next up but will remain at the lobby. An up hall call at the lobby will cause the car to open its door and go on next up.
Up Pk Trig Time	0	3200.0	60.0	Sec	Up Peak Trigger Time. The time interval to count the number of up peak triggers.
Up Pk Trig Cnt	1	100	3	Count	Up Peak Trigger Count. The number of up peak triggers that are set within the up peak trigger time to activate up peak operation. Up peak triggers are counted when the car leaves the lobby with the load dispatch input set or with the more car calls than the up peak car call count.
Up Pk CC Count	1	40	3	Car Call Count	Up Peak Car Call Count. Number of car calls the car must have when leaving the lobby to count as an up peak trigger.
Up Peak Time	0	3200.0	180.0	Sec	Up Peak Duration Time. The duration time for up peak operation once up peak is activated.
Dn Pk Trig Time	0	3200.0	60.0	Sec	Down Peak Trigger Time. The time interval to count the number of down hall calls above the lobby to activate down peak operation.
Dn Pk Trig Cnt	1	100	12	Down Hall Call Count	Down Peak Trigger Count. Number of down hall calls above the lobby that are set within the down peak trigger time to place the system on down peak operation.
Down Peak Time	0	3200.0	180.0	Sec	Down Peak Duration Time. The duration time for down peak operation once down peak is activated.
ETA Min Time	0	60	6	Sec	ETA Minimum Time. For a hall call to be assigned to a new car, the difference in ETA must be greater than the ETA Minimum Time.
ETA Co CC Time	0	60	15	Sec	ETA Coincident Car Call Time. Hall calls will be assigned to the car with the coincident car call unless

<u>Group Dispatch</u>	<u>Min</u>	<u>Max</u>	<u>Initial</u>	<u>Units</u>	<u>Description</u>
					the car without the coincident car call can reach the call faster then ETA Coincident Car Call Time.

<u>Group Options</u>	<u>Min</u>	<u>Max</u>	<u>Initial</u>	<u>Units</u>	<u>Description</u>
Em Power Floor	1	29	1	Floor	Emergency Power Recall Floor.
Em Power Cars	1	4	1	Car	Number of Emergency Power Cars that can run at the same time on the emergency power source.
1 st Recall Car	0	4	1	Car	First Recall Car. This is the first car allowed to recall during the recall sequence. The recall sequence continues in consecutive order and then loops around until all cars are recalled.
1 st EP Run Car	0	4	1	Car	First Emergency Power Run Car. This is the first car selected to run. If this car cannot run, the next consecutive car is selected.
Recall Timeout	1.0	600.0	60.0	Sec	Recall Time-out. The time allowed for the car to reach the recall floor. If this timer expires, the next car is selected to recall.
Code Blue Car	0	4	0	Car	Code Blue Car. If set to zero, the best ETA car will be assigned the code blue call. If set to a car number, the selected car will always be assigned the code blue call.
IR Car	0	4	0	Car	Inconspicuous Riser Car. This car is assigned all the IR hall calls.
IR Control	0	7	0	1=IREn 2=AnCB4S 4=AnCB4F	Inconspicuous Riser Control. This variable is used to set the automatic activation of IR service. Add each number to activate the option. 1 = IREn: Enable IR automatic activation. +2=AnCB4S: Answer all Car calls Before Starting IR service. +4=AnCB4F: Answer all Car calls Before Finishing IR service.
Vid Pos Car 1	1	6	1	Column Position	Video Position Car 1. The column where the car is displayed on the dispatch screen starts from left to right for positions 1 through 6. Car 1 through 6 positions are defaulted to display positions 1 through 6 respectively. Changing the car's video position changes the column where the car is displayed.
Vid Pos Car 2	1	6	2	Column Position	Video Position Car 2. See Video Position Car 1 for an explanation.
Vid Pos Car 3	1	6	3	Column Position	Video Position Car 3. See Video Position Car 1 for an explanation.
Vid Pos Car 4	1	6	4	Column Position	Video Position Car 4. See Video Position Car 1 for an explanation.

<u>Group Options</u>	<u>Min</u>	<u>Max</u>	<u>Initial</u>	<u>Units</u>	<u>Description</u>
Vid Pos Car 5	1	6	5	Column Position	Video Position Car 5. See Video Position Car 1 for an explanation.
Vid Pos Car 6	1	6	6	Column Position	Video Position Car 6. See Video Position Car 1 for an explanation.
HC X-Assign En	0	1	0	–	Hall Call Cross Assignment Enabled. Set to enable cross assign with old elevator system.
HC X-Assign ETA	0	500	60	Sec	Hall Call Cross Assignment ETA limit. If ETA for hall call assignment is greater than this ETA limit, the hall call will be cross-assigned to the old group controller.

5.2.3 JOB STATISTICS

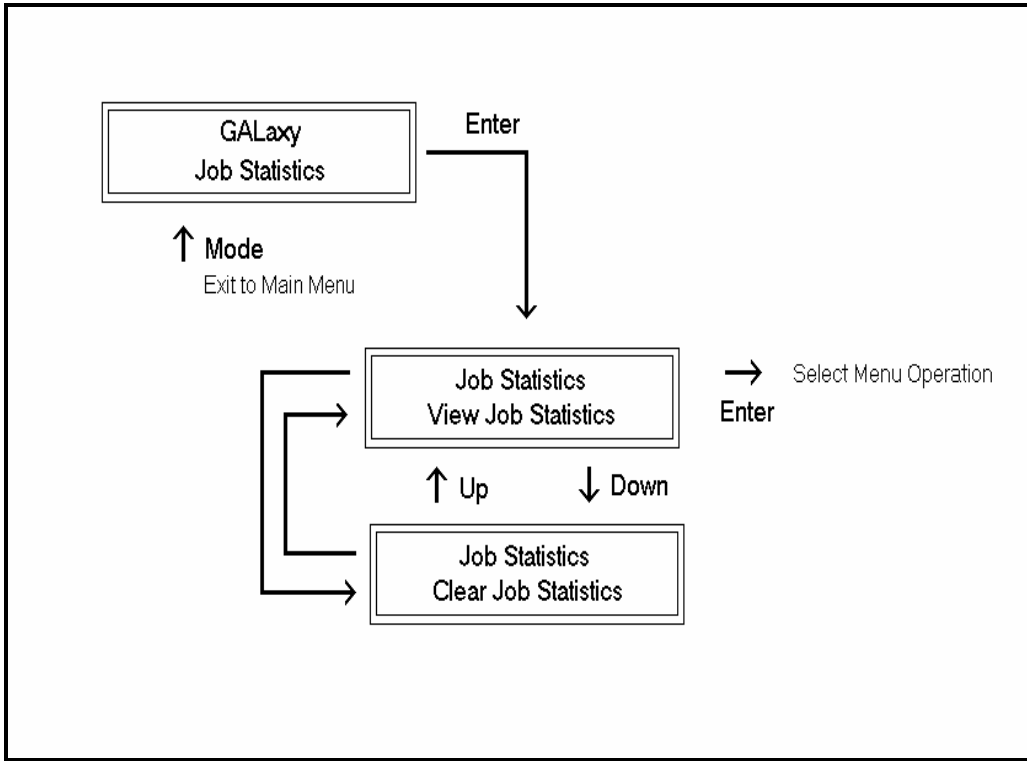

Select to view or clear job statistics from this menu.

5.2.3.1 VIEW JOB STATISTICS

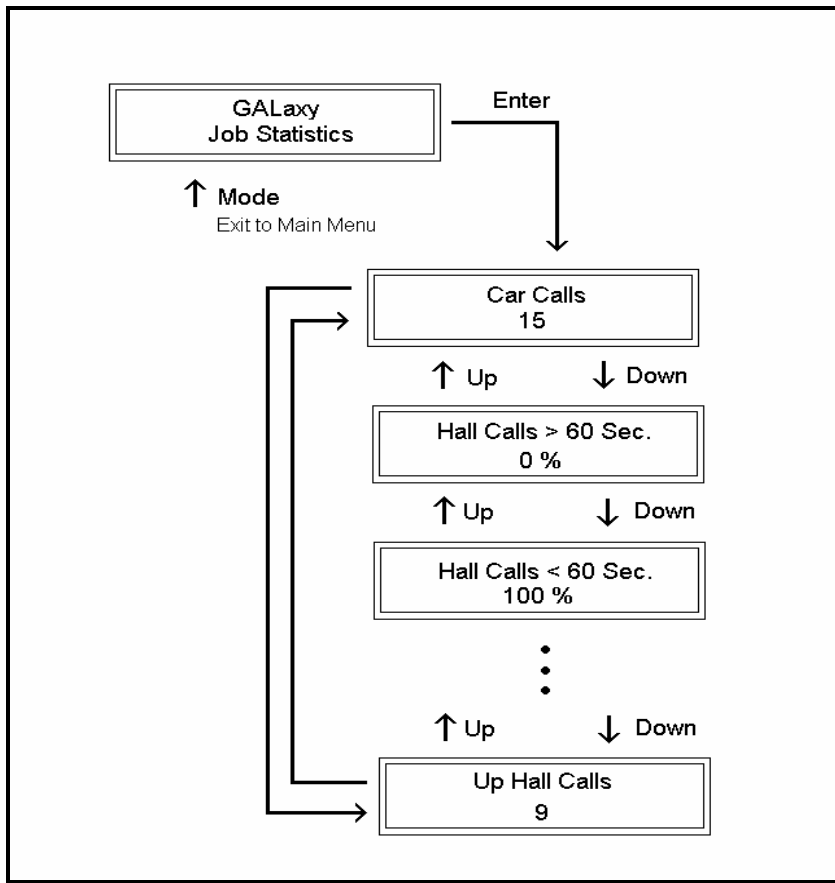

The Job Statistics shows the number car calls and the number and percent of hall calls serviced since the job was started or since the job statistics were cleared. Below is a list of all the categories maintained:

- Number of Car Calls
- Number of Up Hall Calls
- Number of Down Hall Calls
- Number of Up Hall Calls with < 15 second wait time
- Number of Up Hall Calls with < 30 second wait time
- Number of Up Hall Calls with < 45 second wait time
- Number of Up Hall Calls with < 60 second wait time
- Number of Up Hall Calls with > 60 second wait time
- Number of Down Hall Calls with < 15 second wait time
- Number of Down Hall Calls with < 30 second wait time
- Number of Down Hall Calls with < 45 second wait time
- Number of Down Hall Calls with < 60 second wait time
- Number of Down Hall Calls with > 60 second wait time
- Percent of Hall Calls with < 15 second wait time
- Percent of Hall Calls with < 30 second wait time
- Percent of Hall Calls with < 45 second wait time
- Percent of Hall Calls with < 60 second wait time
- Percent of Hall Calls with > 60 second wait time

5.2.3.2 CLEAR JOB STATISTICS

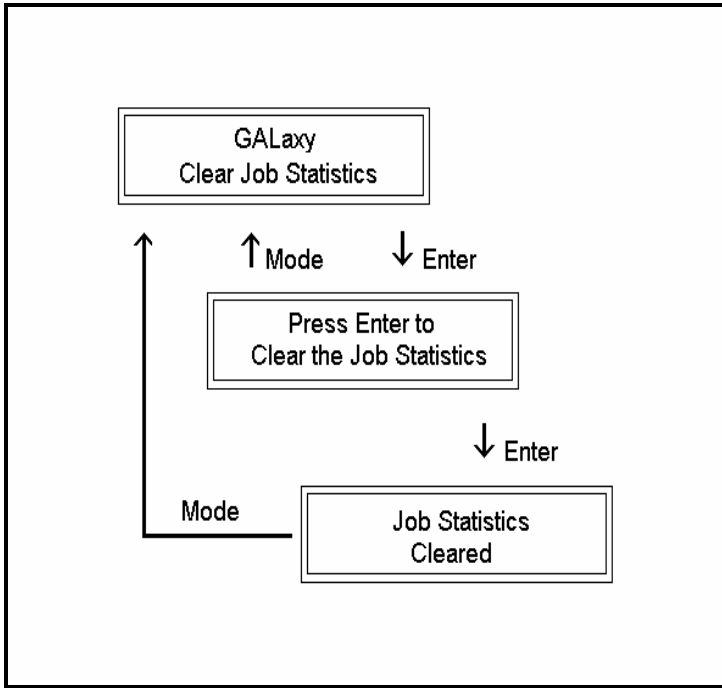

This operation will set all the job statistics data to zero.

5.2.4 INPUTS AND OUTPUTS

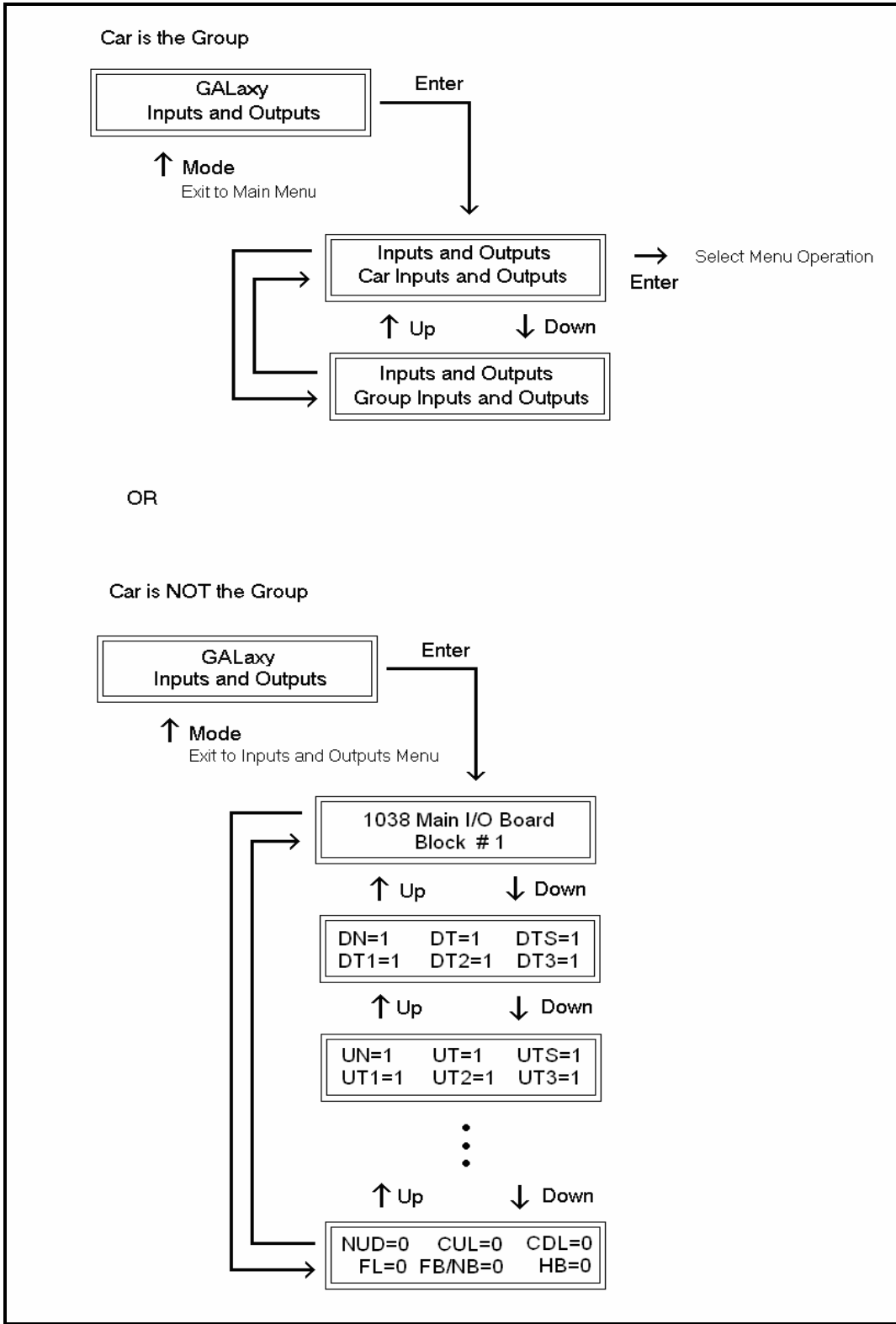

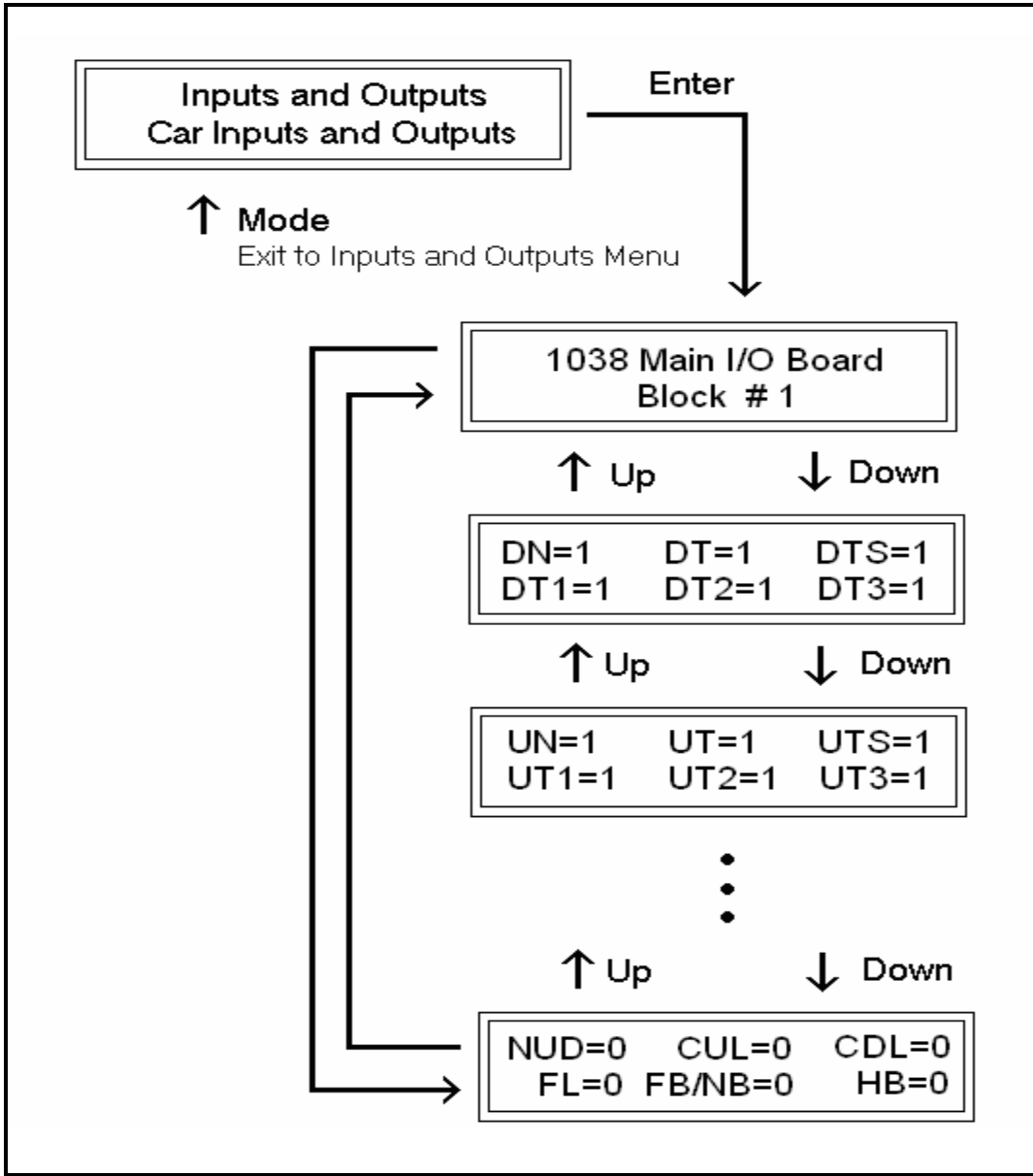

Inputs and outputs show a “1” for ON and a “0” for OFF. A list every input and output used on the controller and the board it is located on is shown in Appendix A. The controller determines which

boards are used depending on the options selected and the number of front and rear floors. All the I/Os for a given board are displayed even if a particular I/O is not used.

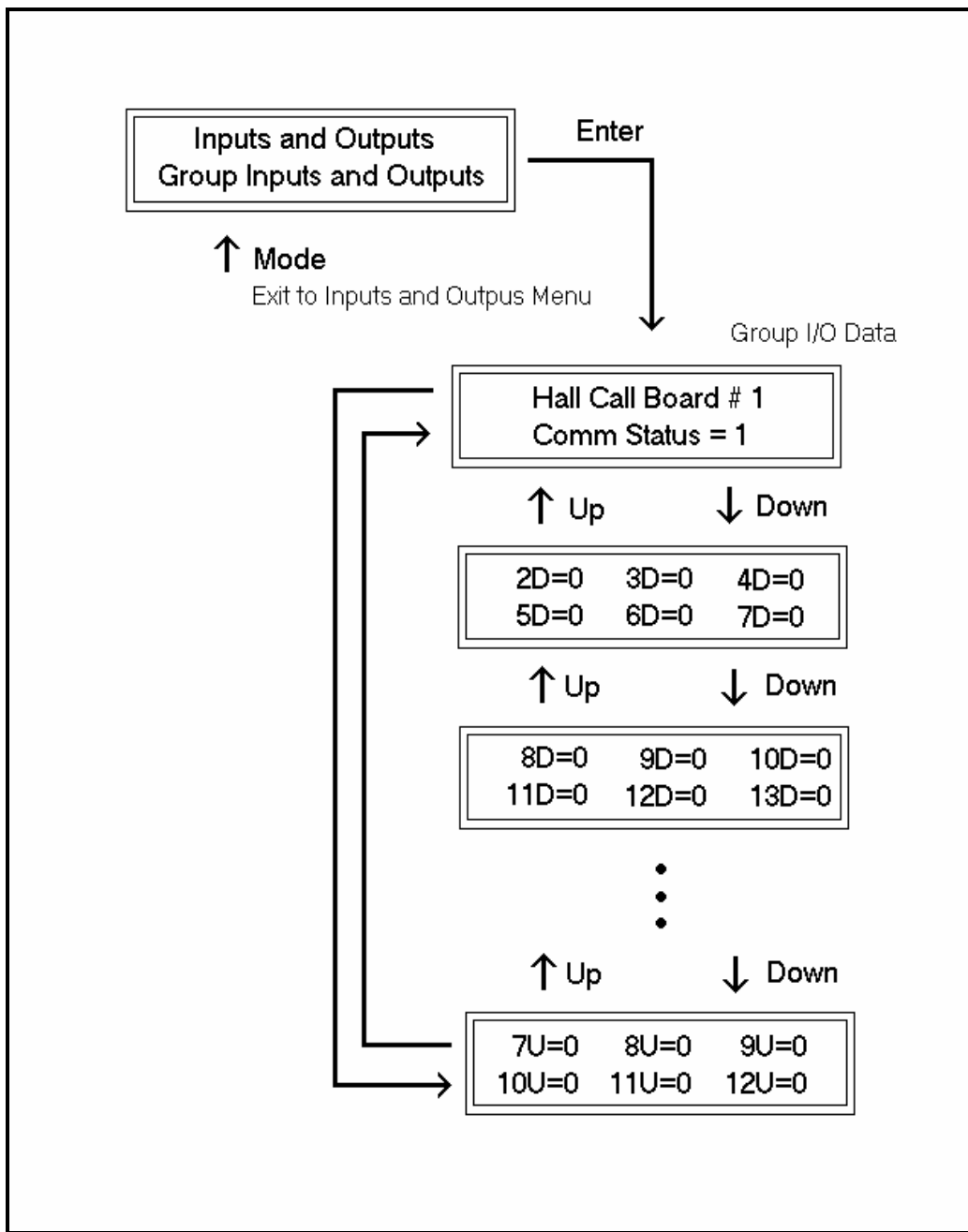

Inputs and outputs show a “1” for ON and a “0” for OFF. This I/O display is show only in the group car and only when serial hall call board are used. It the hall calls are place on the standard car I/O they will be shown with the car I/O screen. A list every input

and output used on the controller and the board it is located on is shown in Appendix A. All the I/Os for a given board are displayed even if a particular I/O is not used.

5.2.5 SET CALLS AND LOCKOUTS

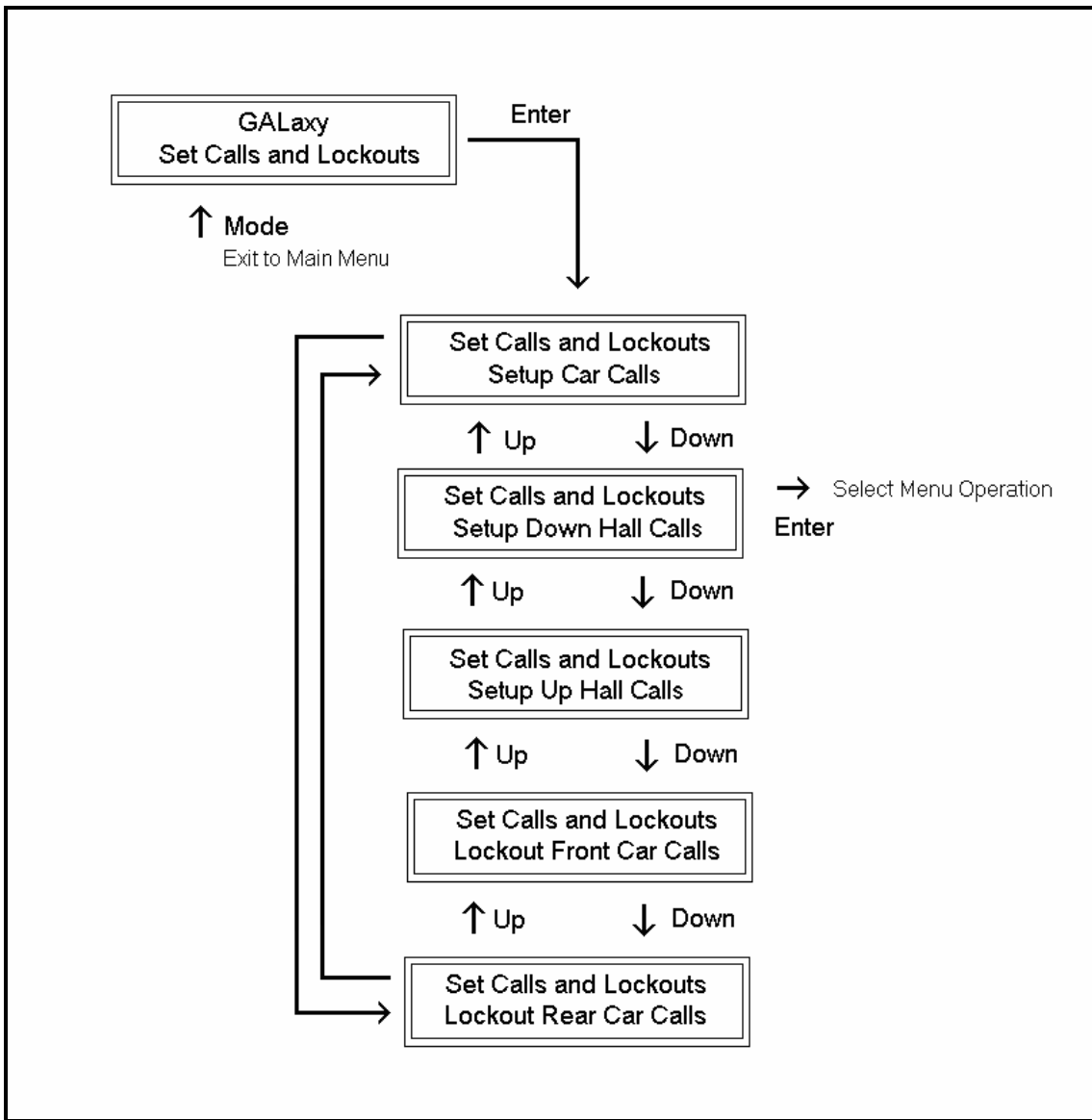

When a car is the group the menu system allows access to setting both hall calls and car calls. When not the group, only car calls can be set.

Rear lockouts are only displayed only when the car has a rear door.

5.2.5.1 SETUP CAR CALLS

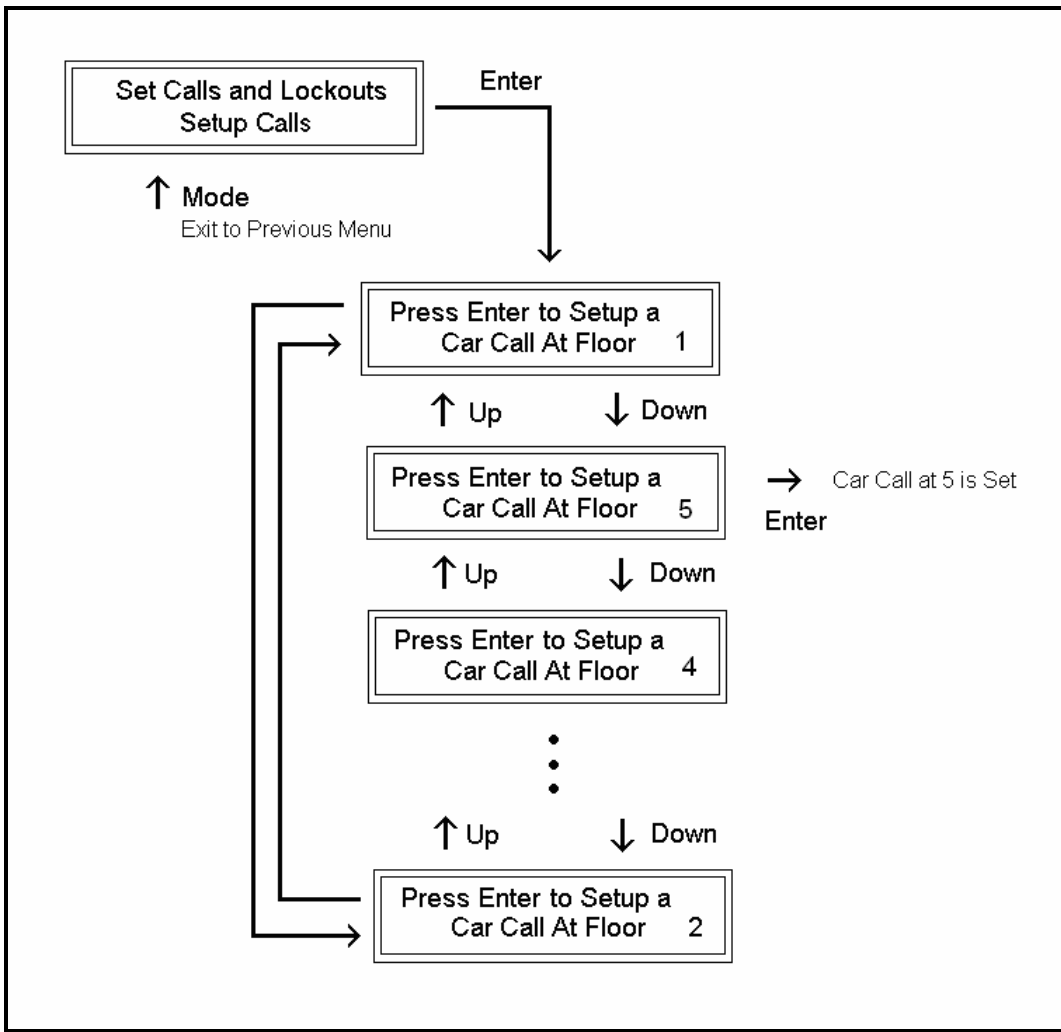

5.2.5.2 SETUP DOWN HALL CALLS

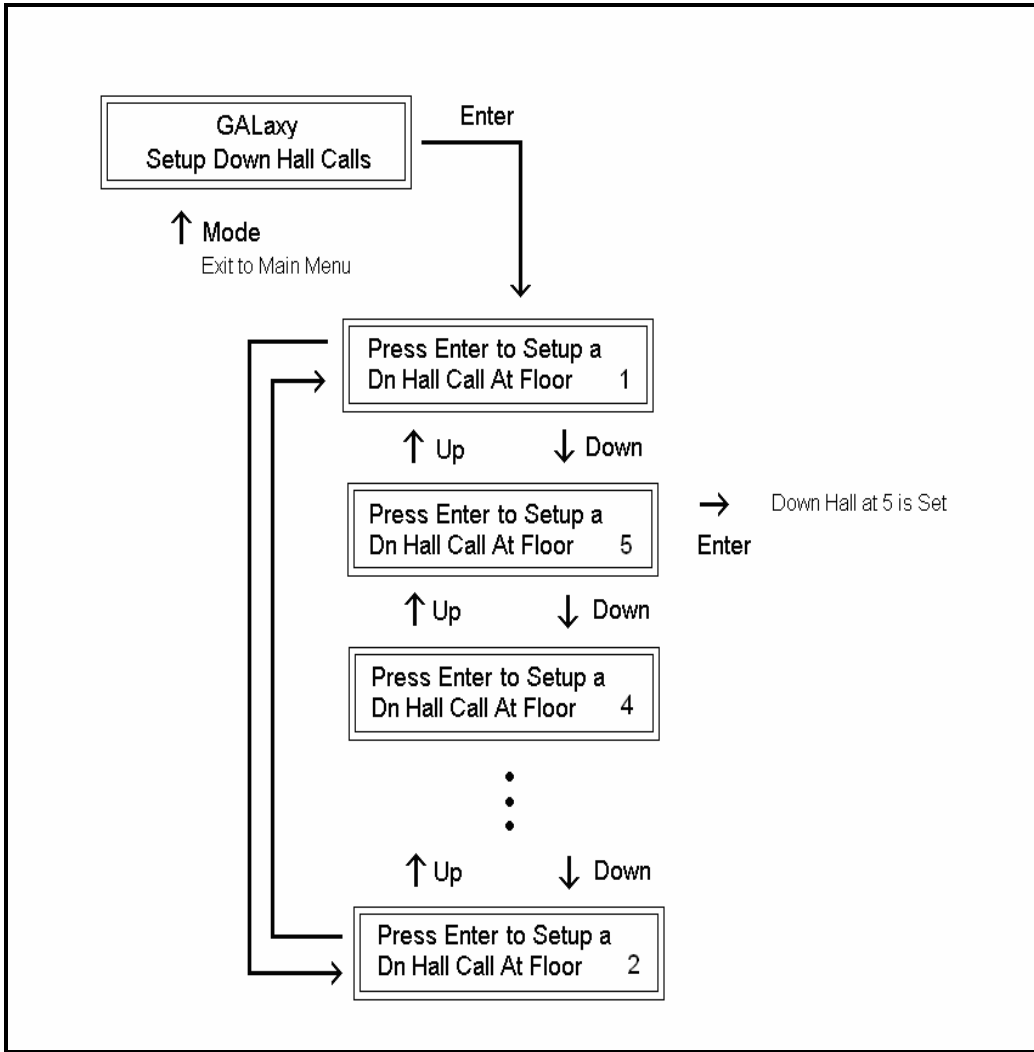

5.2.5.3 SETUP UP HALL CALLS

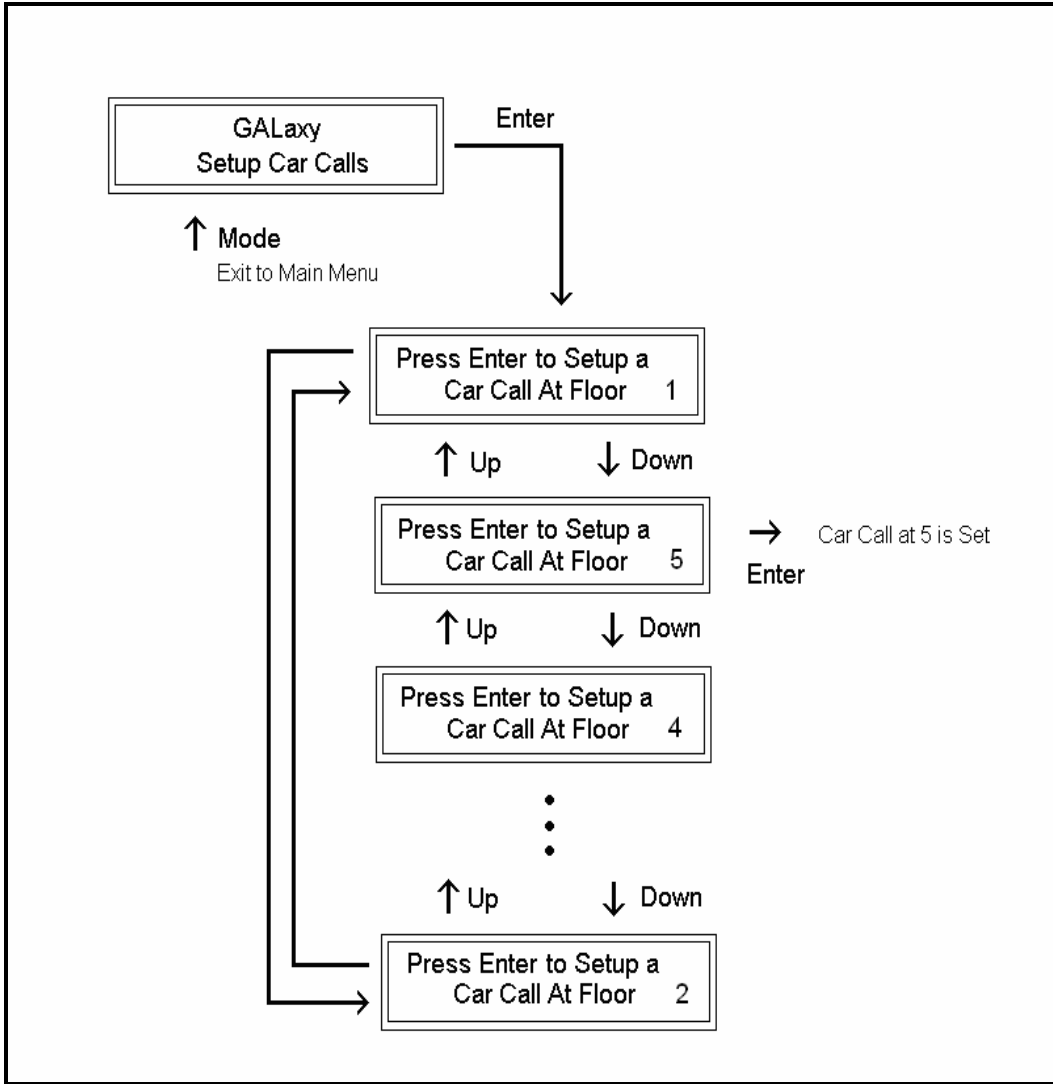

5.2.5.4 LOCKOUT FRONT CAR CALL

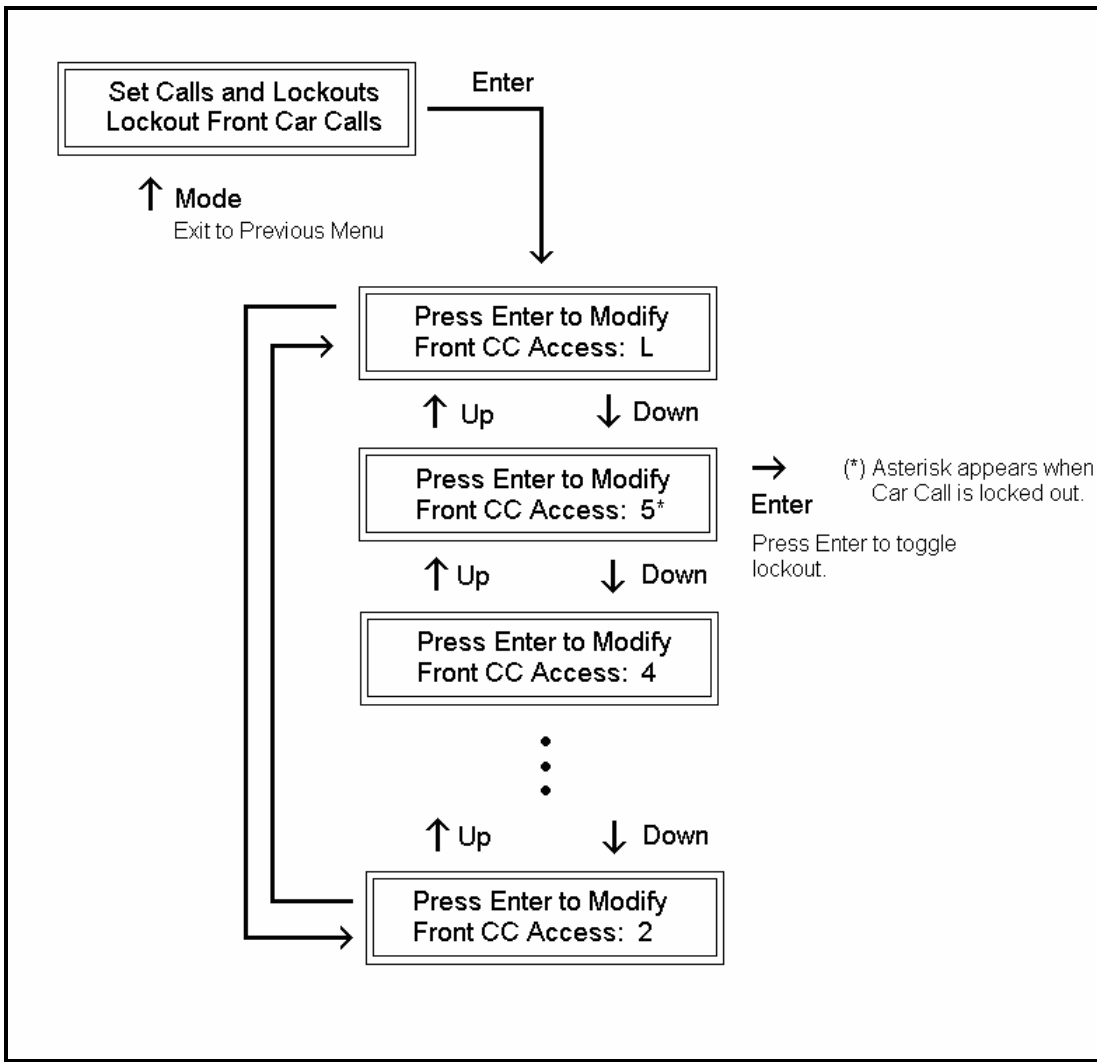

5.2.5.5 LOCKOUT REAR CAR CALL

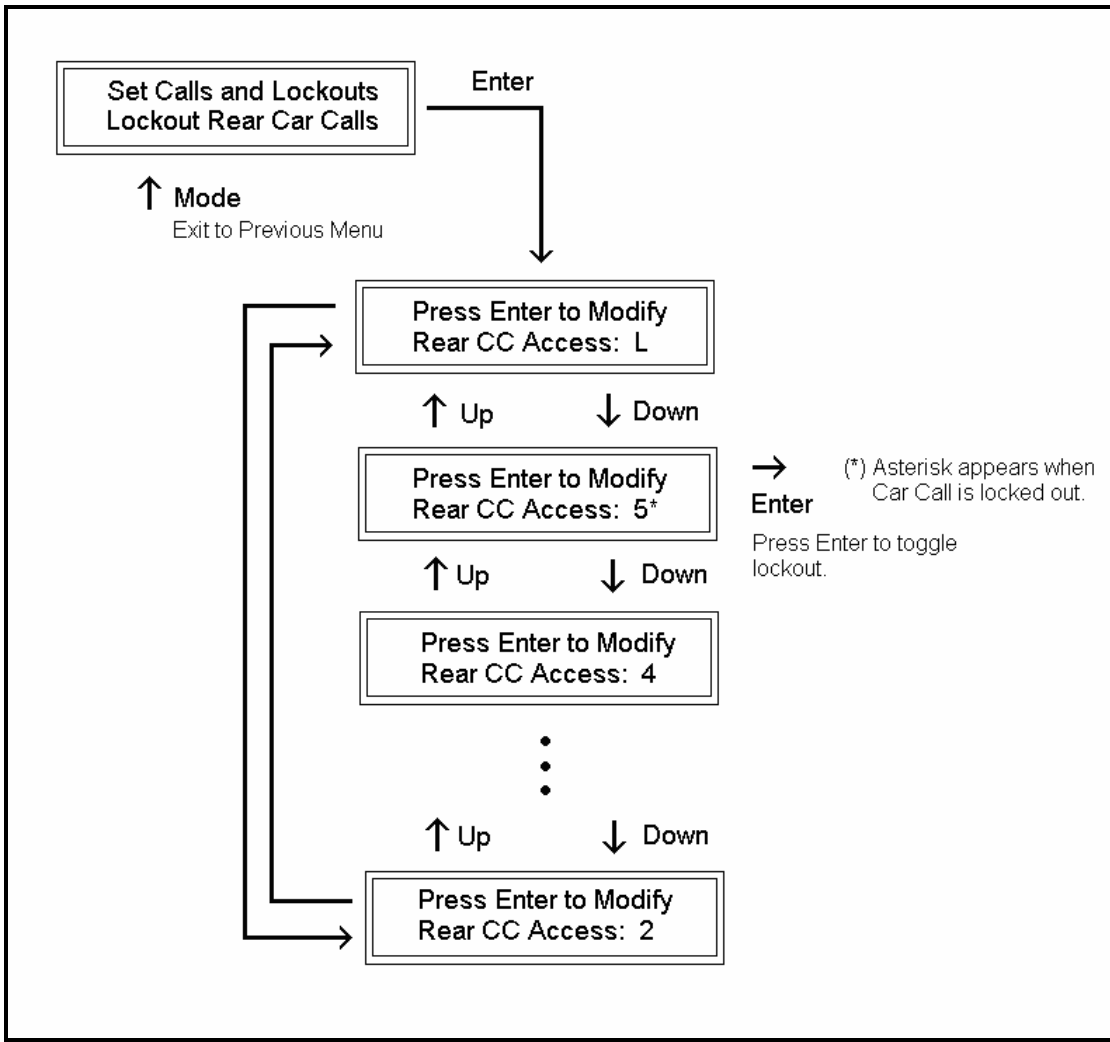

5.2.6 ELEVATOR STATUS

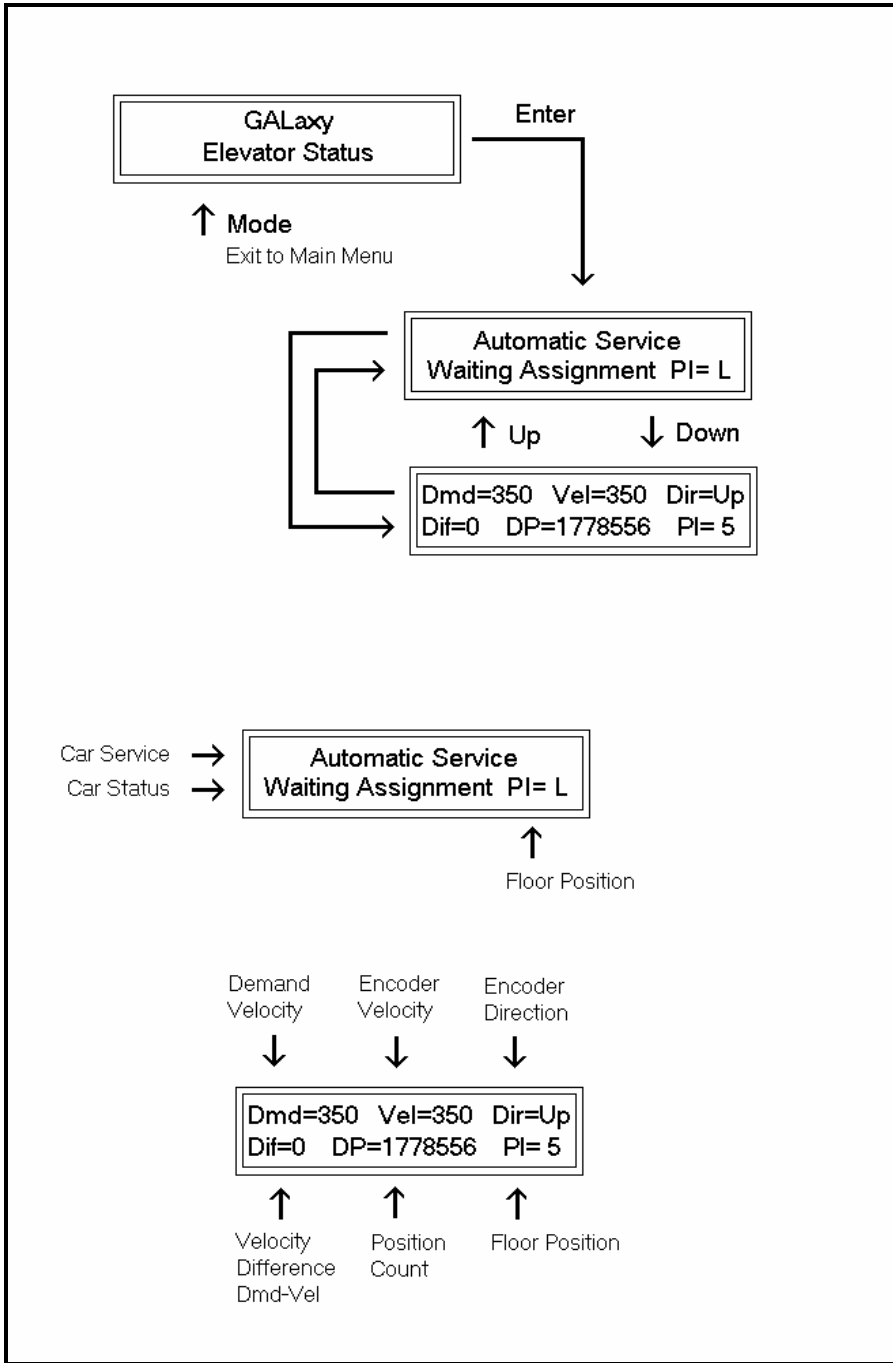

The elevator status display continuously updates to show the current status and fault information. The Up and Down keys allows access to both status display and the velocity display. When a system fault occurs, it will be displayed on the top line of the status display while the fault exist and will remain for

60 seconds after the fault is cleared. The following status information can be displayed:

Elevator Service:

Out of Service
Automatic Service
Independent Service
Load Weighing By Pass
Attendant Service
Code Blue Service
Fire Service Phase 2
Emergency Power Service
Earth Quake Service
Fire Phase 1 Main Return
Fire Phase 1 Alt Return
Homing
Reset Going Up
Reset Going Down
Stalled Out of Service

Fault Status:

Reset Fault
Out Of Step Fault
Binary Input Fault
Safety String Fault
Door Zone Fault
Stalled Fault
Door Open Fault
Door Close Fault
Up Directional Fault
Dn Directional Fault
No Potential Fault
Stop Switch Fault
Gate or Interlock
LC Fuse Blown Fault
HC Fuse Blown Fault
Drive Ready Fault
'P' Input Off Fault
Car Safe Fault
UL or DL off Fault
Delta off Fault
UT count Fault
UT1 count Fault
UT2 count Fault
UT3 count Fault
DT count Fault
DT1 count Fault
DT2 count Fault
DT3 count Fault
Rear Door Open Flt
Rear Door Close Flt
Group Comm Loss
Car 1 Comm Loss
Car 2 Comm Loss

Car 3 Comm Loss
Car 4 Comm Loss
Car 5 Comm Loss
Car 6 Comm Loss
RUN I/O Failed ON
Fault #39
RUN I/O Failed OFF
RUNA I/O Failed ON
RUNA I/O Failed OFF
UP I/O Failed ON
UP I/O Failed OFF
DNR I/O Failed ON
DNR I/O Failed OFF
UPF I/O Failed ON
UPF I/O Failed OFF
DF I/O Failed ON
DF I/O Failed OFF
MCC I/O Failed ON
MCC I/O Failed OFF
MCA I/O Failed ON
MCA I/O Failed OFF
BRK I/O Failed ON
BRK I/O Failed OFF
DON I/O Failed ON
DON I/O Failed OFF
RUN I/O or UP Fail
RUN I/O or DNR Fail
Top Door Lock Fault
Mid Door Lock Fault
Bot Door Lock Fault
Gate Switch Fault
Rear Top Lock Fault
Rear Mid Lock Fault
Rear Bot Lock Fault
Rear Gate Sw Fault
'P' Input On Fault
Estop Fault
Inspection Input Flt
Gate/Lock Byp Sw Flt
GRT1 input ON Fault
GRT1 input OFF Fault
GRT2 input ON Fault
GRT2 input OFF Fault
Gripper did not Pick
Gripper Trip Fault

Elevator Status:

Reset Mode PI= 1
Inspection Mode PI= 1
Up Fast PI= 1

Up Transition	PI= 1
Leveling Up	PI= 1
Down Fast	PI= 1
Down Transition	PI= 1
Leveling Down	PI= 1
Soft Start Mode	PI= 1
Constant Accel	PI= 1
Roll Over Max Vel	PI= 1
Constant Velocity	PI= 1
Roll Over Deccel	PI= 1
Constant Deccel	PI= 1
Targeting Floor	PI= 1
Emergency Slowdown	PI= 1
Safety String Open	PI= 1
Elevator Off Line	PI= 1
Elevator Parked	PI= 1
Waiting Assignment	PI= 1
Door Procedure	PI= 1
Elevator Stalled	PI= 1

Door Status:

Elev Door Closed	PI= 1
Elev Door Opening	PI= 1
Elev Door Dwelling	PI= 1
Elev Door Open	PI= 1
Elev Door Closing	PI= 1
Elev Door Nudging	PI= 1
F1RET Door Open	PI= 1
F2CPO Door Open	PI= 1
F2CPO Door Opening	PI= 1
F2CPO Door Closed	PI= 1
F2CPO Door Closing	PI= 1
F2CPC Door Open	PI= 1
F2CPC Door Opening	PI= 1
F2CPC Door Closed	PI= 1
F2CPC Door Closing	PI= 1

F2HLD Door Open	PI= 1
F2HLD Door Opening	PI= 1
F2HLD Door Closed	PI= 1
F2HLD Door Closing	PI= 1
F2MBC Door Open	PI= 1
F2MBC Door Opening	PI= 1
F2MBC Door Closed	PI= 1
F2MBC Door Closing	PI= 1

Rear Door Status:

Rear Door Closed	PI= 1
Rear Door Opening	PI= 1
Rear Door Dwelling	PI= 1
Rear Door Open	PI= 1
Rear Door Closing	PI= 1
Rear Door Nudging	PI= 1
F1RET RDor Open	PI= 1
F2CPO RDor Open	PI= 1
F2CPO RDor Opening	PI= 1
F2CPO RDor Closed	PI= 1
F2CPO RDor Closing	PI= 1
F2CPC RDor Open	PI= 1
F2CPC RDor Opening	PI= 1
F2CPC RDor Closed	PI= 1
F2CPC RDor Closing	PI= 1
F2HLD RDor Open	PI= 1
F2HLD RDor Opening	PI= 1
F2HLD RDor Closed	PI= 1
F2HLD RDor Closing	PI= 1
F2MBC RDor Open	PI= 1
F2MBC RDor Opening	PI= 1
F2MBC RDor Closed	PI= 1
F2MBC RDor Closing	PI= 1

5.2.7 FAULT LOG

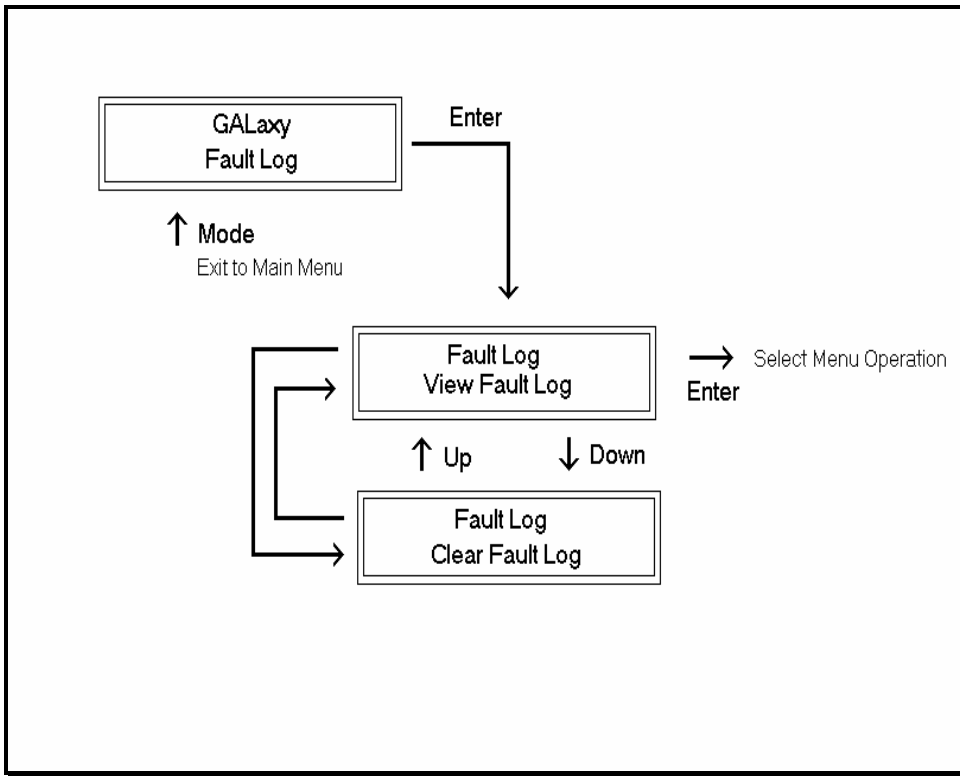

This menu allows the user to view or clear the fault log.

5.2.7.1 VIEW FAULT LOG

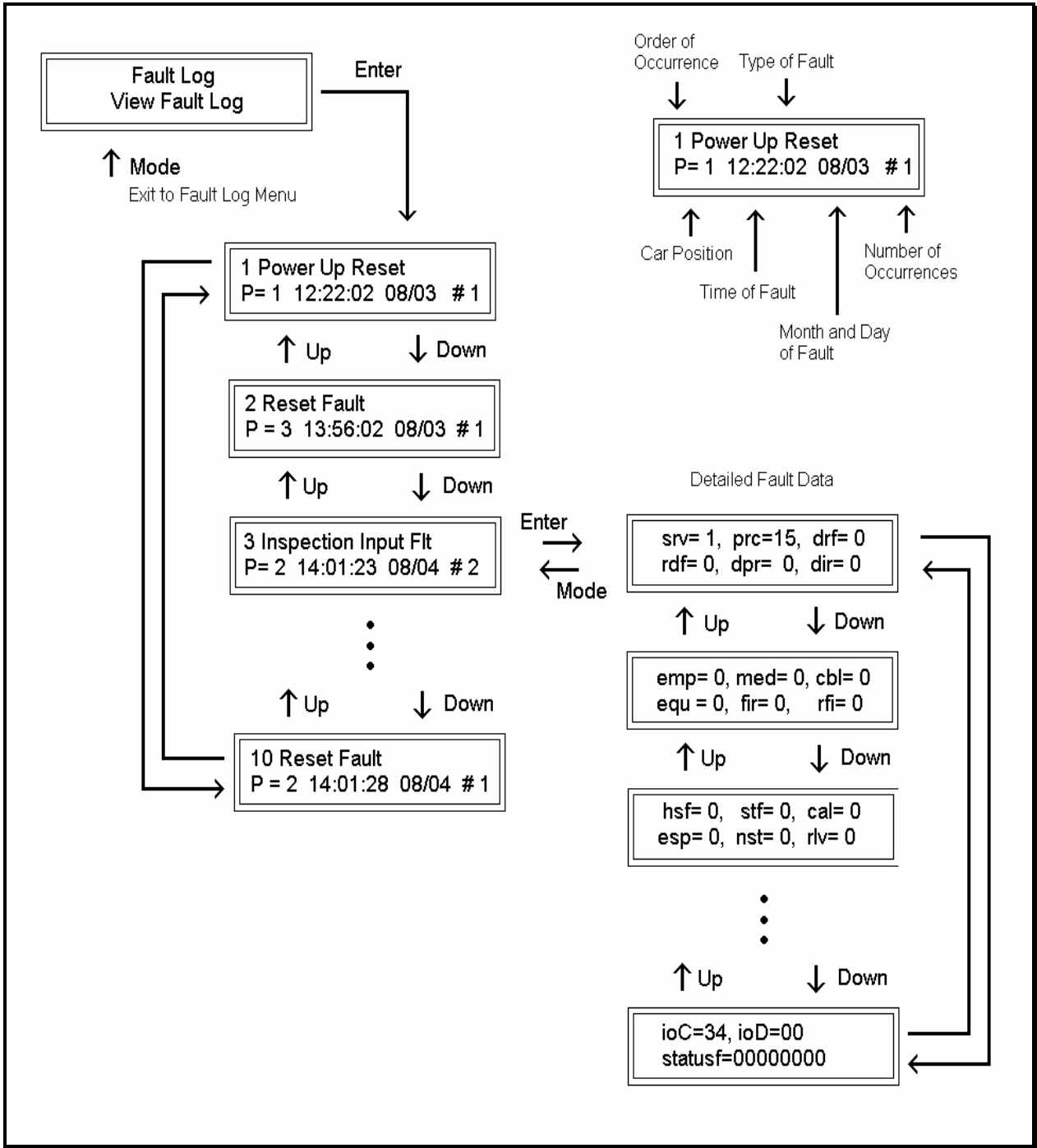

The fault display shows the fault, the car position, time and date the fault occurred and the number of occurrences. Faults are displayed in the order of occurrence with the order number displayed on the top left. The largest order number signifies the last fault that has occurred. Faults are stored in a circular

buffer that fits up to 50 faults. Once the buffer is full the next fault over writes the oldest fault. Refer to the system faults in the troubleshooting section of this manual for possible causes of the fault and a description of the detailed fault data.

5.2.7.2 CLEAR FAULT LOG

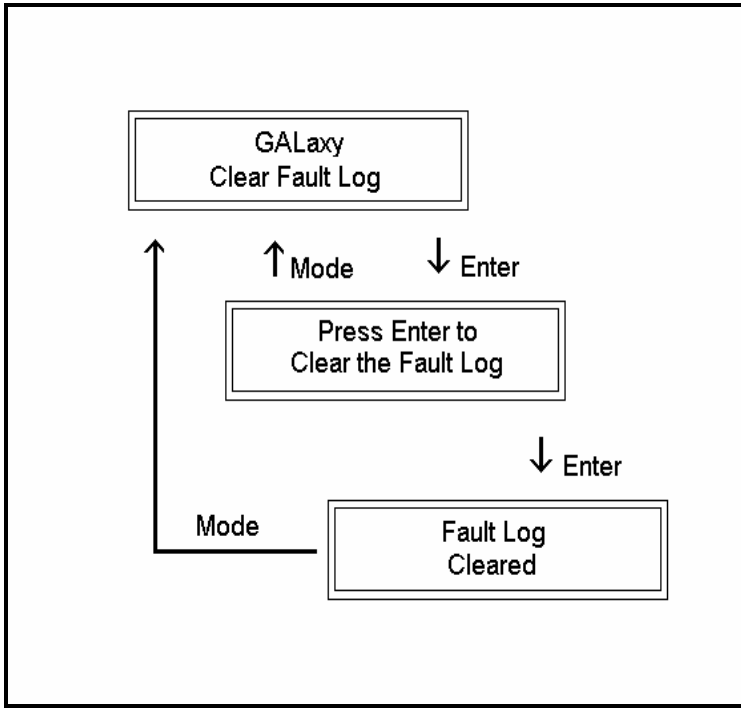

This operation clears the fault log. Once cleared, all faults will show “No Occurrences” until a new fault occurs.

5.2.8 ELEVATOR SETUP

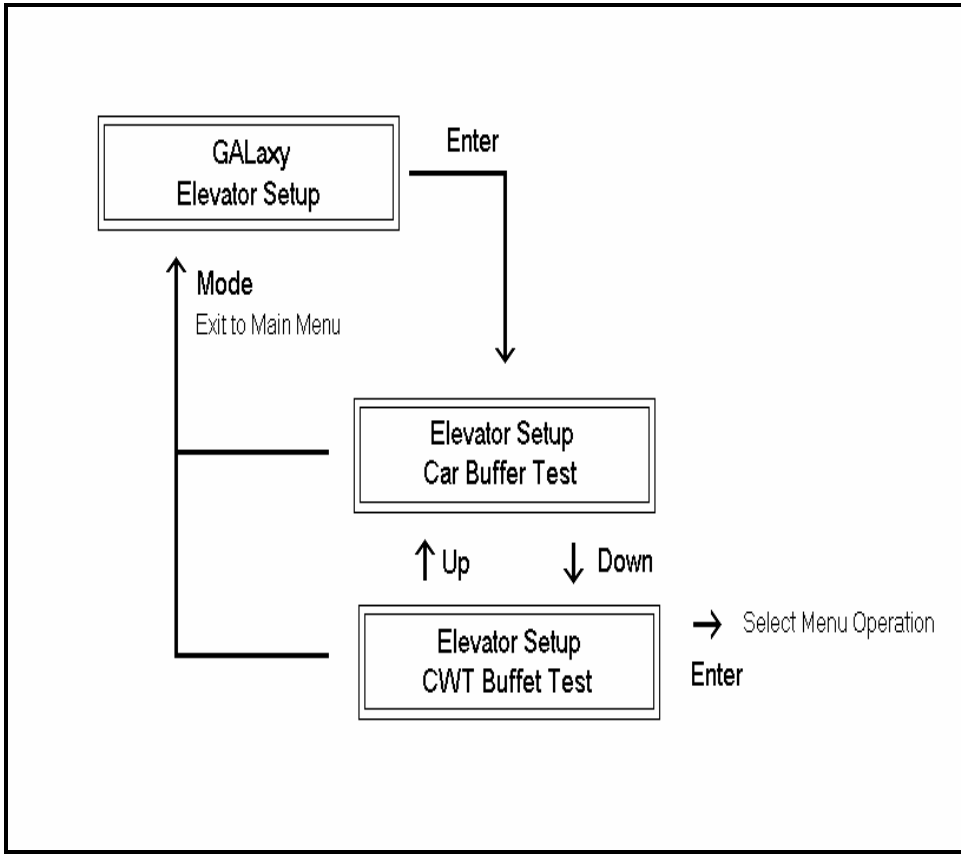

From this menu, the user can select to run a car or counterweight buffer test.

5.2.8.1 CAR AND COUNTERWEIGHT BUFFER TEST

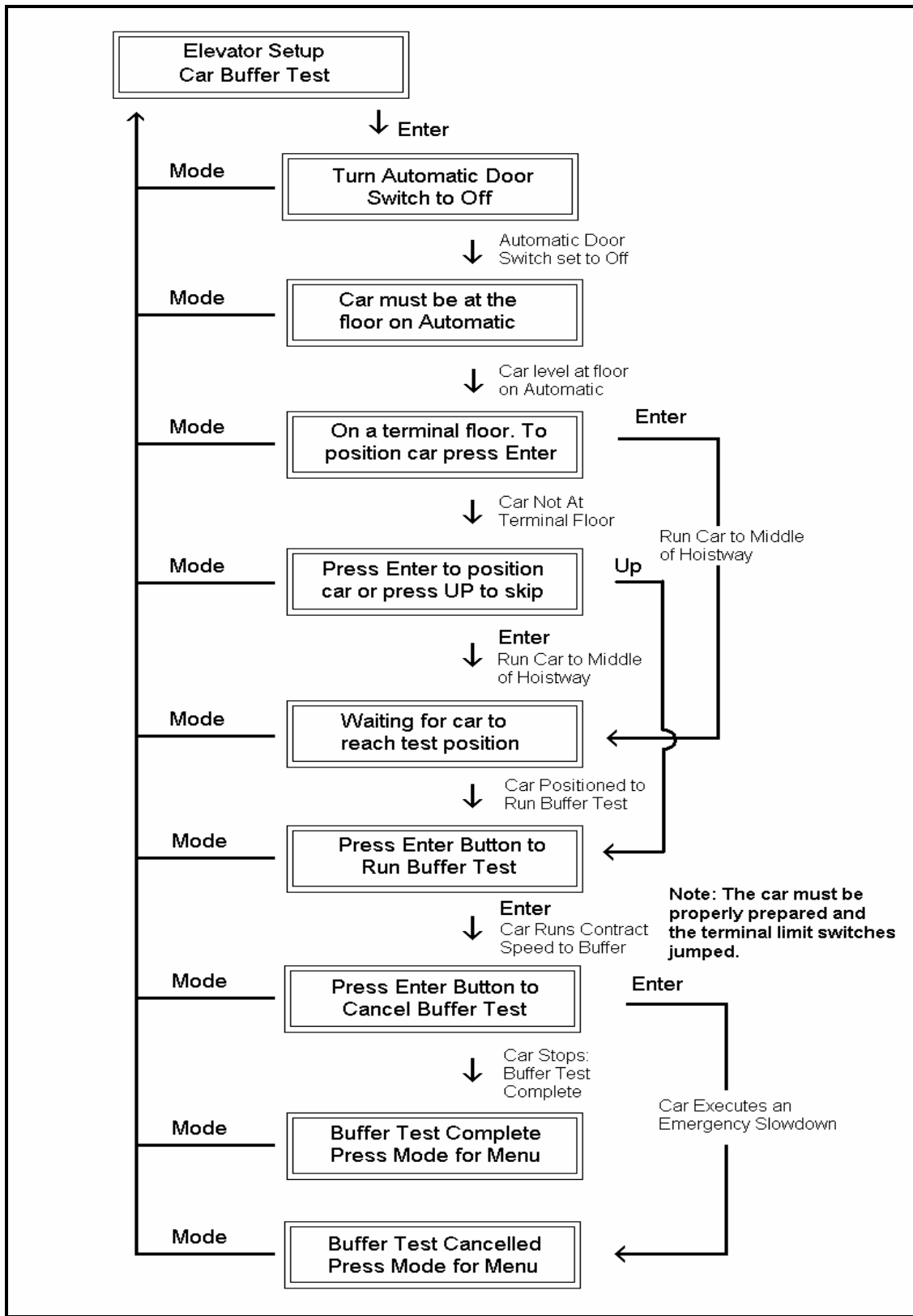

The car and counterweight buffer test follow the same menu operation. For specific instruction on executing a buffer test, refer to Appendix B.

5.2.9 SELECT VIDEO DISPLAY

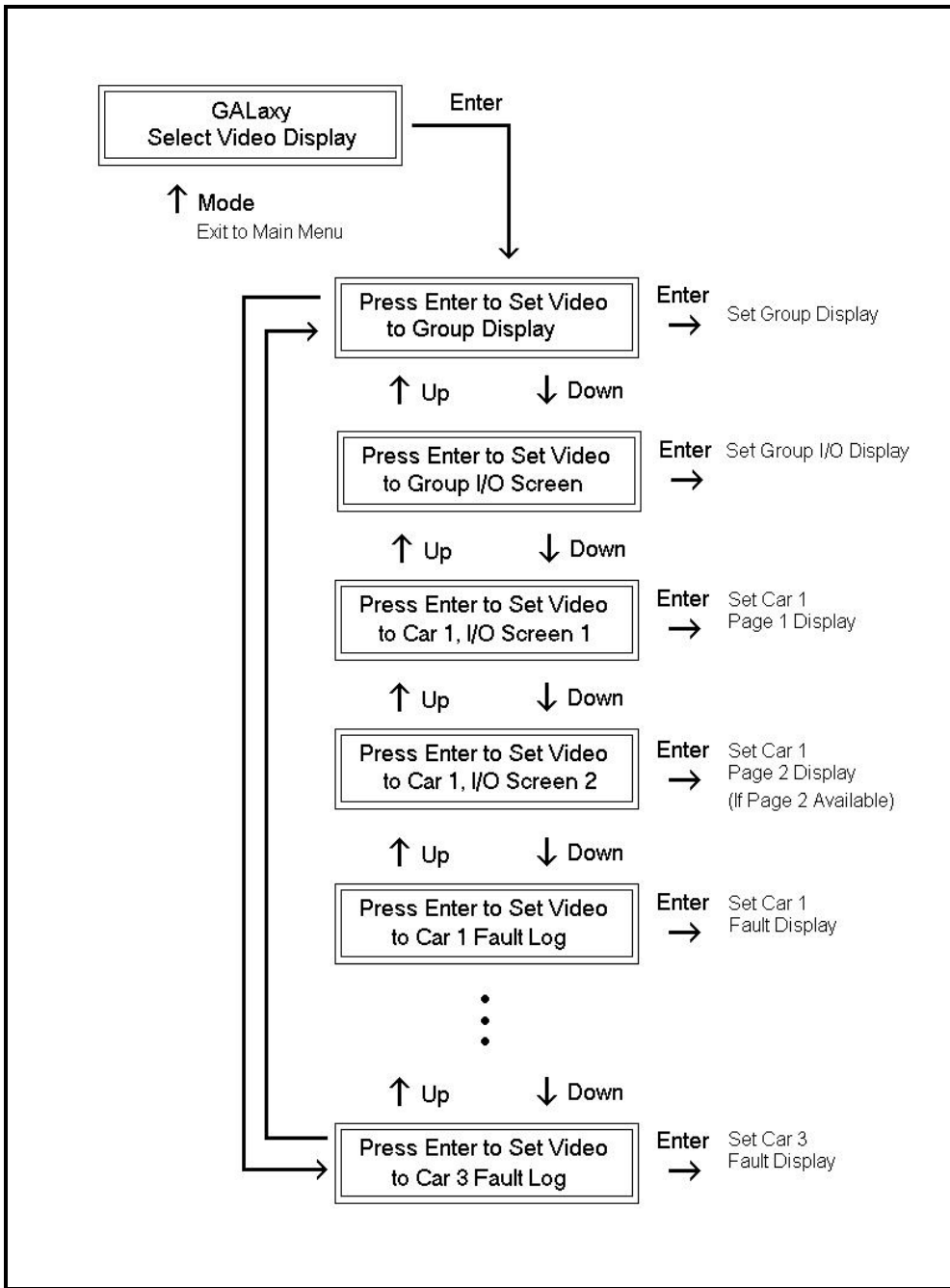

On jobs with an optional video display, this menu allows the user to change video display screen from the group display and group I/O screen to each of the car I/O and fault displays. The group I/O screen is only viewable if this is the group car and the

controller uses serial hall call boards. Depending on the number of floors, the number of car I/Os might not fit on one screen. To view the remaining I/Os, select I/O Screen 2.

5.2.10 SOFTWARE VERSION

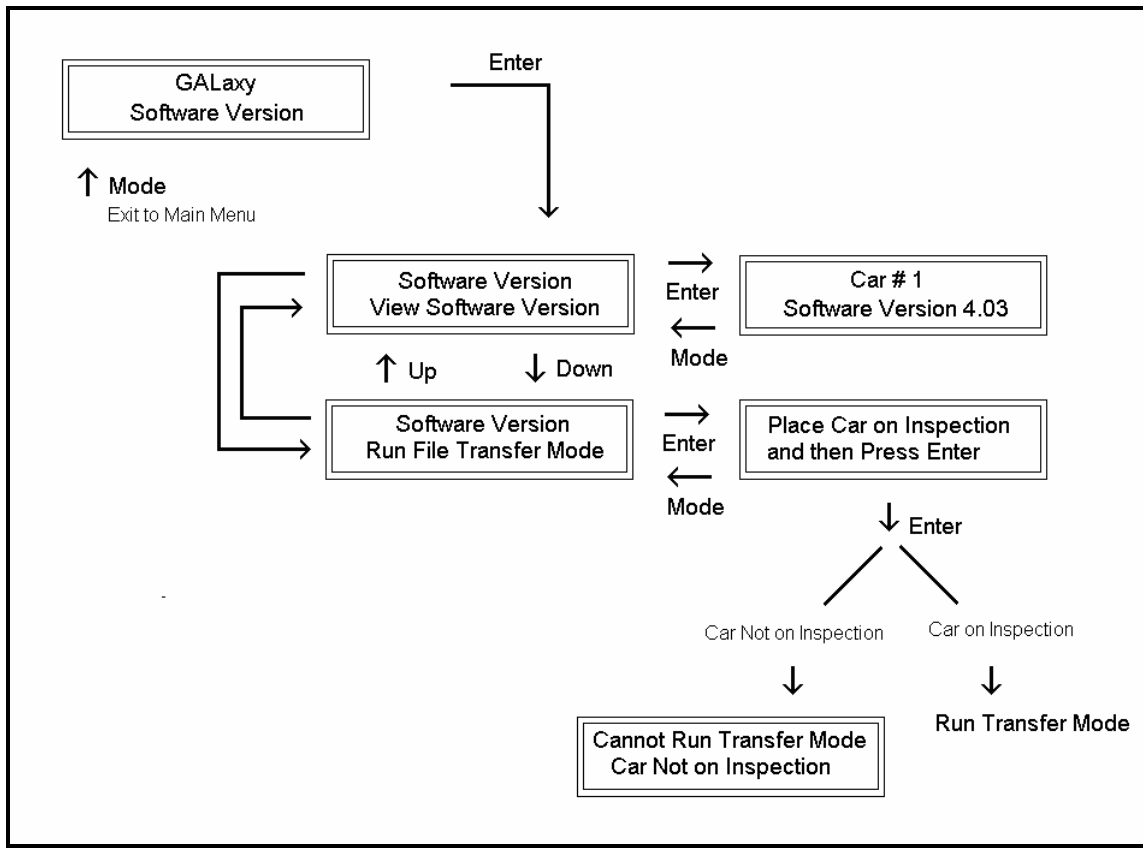

The software version menu allows the user to view the controller's software version or to place the controller in file transfer mode to upload or download the controller software to another version.

To place the car in file transfer mode, the car must be on inspection. As shown in the above diagram, the controller is programmed to be Car # 1, having software version 4.03.

5.2.11 DIAGNOSTICS

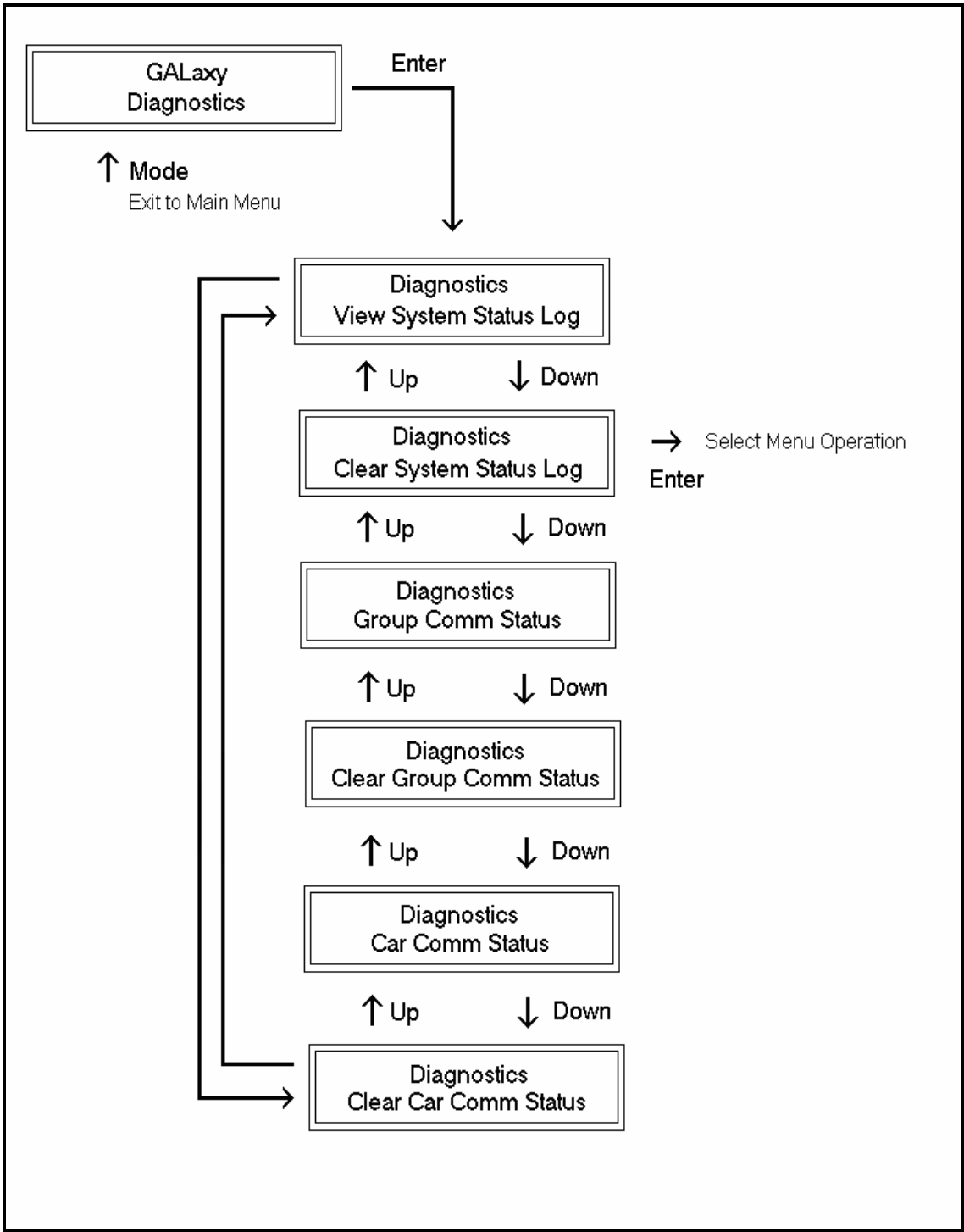

This menu allows access to diagnostic information to help troubleshoot operational or communication errors.

5.2.11.1 VIEW SYSTEM STATUS LOG

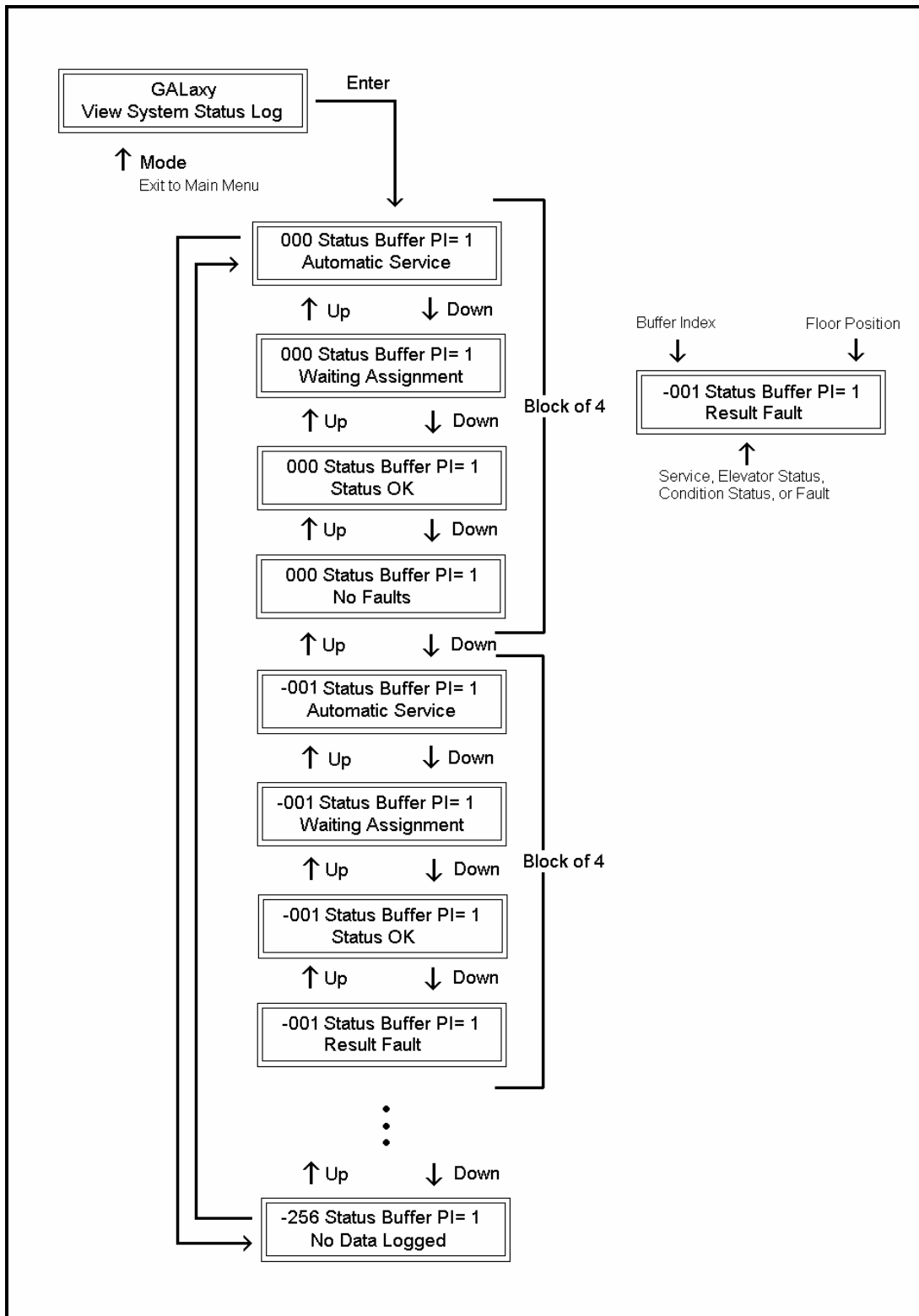

System status information is stored in a circular buffer whenever the service, elevator status or a fault occurs. This buffer holds 256 blocks of data in the sequence in which the events occur. This data can be used to debug a sequence of events that cause a fault.

The most recent block of information is always at location 000 and the event prior to the most recent is at block location -001. The event at block -002 happened before block -001 and also before block 000.

5.2.11.2 CLEAR SYSTEM STATUS LOG

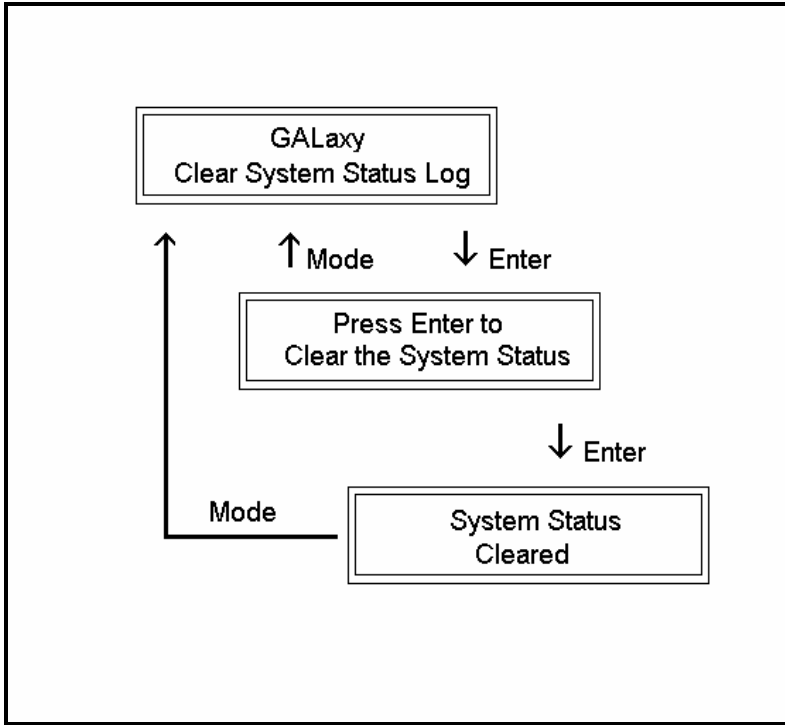

The system log can be cleared to get a new starting point. When cleared, an empty block displays “No Data Logged”.

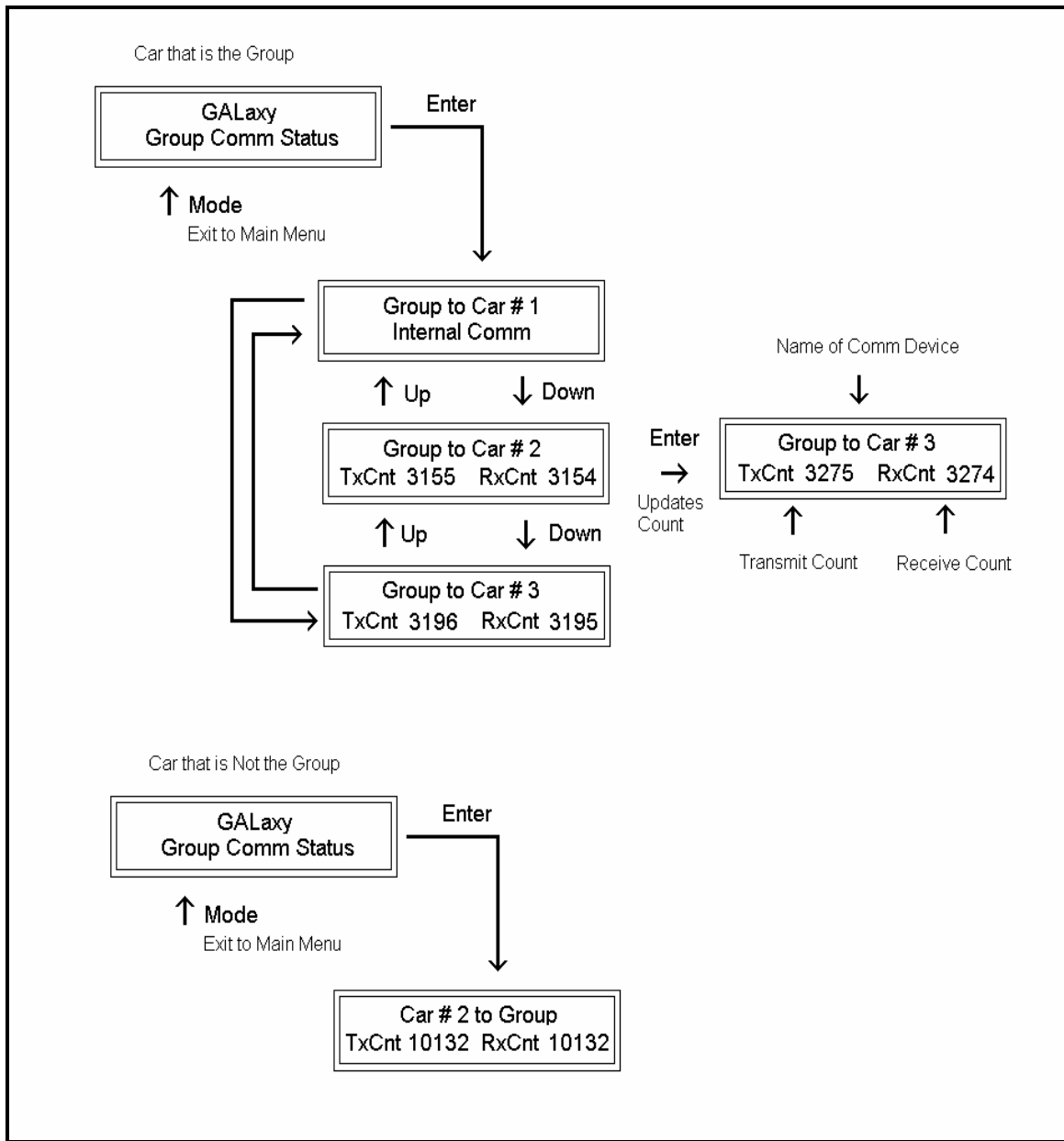

The group communications status shows the number of data packets successfully transmitted and received from the group to the cars, for the “group” car, and from the car to the group for the remaining cars. The communication sequence is always initiated by the group. The group sends a data packet to the car and after the car validates the checksum of the packet, it responds with a data packet to the group.

The transmit and receive counters should always be incrementing in both the car and the “group” car. If either counter does not increment, it would indicate a poor cable connection or that there is electrical noise on the communications cable. Electrical noise is usually caused by installing the communications cable in the same conduit with high voltage wires.

5.2.11.4 CLEAR GROUP COMM STATUS

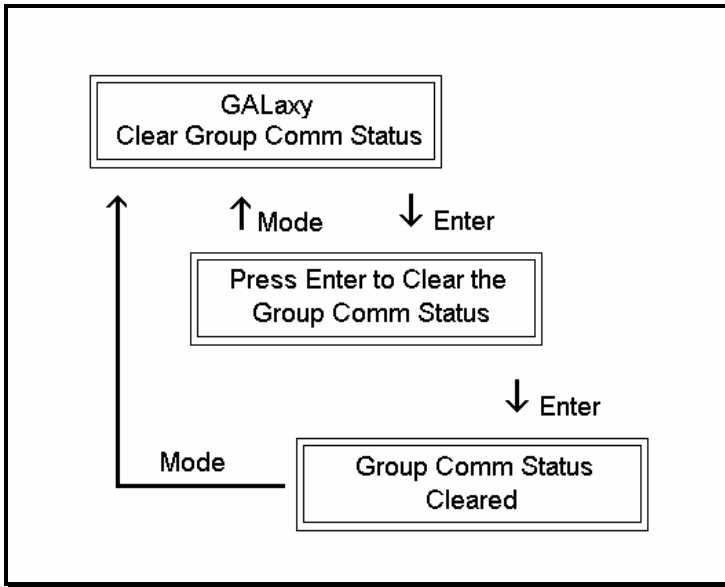

This menu is used to clear the transmit and receive counters for the group to car serial communications.

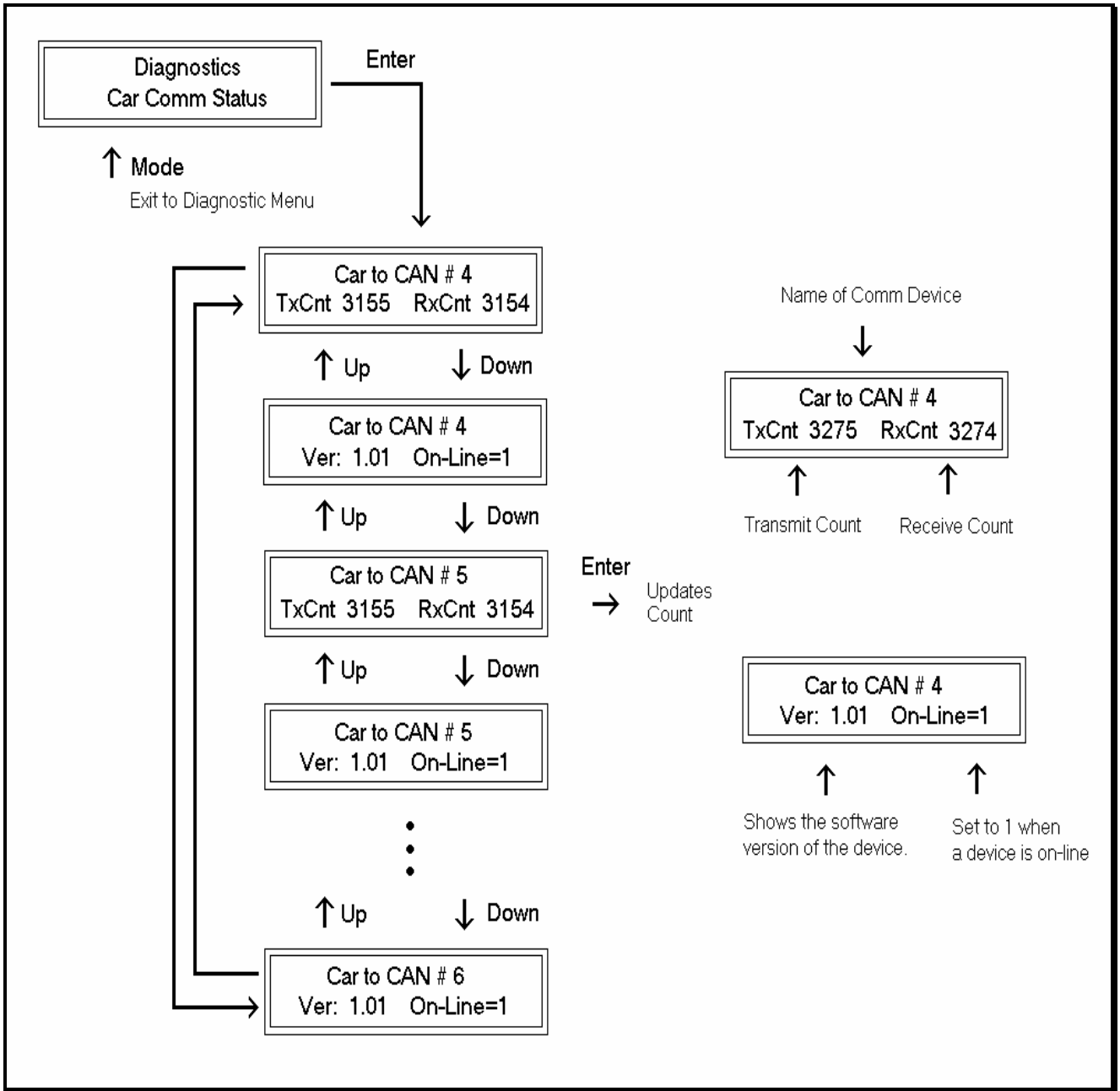

The car communications status shows the number of data packets successfully transmitted and received from the car to devices on the car's CAN bus. These devices can be mounted in the motor room, in the car operating panel or on the car top. The second line of the car status shows the device software version number and if the device is currently on line communicating.

The transmit and receive counters should always be incrementing for all devices. If the receive counter does not increment, it would indicate a poor cable connection or that there is electrical noise on the communications cable. Electrical noise is usually caused by installing the communications cable in the same conduit with high voltage wires.

5.2.11.6 CLEAR CAR COMM STATUS

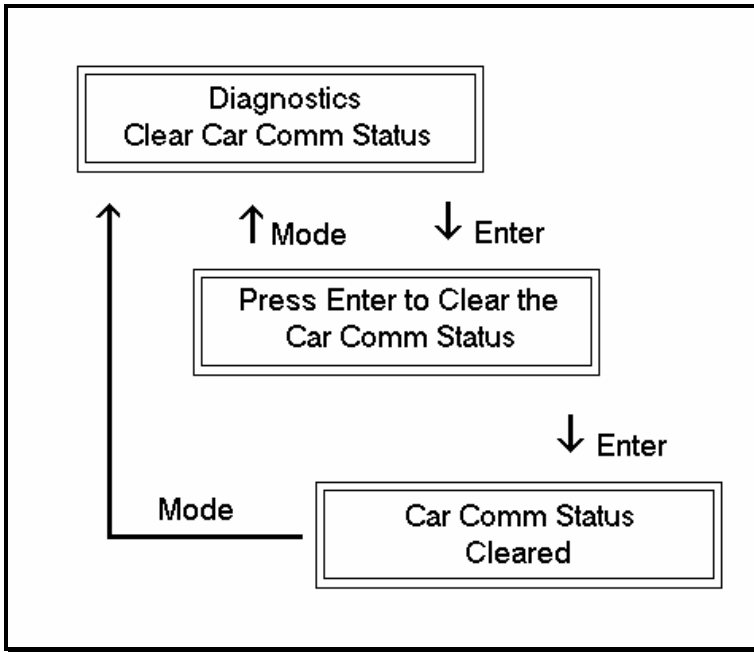

This menu is used to clear the transmit and receive counters for the car's CAN bus serial communications.

6 SAFETY PROCESSOR LCD DISPLAY INTERFACE

6.1 OPERATING THE LCD INTERFACE

SECTION 6

The Safety Processor Board LCD display interface board uses a 2 line by 8 character display and four buttons. This interface allows the user access to the internal data and operation of the Safety Processor CPU such as setup and adjustment variables, and critical control and fault information. Upon power-up, the display shows a blinking GALaxy name to indicate the board is running

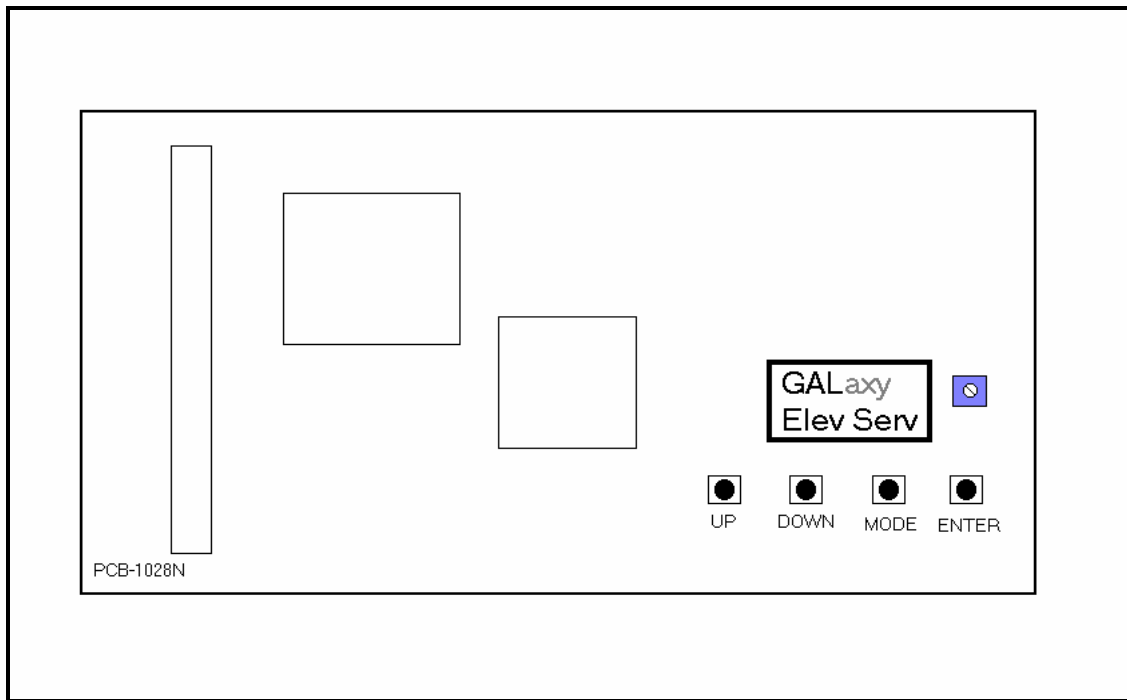

UP

UP button is used to scroll up to the next menu item or to increment a data value.



DOWN

DOWN button is used to scroll down to the next menu item or to decrement a data value.



MODE

MODE button is used to go back to the previous menu or to select a digit of a data value.



ENTER

ENTER button is used to select the menu item or to complete the operation of changing a data value.



Potentiometer is used to adjust the viewing angle. It will make the display lighter or darker.

The four inputs buttons used with the LCD display are, UP, DOWN, MODE and ENTER. The UP and DOWN buttons are used to scroll up and down to each menu item. When an appropriate menu item is reached, the ENTER button is used to select the item. Some menu items, once selected, show a second menu. Again, use the UP and DOWN buttons to scroll through the menu items and the ENTER button to select a particular

item. The MODE button is used to go back to the previous menu. When a menu item is an adjustable variable, select the item with the ENTER button and change the variable with the UP or DOWN button. The MODE button is used to move the cursor to the next digit. When the appropriate value is reached, use the ENTER button to complete the variable change operation and return to the current menu.

6.2 THE SAFETY PROCESSOR BOARD LCD MENU STRUCTURE

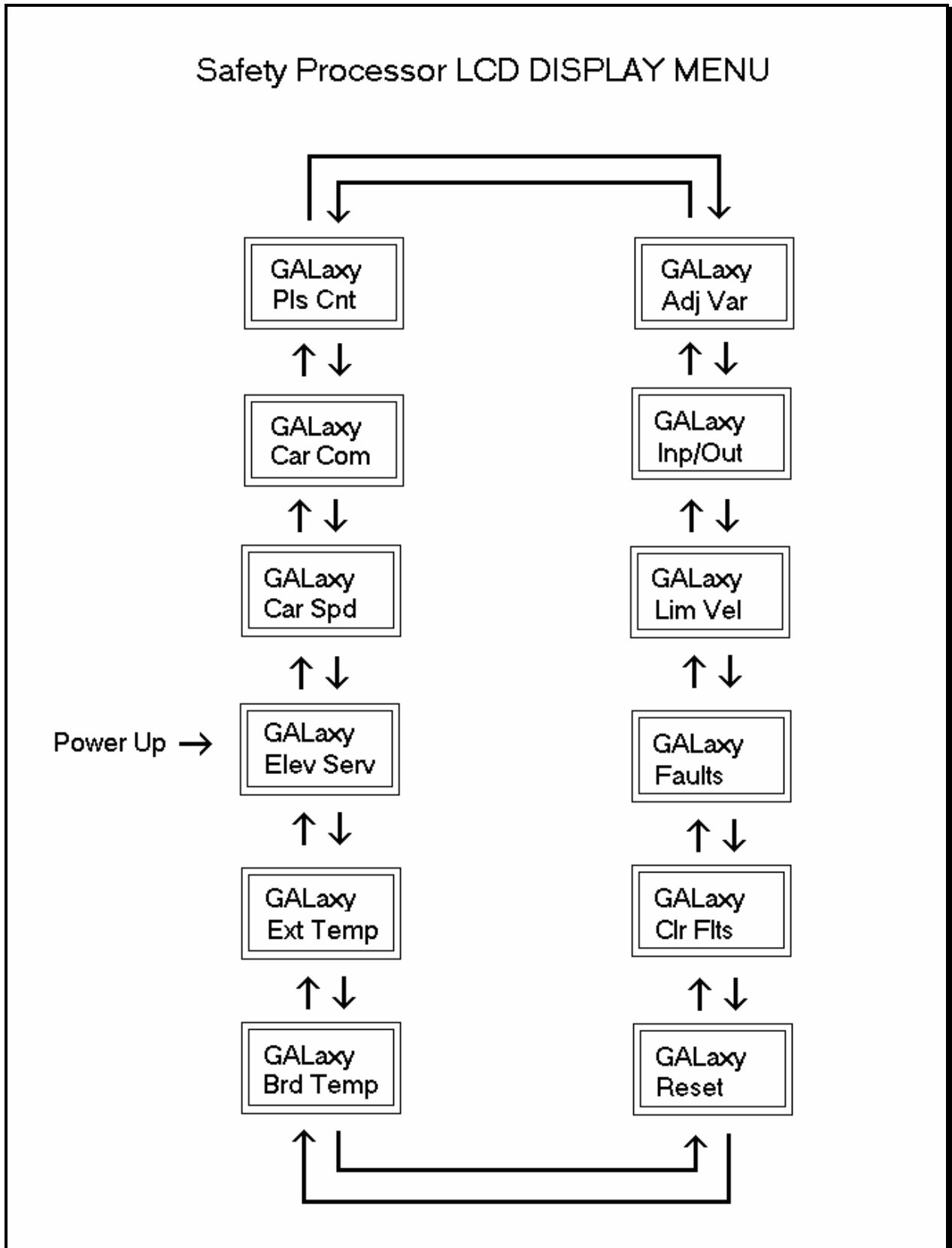

6.2.1 ELEVATOR SERVICE

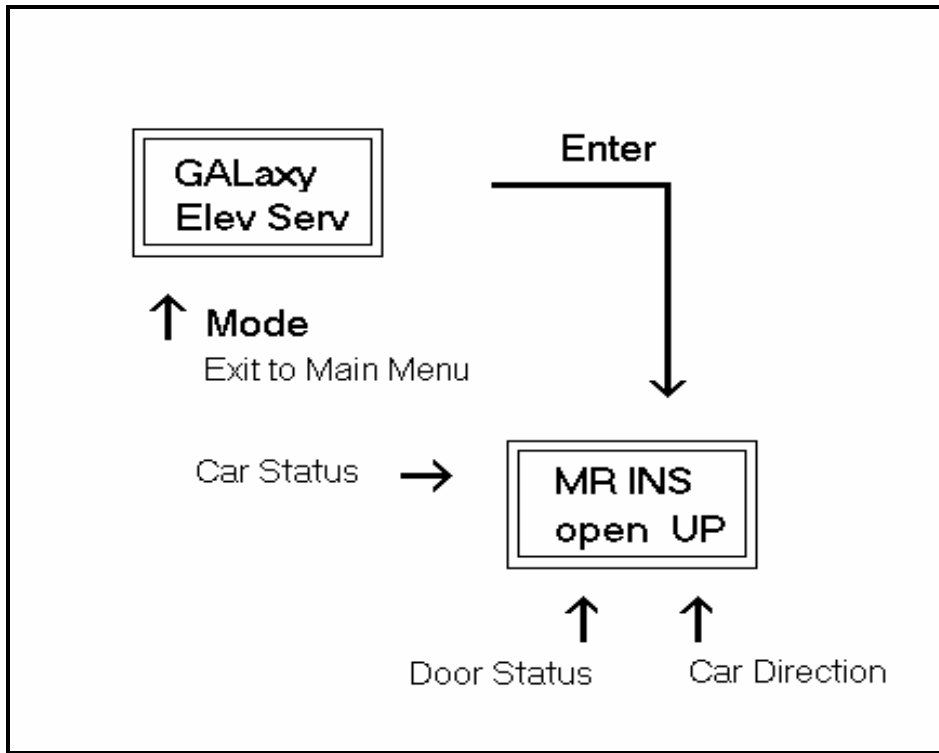

This screen shows the service the car should be on from the inspection inputs, the gate and lock bypass switch inputs and the gate and lock inputs. If any

inputs are in error, the error status is displayed. Below shows a list of what is displayed and the condition for it.

ELEVATOR SERVICE	CONDITION FOR SERVICE
AUTO	Auto input is on and all inspection inputs are off.
CT INS	Car is on car top inspection
GATE BYP	Car is on car top inspection and the gate bypass switch is on.
LOCK BYP	Car is on car top inspection and the lock bypass switch is on.
ACCESS	Car is on access operation.
MR INS	Car is on motor room inspection.
IC INS	Car is on in car inspection
INS ERR	An inspection error has occurred. There must be one and only one inspection or auto input on. All inputs are off or more than one input is on.
BYP ERR	A gate or lock bypass switch is on but the car is not on car top inspection.
VEL ERR	The car has a velocity error from inspection speed, leveling speed or a terminal slowdown speed.
UP ERR	The up output is on during power up.
DNR ERR	The down output is on during power up.
DNR/UP	Both up and down outputs are on during power up.
EEP ERR	Safety Processor board has an EEPROM error.
NO UTS	UTS input not detected at top terminal landing.
NO DTS	DTS input not detected at bottom terminal landing.

6.2.2 CAR SPEED

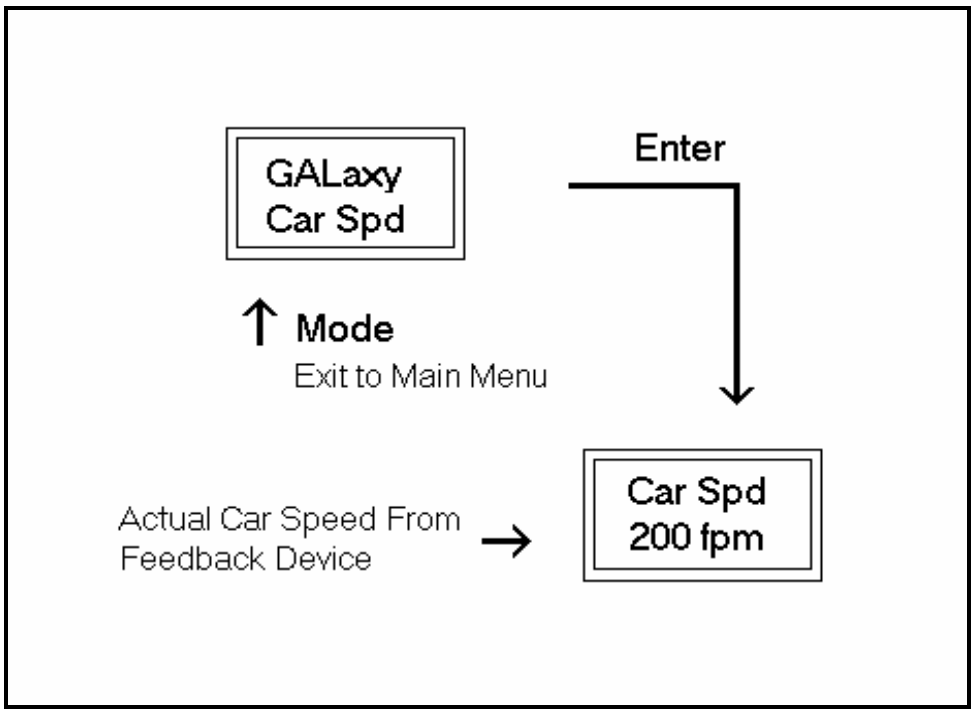

6.2.3 SAFETY PROCESSOR PULSE COUNT

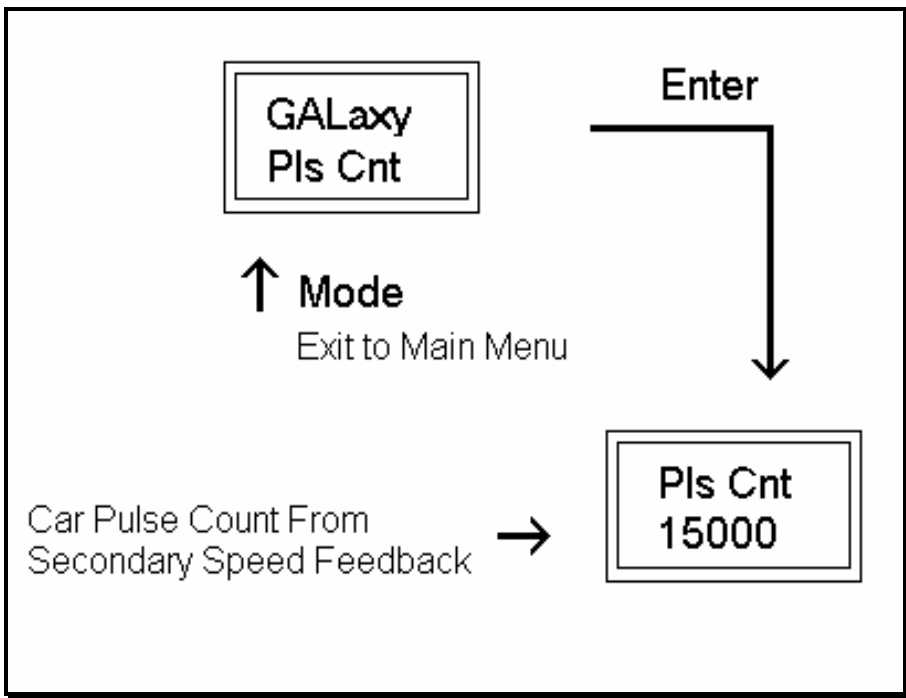

6.2.4 SAFETY PROCESSOR ADJUSTABLE VARIABLES

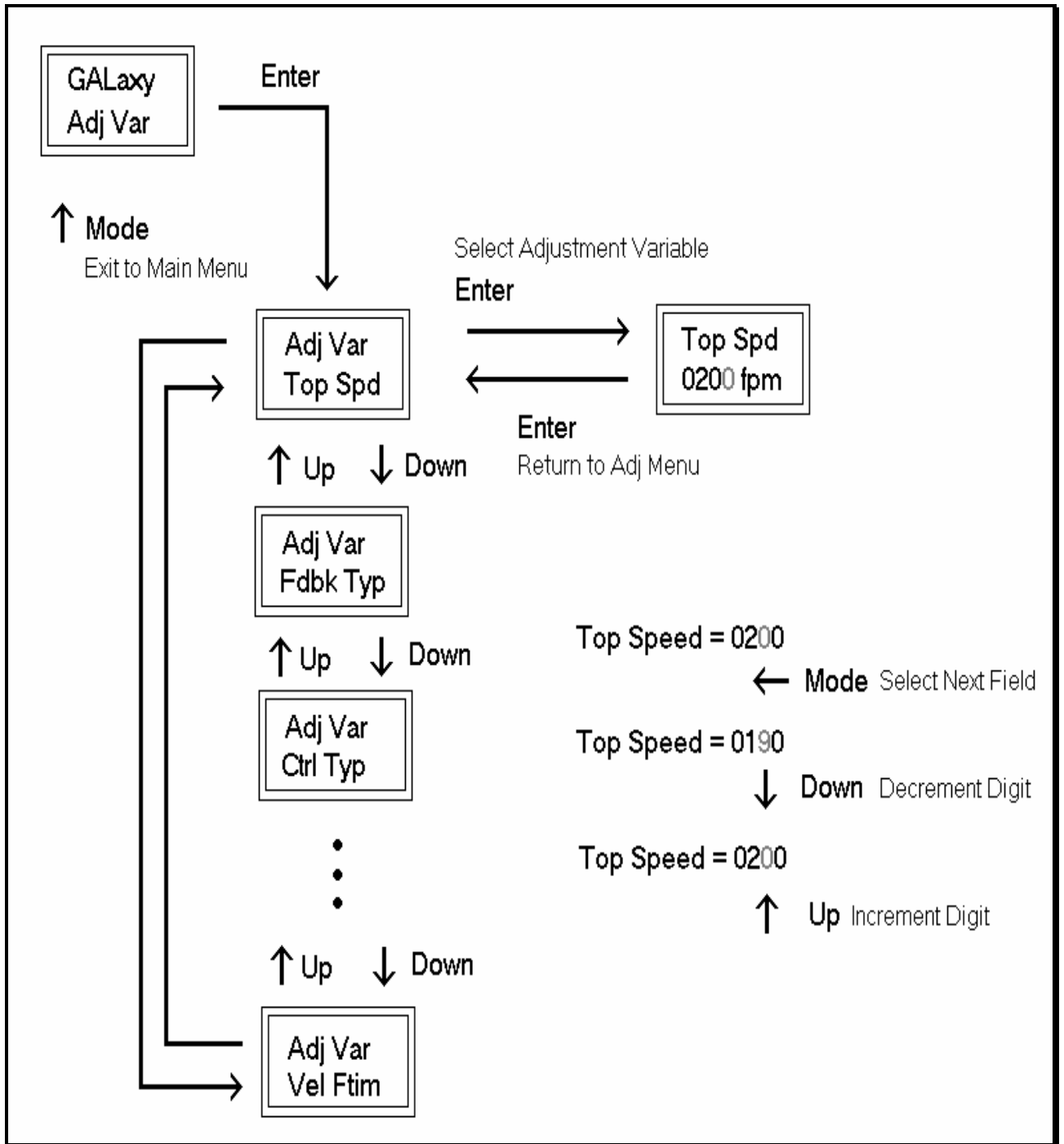

Adjustable Variables

<u>Adjustable Variable</u>	<u>Min</u>	<u>Max</u>	<u>Initial</u>	<u>Units</u>	<u>Description</u>
Top Spd	25	2000	200	Fpm	Top Speed or contract speed of the car.
Enc RPM	25	1800	1050	RPM	Encoder RPM. Revolutions per Minute of the Encoder.
Enc PPR	10	10000	2048	PPR	Encoder PPR. Pulses Per Revolution of the Encoder.
Fdbk Typ	0	2	0	–	Feedback Type. Type of feedback used by the Safety Processor to calculate the car's velocity. 0=Tape, 1=Encoder.
Ctrl Typ	0	2	0	–	Control Type. Type of controller used. 0=Hydro, 1=Traction Non-Distance Feedback, 2=Traction Distance Feedback.
2 Stop	0	1	0	–	2 Stop. Set to 1 if this car travels to only two landings. This parameter tells the Safety Processor that there are no middle door locks.
RearDoor	0	1	0	–	Rear Door. Indicates that the car has rear doors and the Safety Processor should verify the rear door gate and locks.
UTS Vel	0	1000	200	Fpm	Up Emergency Terminal Slowdown Velocity. Maximum velocity to hit the up terminal slowdown limit. Hitting the limit at a higher velocity will cause the Safety Processor board to shut the car down from a velocity error. For cars with speeds greater than 200 fpm.
DTS Vel	0	1000	200	Fpm	Down Emergency Terminal Slowdown Velocity. Maximum velocity to hit the down terminal slowdown limit. Hitting the limit at a higher velocity will cause the Safety Processor board to shut the car down from a velocity error. For cars with speeds greater than 200 fpm.
INS Vel	0	200	140	Fpm	Inspection Velocity. Maximum velocity the car is allowed to run on inspection.
LEV Vel	0	200	140	Fpm	Leveling Velocity. Maximum velocity the car is allowed to run while leveling with the door open.
UT Vel	0	500	200	Fpm	Up Terminal Slowdown Velocity. Maximum velocity to hit the up terminal slowdown "software" limit. The software limit is set when the car hits the UT limit then travels the UT Counts closer to the terminal. Hitting the limit at a higher velocity than set by this parameter will cause the Safety Processor board to shut the car down from a velocity error.
DT Vel	0	500	200	Fpm	Down Terminal Slowdown Velocity. Maximum velocity to hit the down terminal slowdown "software" limit. The software limit is set when the car hits the DT limit then travels the DT Counts closer to the terminal. Hitting the limit at a higher velocity than set by this parameter will cause the Safety Processor board to shut the car down from a

<u>Adjustable Variable</u>	<u>Min</u>	<u>Max</u>	<u>Initial</u>	<u>Units</u>	<u>Description</u>
					velocity error.
UT Count	0	2000	12	Pulse Counts	Up Terminal Count. The number of counts after the UT limit is hit traveling toward the terminal landing for the UT software limit to become active. On cars with only one slowdown limit, the car would normally hit the limit at top speed during a recovery run. The UT Count allows the car time to slowdown before the Safety Processor can shut the car down from a limit velocity error.
DT Count	0	2000	12	Pulse Counts	Down Terminal Count. The number of counts after the DT limit is hit traveling toward the terminal landing for the DT software limit to become active. On cars with only one slowdown limit, the car would normally hit the limit at top speed during a recovery run. The DT Count allows the car time to slowdown before the Safety Processor can shut the car down from a limit velocity error.
Dmd Mult	0.5	1.5	1	–	Demand Multiplier. Multiplies the analog to digital input of the car's demand velocity. Increase or decrease the multiplier to display the exact speed of the car on the Car Demand screen.
SoftStop	1	10	1	Sec	Soft Start Timer. During a soft stop, the speed command is brought to zero, then the brake is dropped and finally the run outputs are turned off. This timer is used to keep the run outputs from timing out during a soft stop.
Pls Ftim	0	5.00	2.00	Sec	Pulse Count Fault Delay Time. Time delay to detect that the selector pulses have stopped.
Vel Ftim	0	0.500	0.180	Sec	Velocity Fault Delay Time. Time delay after a velocity fault to shut the car down.

6.2.5 SAFETY PROCESSOR INPUTS AND OUTPUTS

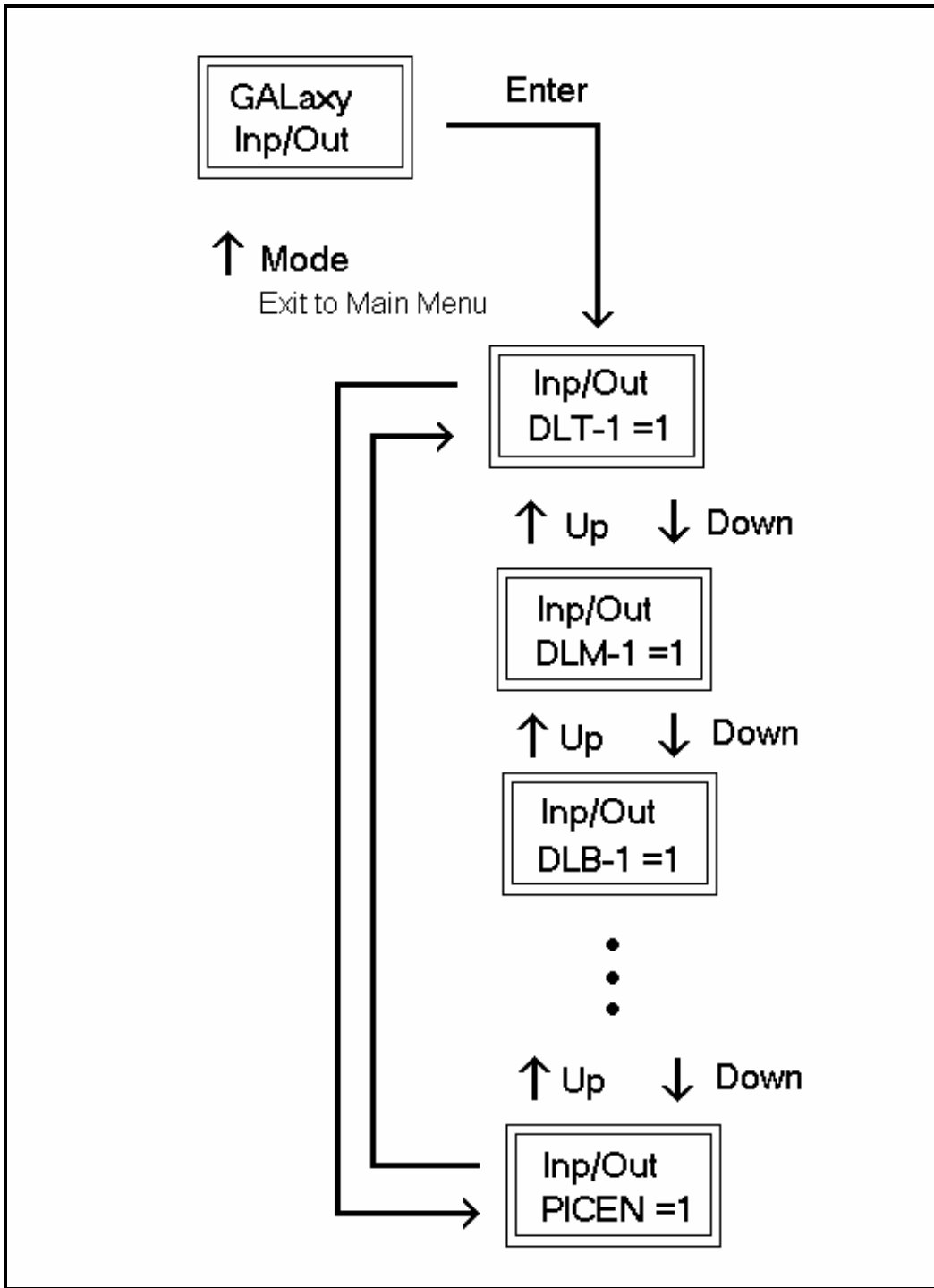

This display shows all the inputs and outputs of the Safety Processor. The following table shows the name description for each I/O.

NAME	DESCRIPTION
DLT-1	Door Lock Top Secondary Input. Input equals 1 when the top door lock is made.
DLM-1	Door Lock Middle Secondary Input. Input equals 1 when the middle door locks are made.
DLB-1	Door Lock Bottom Secondary Input. Input equals 1 when the bottom door lock is made.
GS-1	Gate Switch Secondary Input. Input equals 1 when the front door gate switch is made.
RLM-1	Rear Lock Middle Input. Input equals 1 when the rear middle locks are made.
RGS	Rear Gate Switch. Input equals 1 when the rear door gate switch is made.
GBP	Gate Bypass. This is the input from the gate bypass switch. 1=bypass switch is on.
LBP	Lock Bypass. This is the input from the lock bypass switch. 1=bypass switch is on.
MRI	Motor Room Inspection. Input equals 1 when the car is on motor room inspection.
CTI	Car Top Inspection. Input equals 1 when the car is on car top inspection.
ACC	Access. Input equals 1 when the car is on access operation.
ICI	In Car Inspection. Input equals 1 when the car is on in-car inspection operation.
AUTO	Auto Input. Input equals 1 when the car is on automatic operation.
UL-1	Up Level Secondary Input. Input from the selector that the car is on the up level sensor in the door zone.
DL-1	Down Level Secondary Input. Input from the selector that the car is on the down level sensor in the door zone.
UP	Up Run Output. Output from the main CPU when the car is running up.
DNR	Down Run Output. Output from the main CPU when the car is running down.
UTS	Up Emergency Terminal Slowdown. Input goes low when the car is on the up emergency terminal slowdown limit.
DTS	Down Emergency Terminal Slowdown. Input goes low when the car is on

NAME	DESCRIPTION
	the down emergency terminal slowdown limit.
UT	Up Terminal Slowdown. Input goes low when the car is on the up terminal slowdown limit.
DT	Down Terminal Slowdown. Input goes low when the car is on the down terminal slowdown limit.
LSCS	Leveling Speed Control. Output comes on when the car is traveling less than 150 fpm.
SFCO	Safety Fault Control Output. Output must be on to energize the SFC relay. When this relay is dropped out, the safety string will be opened.
PICEN	PIC Enable. The Safety Processor uses a PIC CPU. This is the enable line to the PAL device that allows the run outputs from main CPU. 1=OK to run.

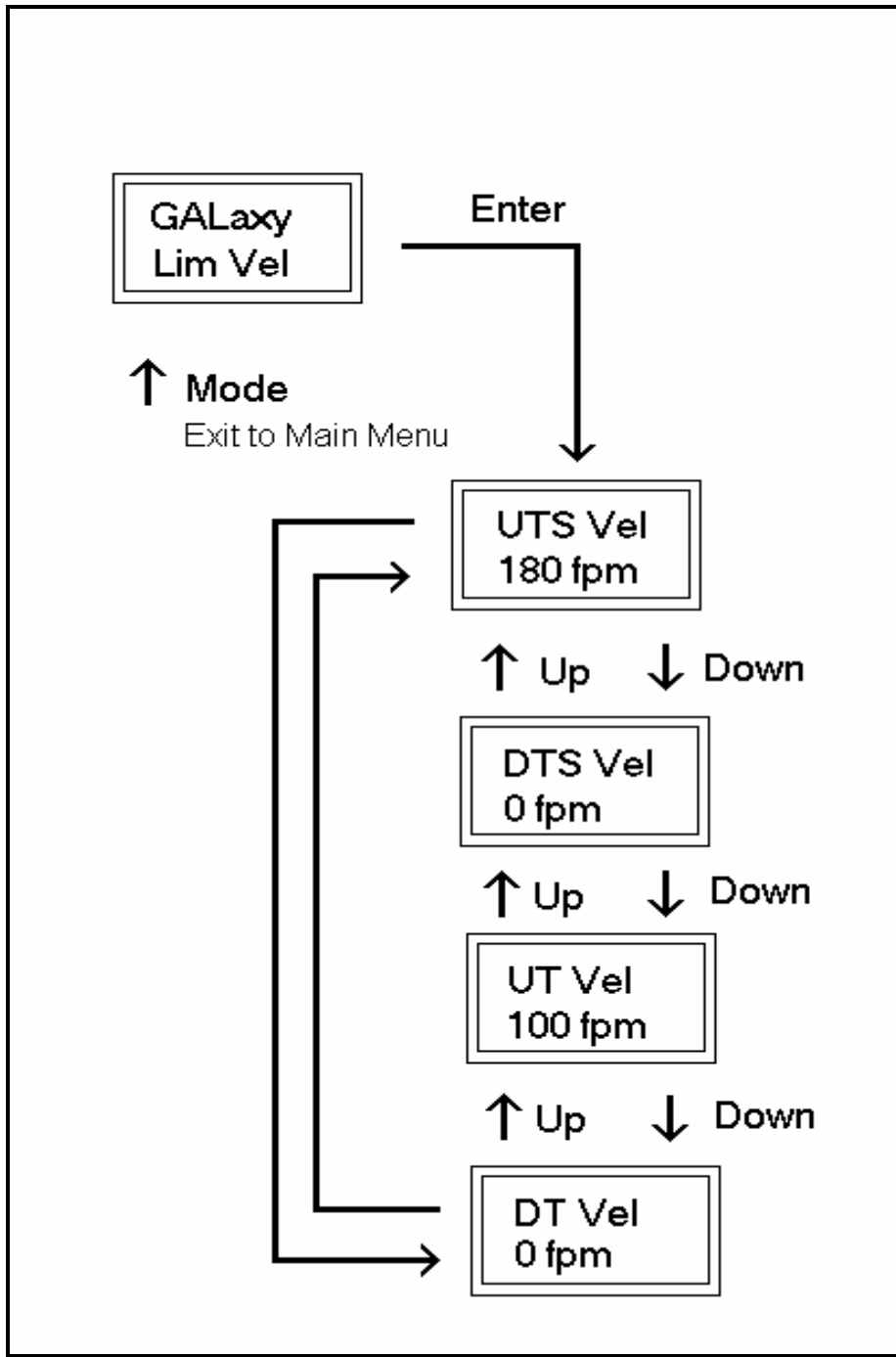

Each time the car hits a limit while running, the velocity for that limit is stored in ram and can be displayed. This velocity value is cleared on a run in the opposite direction.

This display is used to setup the slowdown velocity adjustable variables. Once the car is running on

automatic, send the car to the terminal limit and record the velocity value after the car stops. Start with a one-floor run and increase the distance of the run by one floor until the car reaches top speed. Use the highest velocity value for that limit as the adjustable variable value.

6.2.7 SAFETY PROCESSOR FAULTS

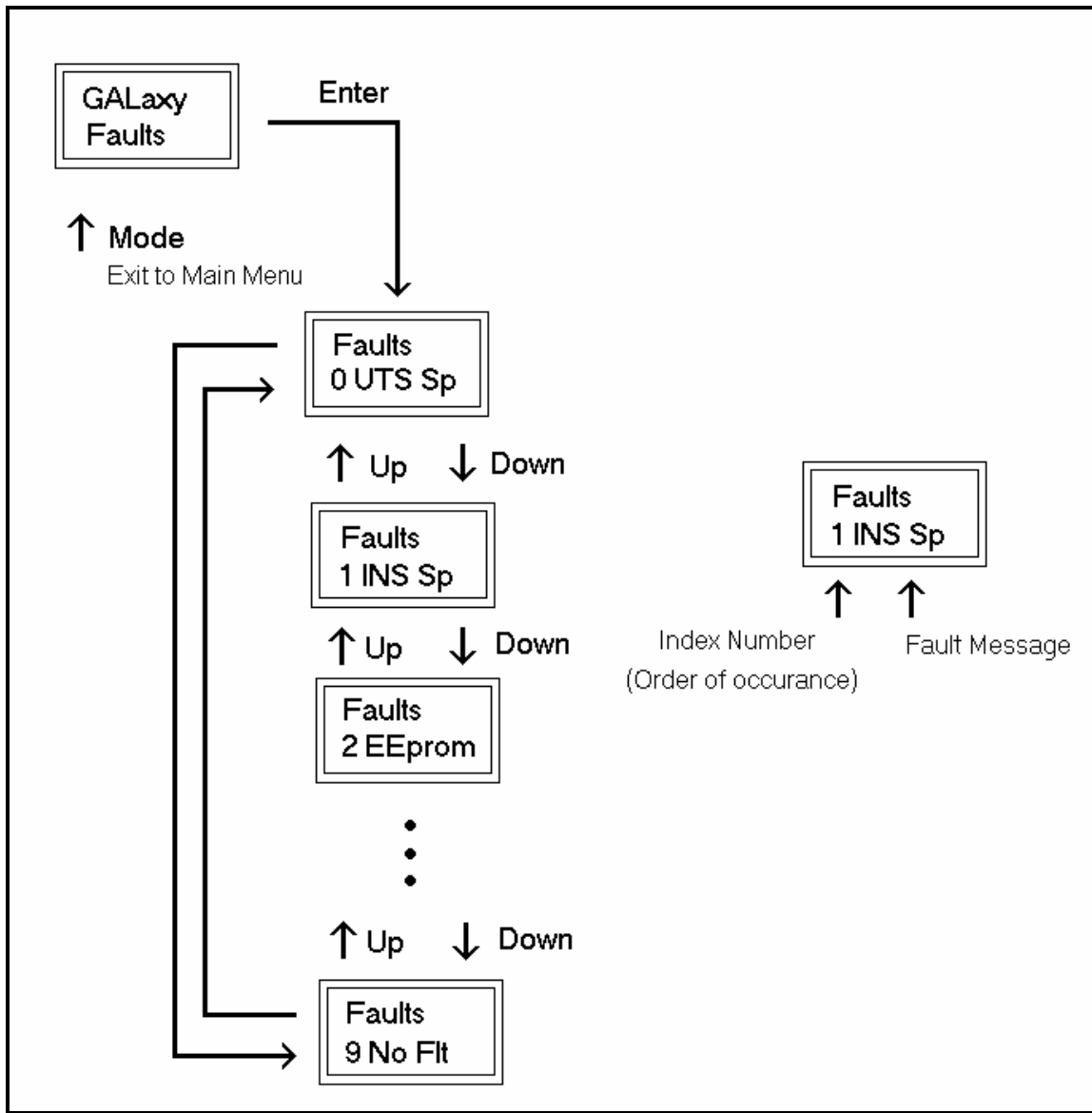

Faults are displayed in the order that they occur with index 0 being the most recent. In the figure above, an EEprom fault occurred followed by an Inspection Speed fault followed by a UTS Speed fault. Any index location that does not yet contain a fault will show No Flt.

There are 10 fault locations all of which are cleared on power up or from the clear fault menu. Below is a list of faults and their causes.

FAULT	DESCRIPTION AND CAUSE
No Flt	No fault is recorded in this index location.
Invalid	Invalid fault number. (This can only be caused by a programming error in the chip).
EEprom	EEprom fault. Defective EEPROM device or EEPROM device is not installed. The car will not be able to run until the EEPROM is installed or replaced.
UTS Sp	UTS Speed Fault. The car hit the UTS limit at a higher velocity than the value set for the UTS Velocity adjustable variable. The car will immediately shut down.
DTS Sp	DTS Speed Fault. The car hit the DTS limit at a higher velocity than the value set for the DTS Velocity adjustable variable. The car will immediately shut down.
UT Spd	UT Speed Fault. The car hit the UT limit at a higher velocity than the value set for the UT Velocity adjustable variable. The car will immediately shut down.
DT Spd	DT Speed Fault. The car hit the DT limit at a higher velocity than the value set for the DT Velocity adjustable variable. The car will immediately shut down.
INS Sp	Inspection Speed Fault. The car exceeded the INS Velocity adjustable variable while running on inspection. The car will immediately shut down.
LEV Sp	Leveling Speed Fault. The car exceeded the LEV Velocity adjustable variable while leveling with a door open. The car will immediately shut down.
DL/GS	Door Lock/Gate Switch Fault. Car is moving outside the door zone with the door open. The car will immediately shut down.
IO Flt	<p data-bbox="540 1434 1369 1497">I/O Fault. An input is on in error. The Elev Serv display will show the I/O error. Possible causes are as follows:</p> <ol data-bbox="589 1535 1369 1801" style="list-style-type: none"> <li data-bbox="589 1535 1190 1566">5. All inspection inputs and the auto input are off. <li data-bbox="589 1604 1369 1635">6. More than one inspection or auto input is on at the same time. <li data-bbox="589 1673 1369 1705">7. A bypass input is on while the car is not on Car top inspection. <li data-bbox="589 1743 1369 1801">8. Both up and down run output from the main CPU are on at the same time. <p data-bbox="589 1839 1235 1871">The car will not be able to run until the error is cleared.</p>

FAULT	DESCRIPTION AND CAUSE
INS DO	Inspection Door Open Fault. A door is open while running on inspection and the gate and locks are not being bypassed. The car will immediately shut down.
Pls Er	<p>Pulse Error. Not enough pulses have occurred during the Pulse Fault Time period. This error is detected only on automatic operation. Verify that the pulse LED on the Safety Processor board blinks while the car is running on inspection. Possible causes are as follows:</p> <ol style="list-style-type: none"> <li data-bbox="634 485 1373 552">5. Improper connection for PP and PPS. Refer to the job specific prints. <li data-bbox="634 590 1203 621">6. PP and PPS field wires need to be swapped. <li data-bbox="634 659 1284 690">7. Photocoupler in selector is faulty. Call the Factory. <li data-bbox="634 728 1373 827">8. Voltage from PP to 0V on the Safety Processor Board is less than 10 VDC with the PP and PPS wires disconnected. Call the Factory.

6.2.8 CLEAR FAULTS

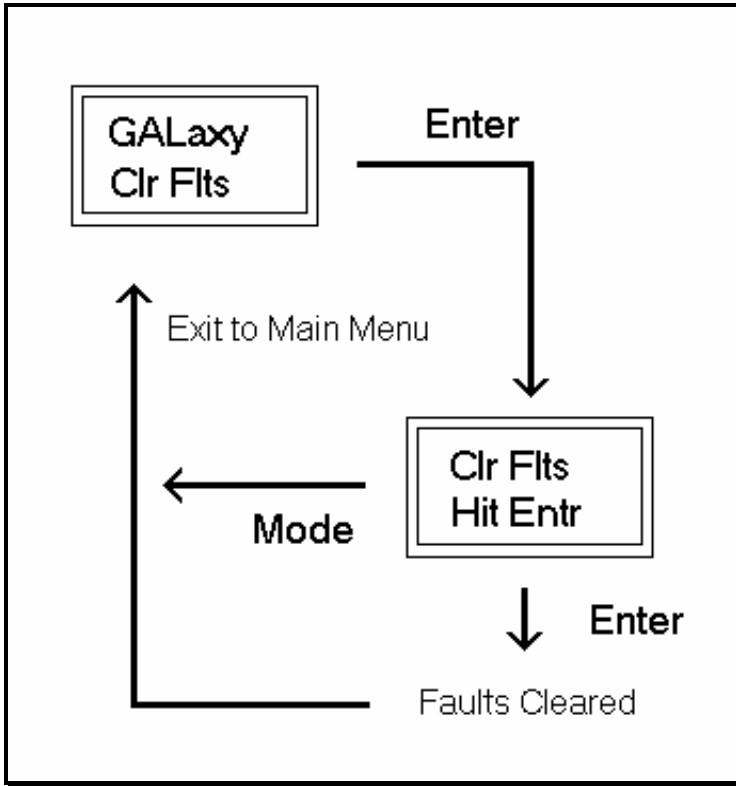

6.2.9 RESET SAFETY PROCESSOR FAULT LATCH

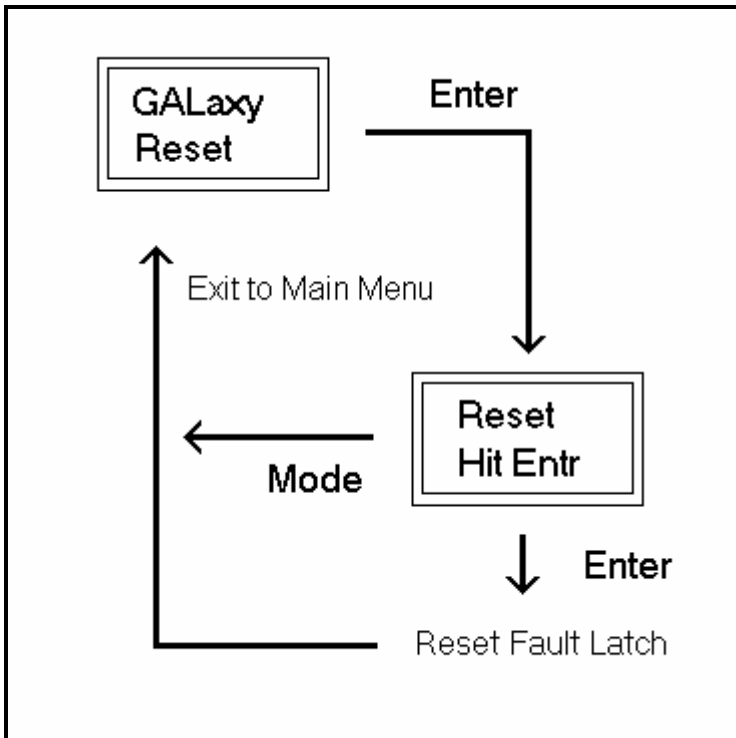

6.2.10 SAFETY PROCESSOR BOARD TEMPERATURE

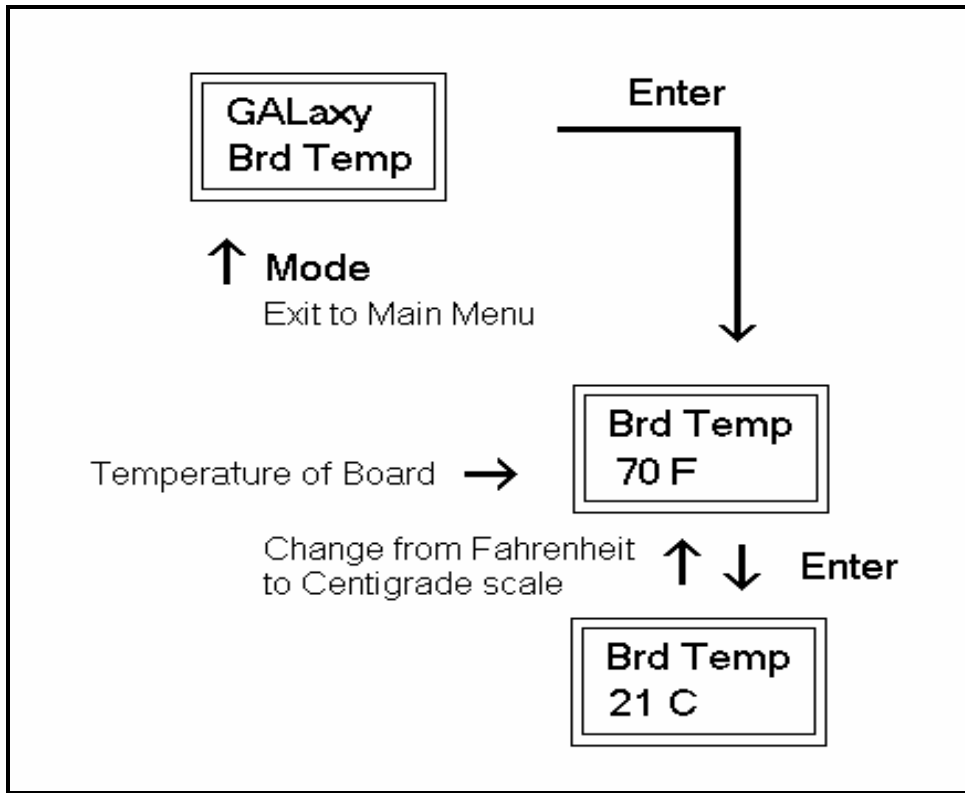

6.2.11 EXTERNAL TEMPERATURE

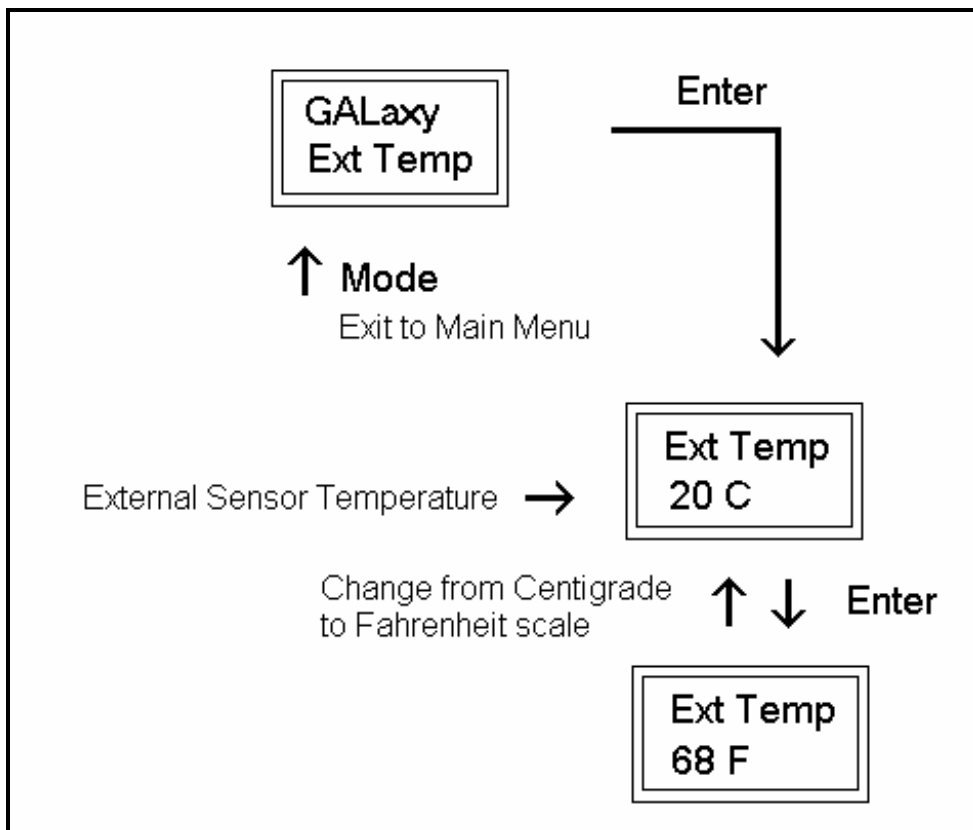

Appendix A

Description of I/O Mnemonics

Mnemonic	I/O Name
1C-29C	1 st – 29 th Floor Car Call Inputs
1CA-29CA	1 st – 29 th Floor Car Call Acknowledge Outputs
1CAR-29CAR	1 st – 29 th Floor Rear Car Call Acknowledge Outputs
1CR-29CR	1 st – 29 th Floor Rear Car Call Inputs
1U-28U	1 st – 28 th Floor Up Hall Call Inputs
1UA-28UA	1 st – 28 th Floor Up Hall Call Acknowledge Outputs
1UAR-28UAR	1 st – 28 th Floor Rear Up Hall Call Acknowledge Outputs
1UR-28UR	1 st – 28 th Floor Rear Up Hall Call Inputs
2D-29D	2 nd – 29 TH Floor Down Hall Call Inputs
2DA-29DA	2 nd – 29 th Floor Down Hall Call Acknowledge Outputs
2DAR-29DAR	2 nd – 29 th Floor Rear Down Hall Call Acknowledge Outputs
2DR-29DR	2 nd – 29 TH Floor Rear Down Hall Call Inputs
ACC	Access Operation Input.
AD	Automatic Door Switch Input
AD0-AD11	Analog to Digital Input Data
ALT	Alternate Fire Smoke Detector Sensor Input
ATT	Attendant Operation Input.
ATTDN	Attendant Down Input.
ATTUP	Attendant Up Input.
AUTO	Automatic Operation Input.
B16	Binary Position Sensor 16 Input
BAD	Bottom Access Down Input.
BAU	Bottom Access Up Input.
BKC	Brake Cool Pilot Output
BKS	Brake Switch Input
BP	Fire Phase I Smoke Detector Bypass Input
BP1	Binary Position Sensor 1 Input
BP2	Binary Position Sensor 2 Input
BP4	Binary Position Sensor 4 Input
BP8	Binary Position Sensor 8 Input
BRK	Brake Pilot Output
BRKI	Brake Control Input.
CAR	Car number
CDL	Cab Down Lantern Output
CNV	DAC Convert Output
COL	Counter Weight Collision Switch Input (Traction Elevators)
CS	In Car Stop Switch Input
CUL	Cab Up Lantern Output
DA0-DA7	Digital to Analog Output Data
DC	Door Close Output
DCB	Door Close Button Input
DCBR	Door Close Button Rear Input
DCC	DAC Clear Output
DCL	Door Close Limit Input

<u>Mnemonic</u>	<u>I/O Name</u>
DCLR	Door Close Limit Rear Input
DCR	Door Close Rear Output
DCS	DAC Chip Select Output
DDA	Down Direction Arrow Output
DEL	Delta Relay Input
DF	Down Fast Pilot Output
DFI	Down Fast Input
DL	Down Level Sensor Input
DL-1	Down Level Sensor Secondary Input.
DLB	Door Lock Bottom Input.
DLB-1	Door Lock Bottom Secondary Input
DLM	Door Lock Middle Input
DLM-1	Door Lock Middle Secondary Input
DLT	Door Lock Top Input.
DLT-1	Door Lock Top Secondary Input.
DN	Down Normal Limit Input
DNI	Down Relay Input
DNI	Down Run Input.
DNR	Down Pilot Output
DO	Door Open Output
DOB	Door Open Button Input
DOBR	Door Open Button Rear Input
DOL	Door Open Limit Input
DOLR	Door Open Limit Rear Input
DON	Drive On.
DOR	Door Open Rear Output
DPR	Door Protect Relay Input
DS	Down Slowdown Sensor Input
DT	Down Terminal Limit Input
DT1	Down Terminal Input 1
DT2	Down Terminal Input 2
DT3	Down Terminal Input 3
DZ	Door Zone Relay Input
EE	Electric Eye Input
EER	Electric Eye Rear Input
EMP	Emergency Power Input
EPS	Emergency Power Select Input
EQ	Earthquake Sensor Input
FB	Fire Buzzer Output
FF	Full Field Pilot Output
FL	Fire Phase I Light Output
FS	Fire Phase I On Hall Switch Input
FS2	Fire Switch Phase II On Input
FS2C	Fire Switch Phase II Call Cancel Input
FS2H	Fire Switch Phase II Hold Input
FST	Fire Stop Switch Override Output
FSTP	Fire Stop Switch Override Output
GBP	Gate Switch Bypass Input.

<u>Mnemonic</u>	<u>I/O Name</u>
GR1R	Rope Gripper 1 Relay Output.
GR2R	Rope Gripper 2 Relay Output.
GRT1	Rope Gripper Test Switch Input 1.
GRT2	Rope Gripper Test Input 2.
GS	Car Gate Switch Input
GS-1	Gate Switch Secondary Input.
GTS	Rope Gripper Trip Switch Input.
HB	Handicap Buzzer Output
HBE	DAC High Byte Enable Output
HC	Hall Call Common Input
HWS	Hoistway Smoke Sensor Input
ICI	In-Car Inspection Input.
ICR	Inconspicuous Riser Input
ID	Car top Inspection Down Input
IND	Independent Input
INS	Car Top Inspection Input
ISER	In Service Output
IU	Car Top Inspection Down Input
LBE	DAC Low Byte Enable Output
LBP	Lock Bypass Input
LC	Logic Common Input
LD	Down Hall Lantern Output
LDR	Rear Down Hall Lantern Output
LE	Level Enable Output
LE1	Level Enable 1 Output.
LE2	Level Enable 2 Output.
LED1-LED16	LED Output On A1010 Board
LOA	DAC Load Output
LU	Up Hall Lantern Output
LUR	Rear Up Hall Lantern Output
LW	Load Weighing Bypass Input
MCA	Motor Contactor Output
MCAI	Motor Contactor Input.
MES	Main Egress Smoke Detector Sensor Input
MRI	Motor Room Inspection Input.
MRID	Motor Room Inspection Down Input.
MRIU	Motor Room Inspection Up Input.
MRS	Motor Room Smoke Sensor Input
MCC	Motor Contactor Output
MCCI	Motor Contactor Input.
NB	Nudging Buzzer Output
NUD	Door Nudging Output
NUDR	Door Nudging Rear Output
OT1	OT1 Job Specific Output 1/Fire Service On Output
OT2	OT2 Job Specific Output 2/Motor Starter Timer Relay Output
OT3	OT3 Job Specific Output 3/Generator Pilot Output
OT4	OT4 Job Specific Output 4/Field Weakening Pilot Output
OVL	Overload Input

Mnemonic	I/O Name
P	Potential (Run Contactor) Input
P1-P29	1 ST – 29 th Discrete Floor Position Indicator Outputs
PFC	Primary Fault Control Output.
RDY	Drive Ready Input
RGS	Rear Car Gate Switch Input.
RGS-1	Rear Car Gate Switch Secondary Input.
RLM	Rear Lock Middle Input.
RLM-1	Rear Lock Middle Secondary Input.
RST	Reset Drive Output
RTL	Return to lobby Input
RUN	Run Pilot Output
RUNAI	Run Auxiliary Input.
RUNI	Run Input.
SC1	Speed Clamp 1 Output (Used by CPU for setup)
SC2	Speed Clamp 2 Output (Used by CPU for setup)
SC3	Speed Clamp 3 Output (Used by CPU for setup)
SC4	Speed Clamp 4 Output (Used by CPU for setup)
SC5	Speed Clamp 5 Output (Used by CPU for setup)
SE	Safety Edge Input
SER	Safety Edge Rear Input
SPI#	Spare Input, # references input number
SPO#	Spare Output, # references output number
SS	Safety String Input
SW1-SW4	Dipswitch Input From A1010 Board
TAD	Top Access Down Input.
TAU	Top Access Up Input.
TPL	Temp Low Input (Hydraulic Elevators)
UDA	Up Direction Arrow Output
UFI	Up Fast Input
UL	Up Level Sensor Input
UL-1	Up Level Sensor Secondary Input
UN	Up Normal Limit Input
UP	Up Pilot Output
UPF	Up Fast Pilot Output
UPI	Up Relay Input
UPI	Up Run Input.
US	Up Slowdown Sensor Input
UT	Up Terminal Limit Input
UT1	Up Terminal Input 1
UT2	Up Terminal Input 2
UT3	Up Terminal Input 3

I/O Locations

1038 Board	I/O LOCATIONS
Block 1	Card 1
DN	U1
DT	U1
DTS	U1
DT1	U1
DT2	U3
DT3	U3
UN	U3
UT	U3
UTS	U4
UT1	U4
UT2	U4
UT3	U4
DLB	U6
DLM	U6
DLT	U6
RLM	U6
DLB-1	U7
DLM-1	U7
DLT-1	U7
RLM-1	U7
ACC	U9
BAD	U9
BAU	U9
TAD	U9
Block 2	Card 2
TAU	U10
FSX	U10
COL	U10
EQ	U10
EQR	U12
EMH	U12
EPS	U12
EMP	U12
HWS	U13
MRS	U13
MES	U13
ALT	U13
BP	U15
FS	U15

HC	U15
SS	U15
UT4/1U	U16
UT5/2U	U16
RTL/3U	U16
Reserved/4U	U16
DT4/2D	U18
DT5/3D	U18
Spare/4D	U18
Reserved/5D	U18
Block 3	Card 3
GBP	U25
LBP	U25
IND	U25
AD	U25
DEL	U27
BKS	U27
UL-1	U27
DL-1	U27
UL	U19
DZ	U19
DL	U19
DPM	U19
GS	U21
GS-1	U21
LC	U21
INS	U21
Reserved/1UA	U66
Reserved/2UA	U67
Reserved/3UA	U68
LU/4UA	U69
Reserved/2DA	U70
Reserved/3DA	U71
Spare/4DA	U72
LD/5DA	U73
Block 4	Card 4
IU	U22
ID	U22
CS	U22
ICI	U22
MRI	U24
MRIU	U24
MRID	U24
AUTO	U24
P/RTL	U28

FST	U28
GTS	U28
RDY	U28
GRT1	U30
GRT2	U30
BRKI	U30
DON	U30
PFC	U60
MCA	U58
MCC	U59
RST	U56
Block 5	
RUNI	U31
RUNAI	U31
MCCI	U31
MCAI	U31
RGS	U33
RGS-1	U33
SECF/SVSD	U33
LVC	U33
DNI	U34/U36
DFI	U34/U36
UPI	U34/U36
UFI	U34/U36
CWS	U65
RDPM	U65
GOV	U65
PS	U65
EML	U74
EQL	U75
FSO	U78
ISER	U79
TCU/LU	U83
MST	U76
GEN/DNO	U77
FF	U57
Block 6	
RUNA	U43
RUN	U51
GR1R	U61
GR2R	U62
LE	U46
LE1	U48
FSTP	U63
FSTP1	U64

DNR	U41/U52
DF	U38/U54
UP	U40/U53
UPF	U37/U55
BRK	U44
BKC	U39
DBC	U42

1023/1041 Board		Address	Sel A	Sel B	Baud	Board ID				
		1	On	Off	Off	5	4	3	2	1
Block 7		Jumpers = CAN		U2 = 82C251		OFF	OFF	OFF	OFF	ON
1CCS	U5									
2CCS	U5									
3CCS	U5									
4CCS	U5									
5CCS	U10									
6CCS	U10									
7CCS	U10									
8CCS	U10									
9CCS	U15									
10CCS	U15									
11CCS	U15									
12CCS	U15									
13CCS	U20									
14CCS	U20									
15CCS	U20									
16CCS	U20									
17CCS	U25									
18CCS	U25									
19CCS	U25									
20CCS	U25									
21CCS	U30									
22CCS	U30									
23CCS	U30									
24CCS	U30									
Block 8										
LU	U4									
LD	U3									
LUR	U6									
LDR	U7									
UDA	U9									
DDA	U8									
FW	U11									
	U12									
	U14									

	U13
	U16
	U17
	U19
	U18
	U21
	U22
	U24
	U23
	U26
	U27
	U29
	U28
	U31
	U32

1023/1041 Board		Address	Sel A	Sel B	Baud	Board ID				
		2 On	Off	Off	5	4	3	2	1	
Block 9	Jumpers = CAN	U2 = 82C251		OFF	OFF	OFF	ON	OFF		
25CCS	U5									
26CCS	U5									
27CCS	U5									
28CCS	U5									
29CCS	U10									
SECUR	U10									
	U10									
	U10									
	U15									
	U15									
	U15									
25RCS	U15									
26RCS	U20									
27RCS	U20									
28RCS	U20									
29RCS	U20									
	U25									
	U25									
	U25									
	U25									
	U30									
	U30									
	U30									
	U30									
Block 10										
	U4									
	U3									

	U6
	U7
	U9
	U8
	U11
	U12
	U14
	U13
	U16
	U17
	U19
	U18
	U21
	U22
	U24
	U23
	U26
	U27
	U29
	U28
	U31
	U32

1023/1041 Board		Address	Sel A	Sel B	Baud	Board ID				
		3	On	Off	Off	5	4	3	2	1
Block 11	Jumpers = CAN			U2 = 82C251		OFF	OFF	OFF	ON	ON
1RCS	U5									
2RCS	U5									
3RCS	U5									
4RCS	U5									
5RCS	U10									
6RCS	U10									
7RCS	U10									
8RCS	U10									
9RCS	U15									
10RCS	U15									
11RCS	U15									
12RCS	U15									
13RCS	U20									
14RCS	U20									
15RCS	U20									
16RCS	U20									
17RCS	U25									
18RCS	U25									
19RCS	U25									
20RCS	U25									

21RCS	U30
22RCS	U30
23RCS	U30
24RCS	U30
Block 12	
	U4
	U3
	U6
	U7
	U9
	U8
	U11
	U12
	U14
	U13
	U16
	U17
	U19
	U18
	U21
	U22
	U24
	U23
	U26
	U27
	U29
	U28
	U31
	U32

1023/1041									
Board	Address	Sel A	Sel B	Baud	Board ID				
		5 On	Off	Off	5	4	3	2	1
Block 15	Jumpers = CAN	U2 = 82C251		OFF	OFF	ON	OFF	ON	
13C	U5								
14C	U5								
15C	U5								
16C	U5								
17C	U10								
18C	U10								
19C	U10								
20C	U10								
21C	U15								
22C	U15								
23C	U15								
24C	U14								

25C	U20
26C	U20
27C	U20
28C	U20
29C	U25
	U25
	U25
	U25
	U30
	U30
	U30
	U30
Block 16	
13CA	U4
14CA	U3
15CA	U6
16CA	U7
17CA	U9
18CA	U8
19CA	U11
20CA	U12
21CA	U14
22CA	U13
23CA	U16
24CA	U17
25CA	U19
26CA	U18
27CA	U21
28CA	U22
29CA	U24
	U23
	U26
	U27
	U29
	U28
	U31
	U32

1023/1041									
Board									
	Address	Sel A	Sel B	Baud	Board ID				
		4 On	Off	Off	5	4	3	2	1
Block 13	Jumpers = CAN		U2 = 82C251		OFF	OFF	ON	OFF	OFF
1C	U5								
2C	U5								
3C	U5								

4C	U5
5C	U10
6C	U10
7C	U10
8C	U10
9C	U15
10C	U15
11C	U15
12C	U14
FS2	U20
FS2H	U20
FS2C	U20
HBE	U20
DCB	U25
DOB	U25
INDC	U25
EMS	U25
ATT	U30
ATTUP	U30
ATTDN	U30
ATTBP	U30
Block 14	
1CA	U4
2CA	U3
3CA	U6
4CA	U7
5CA	U9
6CA	U8
7CA	U11
8CA	U12
9CA	U14
10CA	U13
11CA	U16
12CA	U17
FL	U19
FB/NB	U18
HB/CDL	U21
CUL	U22
CDL/HB	U24
DDA	U23
P1/EDL	U26
P2	U27
P3	U29
P4	U28
P5	U31
UDA	U32

1023/1041 Board		Address	Sel A	Sel B	Baud	Board ID				
		6On	Off	Off	5	4	3	2	1	
Block 17	Jumpers = CAN	U2 = 82C251	OFF	OFF	ON	ON	ON	ON	OFF	
1CR	U5									
2CR	U5									
3CR	U5									
4CR	U5									
5CR	U10									
6CR	U10									
7CR	U10									
8CR	U10									
9CR	U15									
10CR	U15									
11CR	U15									
12CR	U14									
13CR	U20									
14CR	U20									
15CR	U20									
16CR	U20									
17CR	U25									
DOLR	U25									
DCLR	U25									
	U25									
EER	U30									
SER	U30									
DCBR	U30									
DOBR	U30									
Block 18										
1CAR	U4									
2CAR	U3									
3CAR	U6									
4CAR	U7									
5CAR	U9									
6CAR	U8									
7CAR	U11									
8CAR	U12									
9CAR	U14									
10CAR	U13									
11CAR	U16									
12CAR	U17									
13CAR	U19									

14CAR	U18
15CAR	U21
16CAR	U22
17CAR	U24
CDLR	U23
CULR	U26
	U27
	U29
DOR	U28
DCR	U31
NUDR	U32

1023/1041 Board		Address	Sel A	Sel B	Baud	Board ID				
			7 On	Off	Off	5	4	3	2	1
Block 19	Jumpers = CAN			U2 = 82C251	OFF	OFF	ON	ON	ON	ON
18CR	U5									
19CR	U5									
20CR	U5									
21CR	U5									
22CR	U10									
23CR	U10									
24CR	U10									
25CR	U10									
26CR	U15									
27CR	U15									
28CR	U15									
29CR	U15									
	U20									
	U20									
	U20									
	U20									
	U25									
	U25									
	U25									
	U25									
	U30									
	U30									
	U30									
	U30									
Block 20										
18CAR	U4									
19CAR	U3									
20CAR	U6									
21CAR	U7									
22CAR	U9									
23CAR	U8									

24CAR	U11
25CAR	U12
26CAR	U14
27CAR	U13
28CAR	U16
29CAR	U17
	U19
	U18
	U21
	U22
	U24
	U23
	U26
	U27
	U29
	U28
	U31
	U32

1037 Board	Address
	9
Block 23	
1C	U28
2C	U28
3C	U28
4C	U28
5C	U34
6C	U34
7C	U34
8C	U34
9C	U39
10C	U39
11C	U39
12C	U39
FS2	U45
FS2H	U45
FS2C	U45
HBE	U45
DCB	U50
DOB	U50
INDC	U50
EMS	U50
ATT	U49
ATTUP	U49
ATTDN	U49
ATTBP	U49
Block 24	

1CA	U26
2CA	U27
3CA	U29
4CA	U30
5CA	U32
6CA	U33
7CA	U35
8CA	U36
9CA	U37
10CA	U38
11CA	U40
12CA	U41
DDA	U21
P1/EDL	U22
P2	U24
P3	U25
P4	U43
P5	U44
P6	U46
UDA	U47
EQL	U15
EML	U16
OLL	U18
CLF	U19
Block 25	
DOL	U17
DCL	U17
EE	U17
SE	U17
LWA	U23
OVL	U23
LWB	U23
LWD	U23
BP1	U6
BP2	U6
BP4	U6
BP8	U6
BP16	U12
EP	U12
US	U12
DS	U12
DO	U4
DC	U5
NUD	U7
CUL	U8
CDL	U10
FL	U11
FB/NB	U13

HB	U14
----	-----

1040 Board	Address
Block 25	9
DOL	U17
DCL	U17
EE	U17
SE	U17
LWA	U23
OVL	U23
LWB	U23
LWD	U23
BP1	U6
BP2	U6
BP4	U6
BP8	U6
BP16	U12
EP	U12
US	U12
DS	U12
DO	U4
DC	U5
NUD	U7
P6	U8
EQL	U10
EML	U11
OLL	U13
CLF	U14