



Hollister-Whitney Elevator Corporation

#1 Hollister-Whitney Parkway
Quincy, IL 62305
Phone: 217-222-0466

Fax: 217-222-0493
e-mail: info@hollisterwhitney.com
www.hollisterwhitney.com

BULLETIN # 1164 SETTING ROPE GRIPPER® TRIGGER RELEASE PRESSURE AND CONFIRMING ELECTRICAL CONNECTIONS

Tools Required:

5/32" Allen Wrench
3/8" Open End Wrench
Flathead Screwdriver
30 pound (minimum) Door Pressure Scale
Small Metal Point File

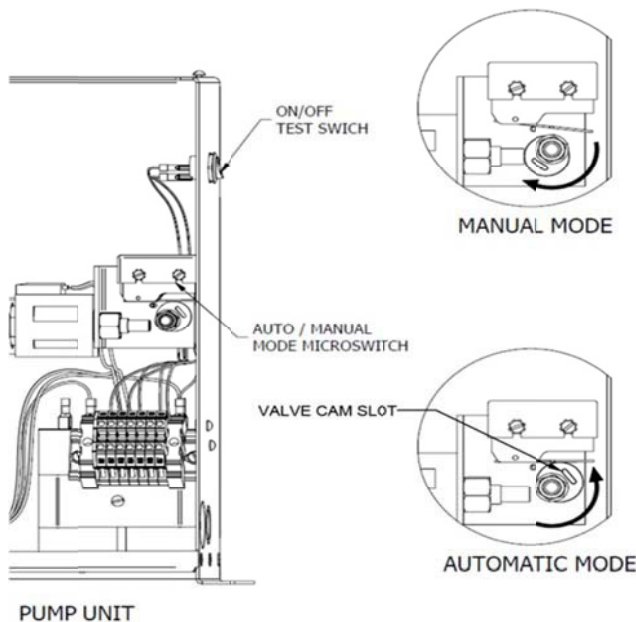

Figure 1

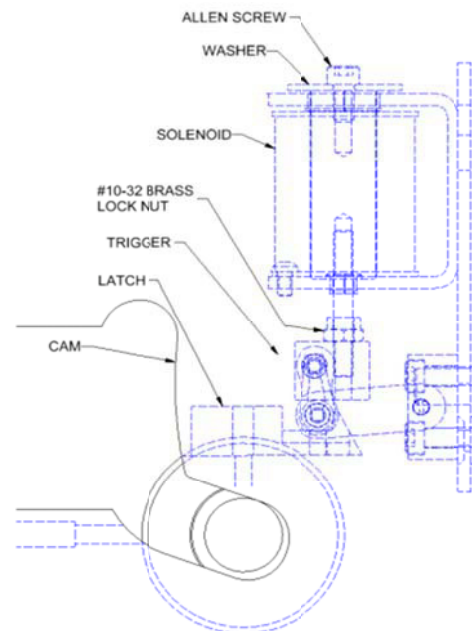

Figure 2

Caution: Keep fingers and hands clear of Rope Gripper®, forces created can crush fingers.

1. Refer to Figures 1 and 2 for location of Rope Gripper® parts. Place Elevator on Inspection and turn off test switch on side of Pumping Unit.
2. Check for burrs on the edges of the latch and file with small point file if necessary (see Figure 3).
3. Turn the Rope Gripper® test switch to “ON” so that the Gripper® opens fully (reloads) and is not touching the hoist cables.
4. With a flat head screwdriver placed in the valve cam slot, turn the cam clockwise to fully close the valve (Manual mode, see Figure 4).

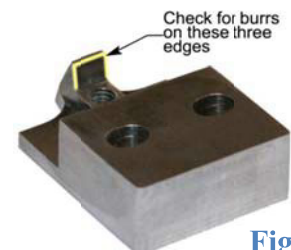

Figure 3

5. To adjust the valve to the slowest possible pressure relief (drop-out) speed, turn the Gripper[®] power switch “OFF” and slightly turn the valve cam counterclockwise until the trigger unit moves slowly past the latch to the clamped (on hoist ropes) position. Turn the power switch “ON” and repeat this procedure to get the slowest possible drop-out speed.
6. When slow drop-out speed is achieved, turn power switch “ON”. With Rope Gripper[®] energized, apply Pressure Scale to Allen Screw on top of trigger solenoid with 25 pounds of force (See Figure 5). Turn power switch “OFF” while holding the 25 pounds of force.
7. Slowly reduce the pressure from 25 pounds and observe the pressure at the point where the trigger assembly releases. Note this pressure. The correct release pressure should be from 15 to 17 pounds.
8. If pressure is not correct, loosen (turn counterclockwise) the #10-32 brass locking nut on bottom of solenoid armature (see Figure 6) with a 3/8” open end wrench. Adjust the Allen screw on top of solenoid clockwise to increase or counterclockwise to decrease the Gripper[®] Release pressure. Adjust by turning Allen screw ½ turn at a time (see Figure 7).
9. Tighten the #10-32 brass locking nut (**Caution: Do not over tighten as it may strip threads**) and repeat steps 5 thru 8 as needed, until correct release pressure of 15 to 17 pounds is obtained.
10. Turn the power switch “ON” and turn the valve cam counterclockwise to actuate the “Auto/Manual Mode Micro switch” in the auto position (Automatic Mode, see Figure 1).
11. Turn power switch “OFF” to activate Gripper[®]. Gripper[®] should clamp hoist ropes. Turn Gripper[®] power switch “ON”. Gripper[®] should reload to the ready position. Return Elevator to Service.



Figure 4



Figure 5



Figure 6



Figure 7



Hollister-Whitney Elevator Corporation

#1 Hollister-Whitney Parkway
Quincy, IL 62305
Phone: 217-222-0466

Fax: 217-222-0493
e-mail: info@hollisterwhitney.com
www.hollisterwhitney.com

MICRO SWITCH LOCATION VERIFICATION

While the operation of the Elevator Can Run and the Brake Ready micro switch may still work properly, the screw for the Brake Ready micro switch should be adjustable and the screw for the Elevator Can Run micro switch is not. The micro switches may be in either position.

Follow this procedure to find the position of the Brake Ready micro switch and move the screws if necessary.

Always keep hands and fingers clear when working on the Gripper[®].
The car should be stationary, perhaps on inspection operation.

1. Turn off Pump Unit Test Switch.
2. Use screwdriver, activate either micro switch and keep activated (see Figure 8).
3. Turn pump unit switch on and then off. If pump didn't turn on, you activated the Brake Ready Micro. This assumes that the pump would turn on immediately if you didn't activate the micro switch.
4. If the pump turned on, repeat steps 1-3 and activate opposite micro.
5. If necessary remove angle and then move adjustable screw to Brake Ready micro switch and other screw as shown to Elevator Can Run micro switch. Reinstall angle.
6. Adjust the Brake Ready micro switch so that pump turns off after trigger latch engages.

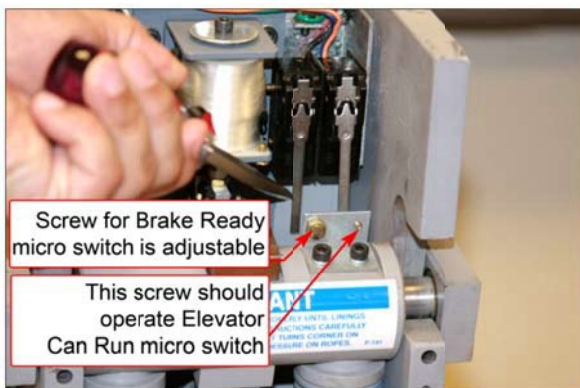

Figure 8



Hollister-Whitney Elevator Corporation

#1 Hollister-Whitney Parkway
Quincy, IL 62305
Phone: 217-222-0466

Fax: 217-222-0493
e-mail: info@hollisterwhitney.com
www.hollisterwhitney.com

ELECTRICAL CONNECTION VERIFICATION

The wiring of the controls to the pump unit should be as per the control manufacturers' diagrams, with wires from the control to terminals RG1, RG2, RG5, RG7 and ground terminal EGND. Wires from the Gripper® to the pump unit are color coded and should be checked and correctly wired as:

- White – RG2
- Black – RG3
- Red – RG4
- Orange – RG5
- Blue – RG6
- Green – EGND

ROPE GRIPPER® ELECTRICAL SCHEMATIC

